

# ***Rockchip RK3326 Datasheet***

**Revision 1.1  
April. 2018**

## **Revision History**

<b>Date</b>	<b>Revision</b>	<b>Description</b>
2018-4-11	1.1	Update description
2018-02-27	1.0	Initial released

Rockchip Confidential

## **Table of Content**

Table of Content .....	3
Figure Index .....	4
Table Index.....	5
Warranty Disclaimer.....	6
Chapter 1 Introduction .....	7
1.1 Overview .....	7
1.2 Features .....	7
1.3 Block Diagram .....	17
Chapter 2 Package Information.....	18
2.1 Order Information .....	18
2.2 Top Marking .....	18
2.3 TFBGA395LDimension .....	18
2.4 Ball Map .....	20
2.5 Pin Number List .....	25
2.6 Power/Ground IO Description .....	31
2.7 Function IO Description.....	33
2.8 IO Pin Name Description .....	42
Chapter 3 Electrical Specification .....	47
3.1 Absolute Ratings .....	47
3.2 Recommended Operating Condition .....	47
3.3 DC Characteristics.....	48
3.4 Electrical Characteristics for General IO .....	49
3.5 Electrical Characteristics for PLL .....	50
3.6 Electrical Characteristics for USB 2.0 Interface .....	51
3.7 Electrical Characteristics for DDR IO.....	51
3.8 Electrical Characteristics for TSADC.....	52
3.9 Electrical Characteristics for MIPI DSI.....	52
3.10 Electrical Characteristics for MIPI CSI .....	53
Chapter 4 Thermal Management.....	54
4.1 Overview .....	54
4.2 Package Thermal Characteristics .....	54

## **Figure Index**

Fig.1-1 Block Diagram.....	17
Fig.2-1Package definition.....	18
Fig.2-2Package Top View .....	18
Fig.2-3Package bottom view.....	19
Fig.2-4Package side view.....	19
Fig.2-5Package dimension.....	20
Fig.2-6Ball Map-1 .....	21
Fig.2-7Ball Map-2 .....	22
Fig.2-8Ball Map-3 .....	23
Fig.2-9Ball Map-4 .....	24

Rockchip Confidential

## Table Index

Table 2-1 Pin NumberList Information.....	25
Table 2-2 Power/Ground IO information .....	31
Table 2-3 Function IO description .....	33
Table 2-4 IO function description list .....	42
Table 3-1 Absolute ratings.....	47
Table 3-2 Recommended operating condition .....	47
Table 3-3 DC Characteristics.....	48
Table 3-4 Electrical Characteristics for Digital General IO .....	49
Table 3-5 Electrical Characteristics for PLL.....	50
Table 3-6 Electrical Characteristics for USB 2.0 Interface .....	51
Table 3-7 Electrical Characteristics for DDR IO .....	51
Table 3-8 Electrical Characteristics for TSADC .....	52
Table 3-9 Electrical Characteristics for MIPI DSI .....	52
Table 3-10 Electrical Characteristics for MIPI CSI.....	53
Table 4-1 Thermal Resistance Characteristics.....	54

## Warranty Disclaimer

Rockchip Electronics Co., Ltd makes no warranty, representation or guarantee (expressed, implied, statutory, or otherwise) by or with respect to anything in this document, and shall not be liable for any implied warranties of non-infringement, merchantability or fitness for a particular purpose or for any indirect, special or consequential damages.

Information furnished is believed to be accurate and reliable. However, Rockchip Electronics Co., Ltd assumes no responsibility for the consequences of use of such information or for any infringement of patents or other rights of third parties that may result from its use.

Rockchip Electronics Co., Ltd's products are not designed, intended, or authorized for using as components in systems intended for surgical implant into the body, or other applications intended to support or sustain life, or for any other application in which the failure of the Rockchip Electronics Co., Ltd's product could create a situation where personal injury or death may occur, should buyer purchase or use Rockchip Electronics Co., Ltd's products for any such unintended or unauthorized application, buyers shall indemnify and hold Rockchip Electronics Co., Ltd and its officers, employees, subsidiaries, affiliates, and distributors harmless against all claims, costs, damages, expenses, and reasonable attorney fees arising out of, either directly or indirectly, any claim of personal injury or death that may be associated with such unintended or unauthorized use, even if such claim alleges that Rockchip Electronics Co., Ltd was negligent regarding the design or manufacture of the part.

## Copyright and Patent Right

Information in this document is provided solely to enable system and software implementers to use Rockchip Electronics Co., Ltd 's products. There are no expressed or implied copyright licenses granted hereunder to design or fabricate any integrated circuits or integrated circuits based on the information in this document.

**Rockchip Electronics Co., Ltd does not convey any license under its patent rights nor the rights of others.**

**All copyright and patent rights referenced in this document belong to their respective owners and shall be subject to corresponding copyright and patent licensing requirements.**

## Trademarks

Rockchip and Rockchip™ logo and the name of Rockchip Electronics Co., Ltd's products are trademarks of Rockchip Electronics Co., Ltd. and are exclusively owned by Rockchip Electronics Co., Ltd. References to other companies and their products use trademarks owned by the respective companies and are for reference purpose only.

## Confidentiality

The information contained herein (including any attachments) is confidential. The recipient hereby acknowledges the confidentiality of this document, and except for the specific purpose, this document shall not be disclosed to any third party.

**Reverse engineering or disassembly is prohibited.**

**ROCKCHIP ELECTRONICS CO.,LTD. RESERVES THE RIGHT TO MAKE CHANGES IN ITS PRODUCTS OR PRODUCT SPECIFICATIONS WITH THE INTENT TO IMPROVE FUNCTION OR DESIGN AT ANY TIME AND WITHOUT NOTICE AND IS NOT REQUIRED TO UNDATE THIS DOCUMENTATION TO REFLECT SUCH CHANGES.**

## Copyright © 2018 Rockchip Electronics Co., Ltd.

All rights reserved. No part of this publication may be reproduced, stored in a retrieval system, or transmitted in any form or by any means, electric or mechanical, by photocopying, recording, or otherwise, without the prior written consent of Rockchip Electronics Co., Ltd.

## Chapter 1 Introduction

### 1.1 Overview

RK3326 is a high-performance Quad-core application processor designed for personal tablet and smart audio device.

Many embedded powerful hardware engines are provided to optimize performance for high-end application. RK3326 supports almost full-format H.264 decoder by 1080p@60fps, H.265 decoder by 1080p@60fps, also support H.264 encoder by 1080p@30fps, high-quality JPEG encoder/decoder.

Embedded 3D GPU makes RK3326 completely compatible with OpenGL ES 1.1/2.0/3.2, DirectX 11 FL9\_3, OpenCL 2.0 and Vulkan 1.0. Special 2D hardware engine will maximize display performance and provide very smoothly operation.

RK3326 has high-performance external memory interface(DDR3/DDR3L/DDR4 /LPDDR2/LPDDR3) capable of sustaining demanding memory bandwidths.

### 1.2 Features

The features listed below which may or may not be present in actual product, may be subject to the third party licensing requirements. Please contact Rockchip for actual product feature configurations and licensing requirements.

#### 1.2.1 Microprocessor

- Quad-core ARM Cortex-A35 CPU
- Full implementation of the ARM architecture v8-A instruction set
- ARM Neon Advanced SIMD (single instruction, multiple data) support for accelerated media and signal processing computation
- ARMv8 Cryptography Extensions
- In-order pipeline with symmetric dual-issue of most instructions
- 256KB unified system L2 cache
- Include VFP v3 hardware to support single and double-precision operations
- Integrated 32KB L1 instruction cache, 32KB L1 data cache with 4-way set associative
- TrustZone technology support
- Separate power domains for CPU core system to support internal power switch and externally turn on/off based on different application scenario
  - PD\_A35\_0: 1st Cortex-A35 + Neon + FPU + L1 I/D Cache
  - PD\_A35\_1: 2nd Cortex-A35 + Neon + FPU + L1 I/D Cache
  - PD\_A35\_2: 3rd Cortex-A35 + Neon + FPU + L1 I/D Cache
  - PD\_A35\_3: 4th Cortex-A35 + Neon + FPU + L1 I/D Cache
- One isolated voltage domain to support DVFS

#### 1.2.2 Memory Organization

- Internal on-chip memory
  - BootROM
  - SYSTEM\_SRAM in the voltage domain of VD\_LOGIC
  - PMU\_SRAM in the voltage domain of VD\_PMU for low power application
- External off-chip memory<sup>①</sup>
  - DDR3/DDR3L/DDR4/LPDDR2/LPDDR3
  - SPI Flash
  - eMMC
  - SD\_Card
  - 8bits Async Nand Flash

- 8bits toggle Nand Flash
- 8bit ONFI Nand Flash

### 1.2.3 Internal Memory

- Internal BootRom
  - Support system boot from the following device:
    - ◆ SPI Flash interface
    - ◆ eMMC interface
    - ◆ SDMMC interface
    - ◆ Toggle Nand Flash
    - ◆ Async Nand FLash
  - Support system code download by the following interface:
    - ◆ USB OTG interface (Device mode)
- SYSTEM\_SRAM
  - Size: 16KB
- PMU\_SRAM
  - Size: 8KB

### 1.2.4 External Memory or Storage device

- Dynamic Memory Interface (DDR3/DDR3L/DDR4/LPDDR2/LPDDR3)
  - Compatible with JEDEC standards
  - Compatible with DDR3-1600/DDR3L-1600/DDR4-1600/LPDDR2-1066 /LPDDR3-1600
  - Support 32-bit data width, 2 ranks (chip selects), max 4GB addressing space per rank; total addressing space is 4GB(max) also
  - Low power modes, such as power-down and self-refresh for SDRAM
  - Compensation for board delays and variable latencies through programmable pipelines
  - Programmable output and ODT impedance with dynamic PVT compensation
- eMMC Interface
  - Compatible with standard iNAND interface
  - Support eMMC ver4.51, compatible with 4.41, 5.0 and 5.1
  - Support three data bus width: 1-bit, 4-bit or 8-bit
  - Support up to HS200, but not support CMD Queue
- SD/MMC Interface
  - Compatible with SD3.0, MMC ver4.51
  - Data bus width is 4bits
- Nand Flash Interface
  - Support async nand flash, each channel 8bits, up to 4 banks
  - Support ONFI Synchronous Flash Interface, each channel 8bits, up to 4 banks
  - Support Toggle Flash Interface, each channel 8bits, up to 4 banks
  - Support LBA nand flash in async or sync mode
  - Up to 70bits/1KB hardware ECC
  - For DDR nand flash, support DLL bypass and 1/4 or 1/8 clock adjust, maximum clock rate is 75MHz
  - For async nand flash, support configurable interface timing , maximum data rate is 8bit/cycle

### 1.2.5 System Component

- CRU (clock & reset unit)
  - Support clock gating control for individual components



- One oscillator with 24MHz clock input
- Support global soft-reset control for whole chip, also individual soft-reset for each component
- PMU(power management unit)
  - 3 separate voltage domains(VD\_CORE/VD\_LOGIC/VD\_PMU)
  - 14 separate power domains, which can be power up/down by software based on different application scenes
  - Multiple configurable work modes to save power by different frequency or automatic clock gating control or power domain on/off control
- Timer
  - Six 64bits timers with interrupt-based operation for non-secure application
  - Two 64bits timers with interrupt-based operation for secure application
  - Support two operation modes: free-running and user-defined count
  - Support timer work state checkable
- PWM
  - Two on-chip PWMs with interrupt-based operation
  - Programmable pre-scaled operation to bus clock and then further scaled
  - Embedded 32-bit timer/counter facility
  - Support capture mode
  - Support continuous mode or one-shot mode
  - Provides reference mode and output various duty-cycle waveform
- Watchdog
  - 32-bit watchdog counter
  - Counter counts down from a preset value to 0 to indicate the occurrence of a timeout
  - WDT can perform two types of operations when timeout occurs:
    - ◆ Generate a system reset
    - ◆ First generate an interrupt and if this is not cleared by the service routine by the time a second timeout occurs then generate a system reset
  - Programmable reset pulse length
  - Totally 16 defined-ranges of main timeout period
  - One Watchdog for non-secure application
  - One Watchdog for secure application
- Interrupt Controller
  - Support 3 PPI interrupt source and 128 SPI interrupt sources input from different components
  - Support 16 software-triggered interrupts
  - Two interrupt outputs (nFIQ and nIRQ) separately for each Cortex-A35, both are low-level sensitive
  - Support different interrupt priority for each interrupt source, and they are always software-programmable
- DMAC
  - Micro-code programming based DMA
  - The specific instruction set provides flexibility for programming DMA transfers
  - Linked list DMA function is supported to complete scatter-gather transfer
  - Support internal instruction cache
  - Embedded DMA manager thread
  - Support data transfer types with memory-to-memory, memory-to-peripheral, peripheral-to-memory
  - Signals the occurrence of various DMA events using the interrupt output signals
  - Mapping relationship between each channel and different interrupt outputs is

- software-programmable
  - One embedded DMA controller for system
  - DMAC features:
    - ◆ 8 channels totally
    - ◆ 23 hardware request from peripherals
    - ◆ 2 interrupt output
    - ◆ Dual APB slave interface for register configuration, designated as secure and non-secure
    - ◆ Support trustzone technology and programmable secure state for each DMA channel
- Secure system
  - TrustZone based Trusted Execution Environment (TEE) for the following components
    - ◆ Cortex-A35, support security and non-security mode, switch by software
    - ◆ System general DMAC, support some dedicated channels work only in security mode
    - ◆ Secure OTP, only can be accessed by Cortex-A35 in secure mode and secure key reader block
    - ◆ SYSTEM\_SRAM, part of space is addressed only in security mode, detailed size is software-programmable together with TZMA (TrustZone memory adapter)
    - ◆ eight secure address space in DDR device, the start address and end address for each address scope is configurable, maximum 4GB secure address are supported
  - Cipher engine
    - ◆ Support SHA-1, SHA-256/224, SHA-512/384, MD5 with hardware padding
    - ◆ Support HMAC of SHA-1, SHA-256, SHA-512, MD5 with hardware padding
    - ◆ Support AES-128, AES-192, AES-256 encrypt & decrypt cipher
    - ◆ Support DES & TDES cipher
    - ◆ Support AES ECB/CBC/OFB/CFB/CTR/CTS/XTS/CCM/GCM/CBC-MAC/CMAC mode
    - ◆ Support DES/TDES ECB/CBC/OFB/CFB mode
    - ◆ Support up to 4096 bits PKA mathematical operations for RSA/ECC
    - ◆ Support hardware key loader from secure OTP, which is not accessible by other devices, including Cort4ex-A35
  - Support data scrambling for DDR3/DDR3L/DDR4/LPDDR2/LPDDR3
  - Support up to 256 bits TRNG Output
  - Support secure OTP
  - Support secure boot
  - Support secure debug

### 1.2.6 Video CODEC

- Video Decoder
  - Real-time decoding of MPEG-4, H.264, H.265/HEVC, VP8, VC-1
  - H.264/AVC Base/Main/High@level4.2; up to 1080P@60fps
  - H.265/HEVC Main10 profile@level4.2; up to 1080P@60fps
  - VP8, up to 1080P@60fps
  - MPEG-4, ISO/IEC 14496-2, SP@L0-3, ASP@L0-5, up to 1080P@60fps
  - VC-1, SP@ML, MP@HL, AP@L0-3, up to 1080P@60fps
  - MVC is supported based on H.264 or H.265, up to 1080P@60fps
- Video Encoder
  - Support H.264 video encoder at BP/MP/HP@level4.2
  - Resolution and frame rate are up to 1920x1080@30FPS
  - 1x1080p@30fps or 2x720p@30fps encoding

### 1.2.7 JPEG CODEC

- JPEG decoder
  - Decoder size is from 48x48 to 8176x8176(66.8Mpixels)
  - Support JPEG ROI (region of image) decode

### 1.2.8 Graphics Engine

- 3D Graphics Engine:
  - Support DirectX 11 FL9\_3
  - Support OpenGL ES 1.1, 2.0, and 3.2
  - Support Vulkan 1.0
  - Support OpenCL 2.0 Full Profile
- 2D Graphics Engine:
  - Data format
    - ◆ Support input of ARGB/RGB888/RGB565/RGB4444/RGB5551/YUV420/YUV422
    - ◆ Support input of YUV422SP10bit/YUV420SP10bit(YUV-8bits out)
    - ◆ Support output of ARGB/RGB888/RGB565/RGB4444/RGB5551/YUV420/YUV422
    - ◆ Pixel Format conversion, BT.601/BT.709
    - ◆ Dither operation
    - ◆ Max resolution: 8192x8192 source, 4096x4096 destination
  - Scaling
    - ◆ Down-scaling: Average filter
    - ◆ Up-scaling: Bi-cubic filter(source>2048 would use Bi-linear)
    - ◆ Arbitrary non-integer scaling ratio, from 1/8 to 8
  - Rotation
    - ◆ 0, 90, 180, 270 degree rotation
    - ◆ x-mirror, y-mirror& rotation operation
  - BitBLT
    - ◆ Block transfer
    - ◆ Color palette/Color fill, support with alpha
    - ◆ Transparency mode (color keying/stencil test, specified value/value range)
    - ◆ Two source BitBLT:
      - ◆ A+B=B only BitBLT, A support rotate&scale when B fixed
      - ◆ A+B=C second source (B) has same attribute with (C) plus rotation function
  - Alpha Blending
    - ◆ New comprehensive per-pixel alpha(color/alpha channel separately)
    - ◆ Fading
    - ◆ SRC1(R2Y)&&SRC0(YUV)—alpha->DST(YUV)

### 1.2.9 Video input interface

- Interface and video input processor
  - Support up to 12bit DPI interface (digital parallel input)
  - Support up MIPI CSI RX interface
  - Support VIP block(Video Input Processor)
  - Support ISP block(Image Signal Processor)
  - Support DPI interface to VIP block
  - Support DPI interface to ISP block
  - Support MIPI CSI RX interface to ISP block
  - Support the following two mode simultaneously
    - ◆ DPI interface with VIP
    - ◆ MIPI CSI RX interface with ISP
- DPI Interface
  - Support 8bit input
  - Support up to 150MHz input data

- MIPI CSI RX Interface
  - Compatible with the MIPI Alliance Interface specification v1.0
  - Up to 4 data lane, 1.0Gbps maximum data rate per lane
  - Support MIPI-HS, MIPI-LP mode
- VIP
  - Support YCbCr422 8bit input
  - Support Raw 8bit/10bit/12bit input
  - Support CCIR656(PAL/NTSC) input
  - Support JPEG input
  - Support YCbCr422/420 output
  - Support UYVY/VYUY/YUYV/YVYU configurable
  - Support up to 8192x8192 resolution source
  - Support picture in picture
  - Support arbitrary size window crop
- ISP
  - Generic Sensor Interface with programmable polarity for synchronization signals
  - ITU-R BT 601/656 compliant video interface supporting YCbCr or RGB Bayer data
  - 12 bit camera interface
  - 12 bit resolution per color component internally
  - YCbCr 4:2:2 processing
  - Flash light control
  - Mechanical shutter support
  - Windowing and frame synchronization
  - Frame skip support for video (e.g. MPEG-4) encoding
  - Macro block line, frame end, capture error, data loss interrupts and sync. (h\_start, v\_start) interrupts
  - Luminance/chrominance and chrominance blue/red swapping for YUV input signals
  - Continuous resize support
  - Semi planar storage format
  - Color processing (contrast, saturation, brightness, hue, offset, range)
  - Power management by software controlled clock disabling of currently not needed sub-modules
  - Four channel Lens shade correction (Vignetting)
  - Auto focus measurement
  - White balancing and black level measurement
  - Auto exposure support by brightness measurement in 5x5 sub windows
  - Defect pixel cluster correction unit (DPCC) supports on the fly and table based pixel correction
  - De-noising pre filter (DPF)
  - Enhanced color interpolation (RGB Bayer demosaicing)
  - Chromatic aberration correction
  - Combined edge sensitive Sharpening / Blurring filter (Noise filter)
  - Color correction matrix (cross talk matrix)
  - Global Tone Mapping with wide dynamic range unit (WDR)
  - Image Stabilization support and Video Stabilization Measurement
  - Flexible Histogram calculation
  - Digital image effects (Emboss, Sketch, Sepia, B/W (Grayscale), Color Selection, Negative image, sharpening)
  - Solarize effect through gamma correction
  - Maximum input resolution of 3264x2448 pixels
  - Main scaler with pixel-accurate up- and down-scaling to any resolution between 3264x2448 and 32x16 pixel in processing mode
  - Self scaler with pixel-accurate up- and down-scaling to any resolution between 1920x1080 and 32x16 pixel in processing mode

- Support of semiplanar NV21 color storage format
- Support of image cropping
- Support Y12BIT and UV 8BIT path output after GAMMAOUT module
- Support RGB output after GAMMAOUT module
- Support hurry for latency FIFO
- Support Two-in-one RK-Tone-Mapping with wide dynamic range unit (Block/Global WDR)
- Support Video Stabilization Measurement (VSM) Programming update to 3264x2448

### 1.2.10 Display interface

- Display interface
  - Support RGB Parallel Display interface
  - Support MIPI\_DSI interface
  - Support LVDS interface
  - Support Parallel Display interface and MIPI\_DSI display simultaneously
  - Support Parallel Display interface and LVDS display simultaneously
  - Support different or identical source for dual display interface
- RGB Parallel Display interface
  - Up to 1080p@60fps display output
  - Up to 24bit output data
- MIPI\_DSI interface
  - Compatible with MIPI Alliance Interface specification v1.0
  - Support 4 data lane, 1.0Gbps maximum data rate per lane
  - Up to 1080p@60fps display output
  - Support HS and LP mode
- LVDS interface
  - Compliant with the TIA/EIA-644-A LVDS specification
  - Compliant with LVTTTL IO, support direct RGB data output
  - Support RGB888 and RGB666 for LVDS interface
  - Support VESA/JEIDA LVDS data format transfer
  - Up to 1280x800@60fps

### 1.2.11 Video Output Processor

- Display interface
  - Parallel RGB LCD Interface: 24-bit(RGB888),18-bit(RGB666), 16-bit(RGB565)
  - Max output resolution
    - ◆ Up to 1920x1080 with CABC disable
    - ◆ Up to 1280x800 with CABC enable
- Display process
  - Background layer
    - ◆ programmable 24-bit color
  - Win0 layer
    - ◆ Input format : RGB888, ARGB888, RGB565, YCbCr422, YCbCr420, YCbCr444
    - ◆ 1/8 to 8 scaling-down and scaling-up engine
    - ◆ Support virtual display
    - ◆ 256 level alpha blending (pre-multiplied alpha support)
    - ◆ Transparency color key
    - ◆ YCbCr2RGB(rec601-mpeg/ rec601-jpeg/rec709)
    - ◆ RGB2YCbCr(BT601/BT709)
  - Win1 layer
    - ◆ Input format : RGB888, ARGB888, RGB565
    - ◆ Support virtual display

- ◆ 256 level alpha blending (pre-multiplied alpha support)
- ◆ Transparency color key
- ◆ RGB2YCbCr(BT601/BT709)
- ◆ Support frame buffer data decompression
- HWC layer
  - ◆ Support 8BPP only
  - ◆ Size : 32x32 or 64x64
  - ◆ 256 level alpha blending (pre-multiplied alpha support)
  - ◆ RGB2YCbCr(BT601/BT709)
- Others
  - Win0 layer , Win1 layer overlay exchangeable
  - Support RGB or YUV domain overlay
  - BCSH(Brightness, Contrast, Saturation, Hue adjustment)
  - BCSH:YCbCr2RGB(rec601-mpeg/ rec601-jpeg/rec709)
  - BCSH:RGB2YCbCr(BT601/BT709)
  - Support Gamma adjust
  - Support CABG (Content Adaptive Backlight Control)
  - Support dither down allegro RGB888to666 RGB888to565 & dither down frc (configurable ) RGB888to666
  - Blank and black display
  - Standby mode

### 1.2.12 Audio Interface

- I2S0 with 8 channel
  - Up to 8 channels TX and 8 channels RX path
  - Audio resolution from 16bits to 32bits
  - Sample rate up to 192KHz
  - Provides master and slave work mode, software configurable
  - Support 3 I2S formats (normal, left-justified, right-justified)
  - Support 4 PCM formats (early, late1, late2, late3)
  - I2S and PCM mode cannot be used at the same time
- I2S1/I2S2 with 2 channel
  - Up to 2 channels for TX and 2 channels RX path
  - Audio resolution from 16bits to 32bits
  - Sample rate up to 192KHz
  - Provides master and slave work mode, software configurable
  - Support 3 I2S formats (normal, left-justified, right-justified)
  - Support 4 PCM formats (early, late1, late2, late3)
  - I2S and PCM cannot be used at the same time
- PDM
  - Up to 8 channels
  - Audio resolution from 16bits to 24bits
  - Sample rate up to 192KHz
  - Support PDM master receive mode
- TDM
  - supports up to 8 channels for TX and 8 channels RX path
  - Audio resolution from 16bits to 32bits
  - Sample rate up to 192KHz
  - Provides master and slave work mode, software configurable
  - Support 3 I2S formats (normal, left-justified, right-justified)
  - Support 4 PCM formats (early, late1, late2, late3)

### 1.2.13 Connectivity

- SDIO interface
  - Compatible with SDIO3.0 protocol
  - 4bits data bus widths
- USB 2.0
  - Built-in one USB 2.0 OTG interfaces
  - Compatible with USB 2.0 specification
  - Supports high-speed(480Mbps), full-speed(12Mbps) and low-speed(1.5Mbps) mode
  - Provides 16 host mode channels
  - Support periodic out channel in host mode
- SPI interface
  - Support two SPI Controller
  - Support serial-master and serial-slave mode, software-configurable
- I2C interface
  - Support four I2C interface(I2C0/I2C1/I2C2)
  - Support 7bits and 10bits address mode
  - Software programmable clock frequency
  - Data on the I2C-bus can be transferred at rates of up to 100 kbit/s in the Standard-mode, up to 400 kbit/s in the Fast-mode or up to 1 Mbit/s in Fast-mode Plus.
- UART Controller
  - Support 2 UART interface(UART1/UART2)
  - Embedded two 64-byte FIFO for TX and RX operation respectively
  - Support 5bit,6bit,7bit,8bit serial data transmit or receive
  - Standard asynchronous communication bits such as start, stop and parity
  - Support different input clock for UART operation to get up to 4Mbps baud rate
  - Support auto flow control mode for UART1TCK

### 1.2.14 Others

- Multiple group of GPIO
  - All of GPIOs can be used to generate interrupt to CPU
  - Support level trigger and edge trigger interrupt
  - Support configurable polarity of level trigger interrupt
  - Support configurable rising edge, falling edge and both edge trigger interrupt
- Temperature Sensor(TS-ADC)
  - Up to 50KS/s sampling rate
  - Support two temperature sensor
  - -20~120°C temperature range and 5°C temperature resolution
- Successive Approximation ADC (SARADC)
  - 10-bit resolution
  - Up to 1MS/s sampling rate
  - 3 single-ended input channels
- OTP
  - Support 4K bit Size, 3.5K bit for secure application
  - Support Program/Read/Idle mode
- Package Type
  - TFBGA395L (body: 14mm x 14mm; ball size: 0.3mm; ball pitch: 0.65mm)

Notes:

① *DDR3/DDR3L/LPDDR2/LPDDR3/DDR4 are not used simultaneously*

Rockchip Confidential



### 1.3 Block Diagram

The following diagram shows the basic block diagram.

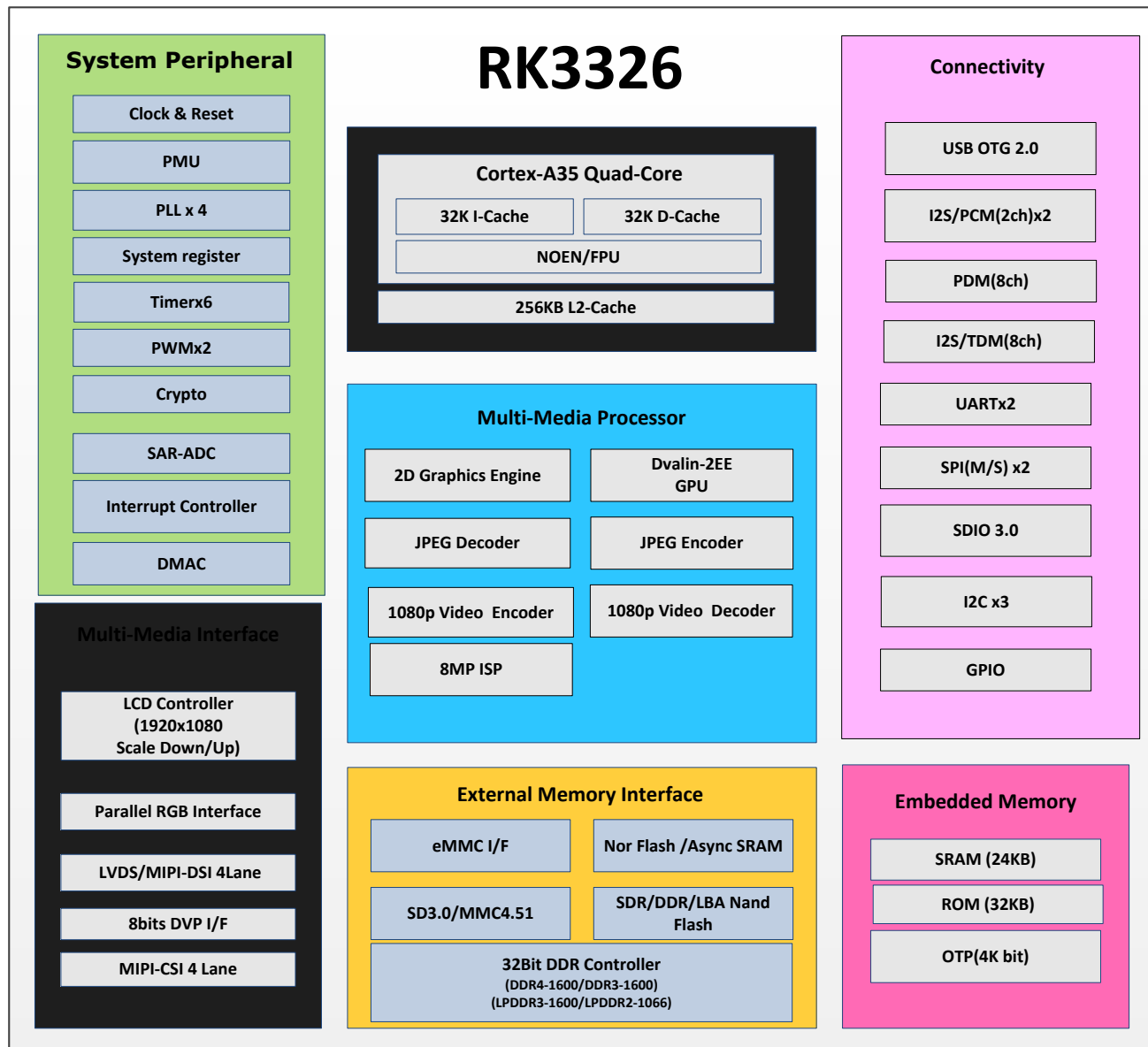

Fig.1-1 Block Diagram

## Chapter 2 Package Information

### 2.1 Order Information

Orderable Device	RoHS status	Package	Package Qty	Device Feature
RK3326	RoHS	TFBGA395L	1190	Quad core application processor

### 2.2 Top Marking

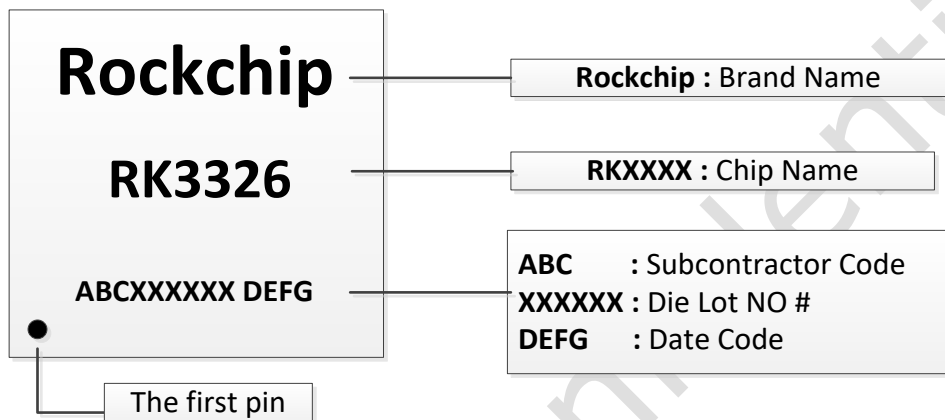

Fig.2-1 Package definition

### 2.3 TFBGA395L Dimension

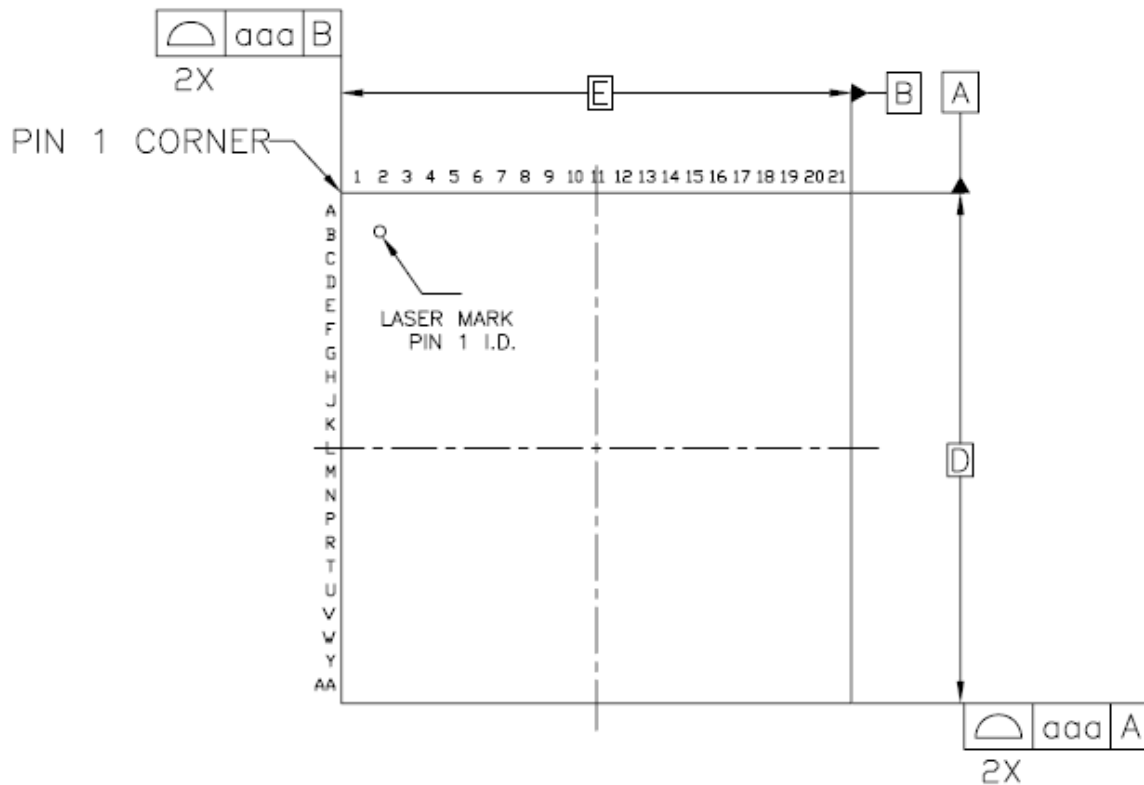
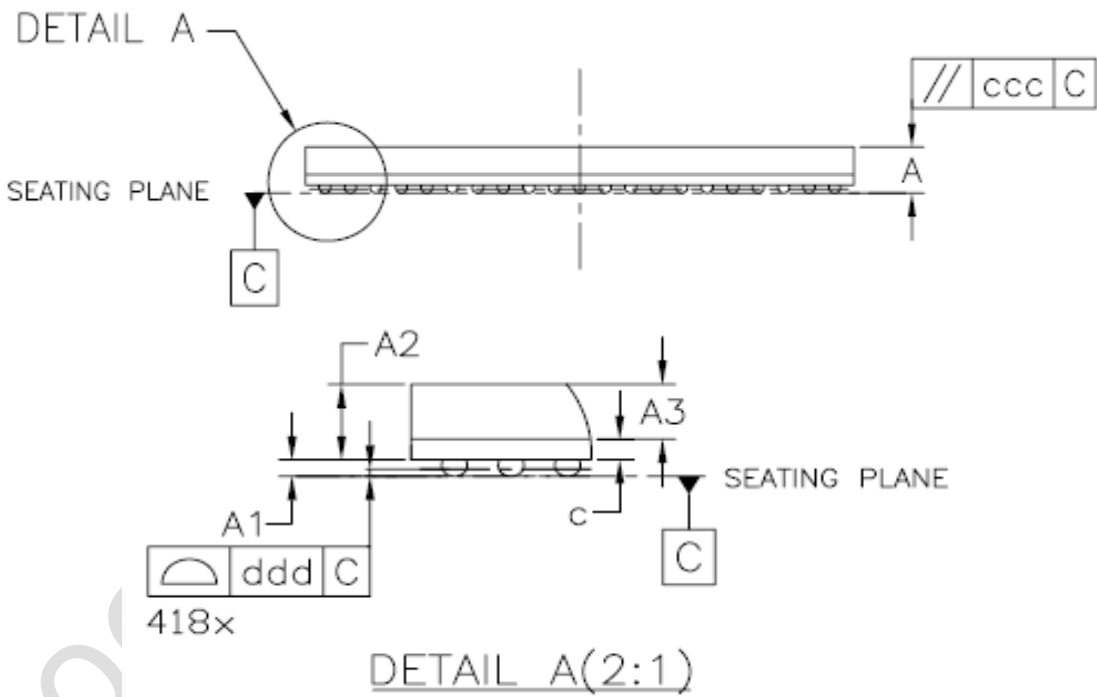
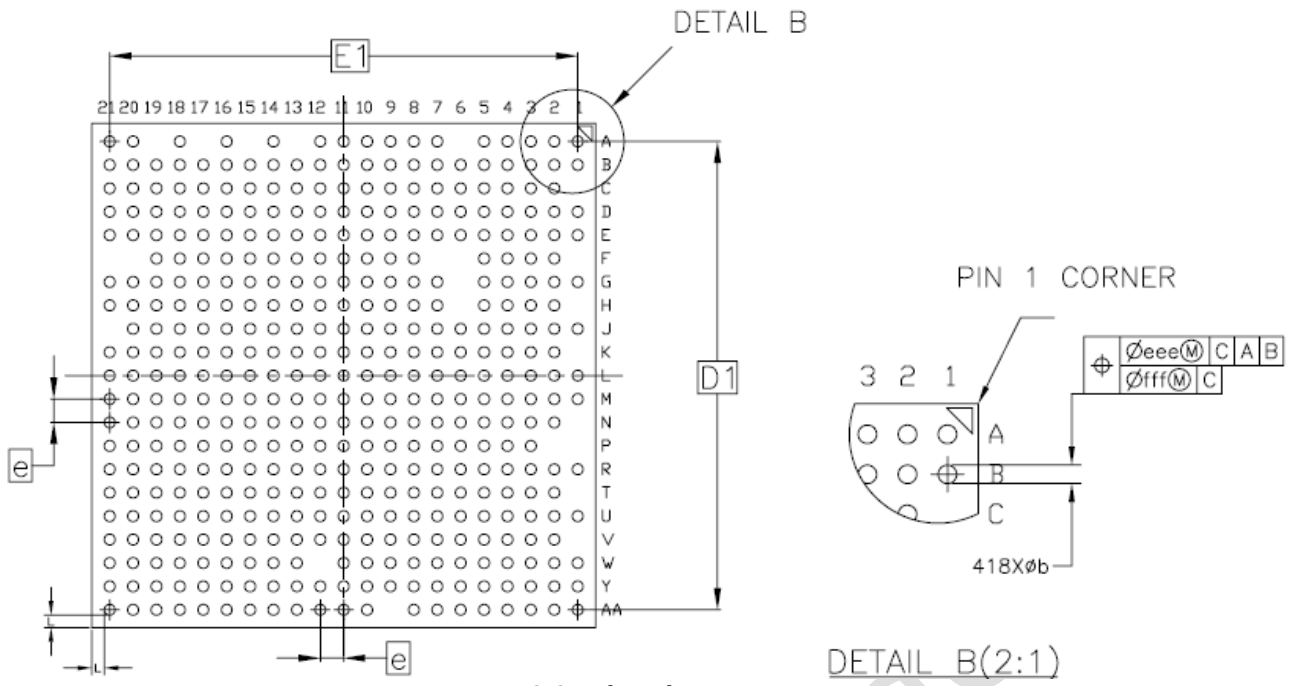

Fig.2-2 Package Top View



SYMBOL	MILLIMETER		
	MIN	NOM	MAX
A	--	1.17	1.25
A1	0.16	0.21	0.26
A2	0.91	0.96	1.01
A3	0.70 BASIC		
c	0.22	0.26	0.30
D	13.90	14.00	14.10
D1	13.00 BASIC		
E	13.90	14.00	14.10
E1	13.00 BASIC		
e	0.65 BASIC		
b	0.25	0.30	0.35
L	0.35 REF		
aaa	0.15		
ccc	0.15		
ddd	0.10		
eee	0.15		
fff	0.08		

Fig.2-5 Package dimension

## 2.4 Ball Map

418

	1	2	3	4	5	6	7	8	9	10	11
A	VSS_1	DDR3_R ESETN/D DR4_RE SETN	DDR3_B A0/DDR4 _BG0	DDR3_A 5/DDR4 _A8	DDR3_BA2/D DR4_BA0		DDR3_ A14/DD R4_A1	DDR3_A 4/DDR4 _A5	DDR3_A 12/DDR 4_BA1	DDR3_A10/D DR4_CS0N	VSS_5
B	DDR3_ CLKN/ DDR4_ CLKN	DDR3_C LKP/DDR 4_CLKP	DDR3_C SN0/DDR 4_ACTN	DDR3_A 7/DDR4 _A11	DDR3_A3/DD R4_A6	VSS_6	DDR3_ A11/DD R4_A3	DDR3_A 6/DDR4 _A7	VSS_7	DDR3_BA1/ DDR4_CASN /DDR4_A15	DDR3_CKE/ DDR4_RASN /DDR4_A16
C		DDR_DQ 26	VSS_8	DDR3_R ASN/DD R4_CKE	VSS_9	DDR3_ A9/DD R4_A0	DDR3_ A0/DD R4_A10	DDR3_ WEN/DD R4_BG1	DDR3_A 15/DDR 4_ODT0	DDR3_A8/D DR4_A13	DDR3_ODT1 /DDR4_ODT 1
D	DDR_D Q30	DDR_DQ 27	VSS_11	VSS_12	DDR3_ODT0/ DDR4_WEN/ DDR4_A14	DDR3_ A13/DD R4_A2	VSS_1 3	DDR3_A 2/DDR4 _A4	DDR3_C ASN/DD R4_A12	DDR3_A1/D DR4_A9	DDR3_CSN1 /DDR4_CS1 N
E	DDR_D Q31	DDR_DQ 22	VSS_14	VSS_15	VSS_16	VSS_1 7	VSS_1 8	VSS_19	VSS_20	VSS_21	VSS_24
F		VSS_22	DDR_DQ 18	DDR_DQ 16	VSS_23			DDRIO_ VDD_1	DDRIO_ VDD_2	DDRIO_VDD _3	MIPI_DSI_V CCA_1V0
G	DDR_D QS3_N	DDR_DQ S3_P	DDR_DQ 17	DDR_DM 2	VSS_28		VSS_2 9	VSS_30	DDRIO_ VDD_4	DDRIO_VDD _5	VSS_31
H		VSS_37	VSS_38	VSS_39	VSS_40		VSS_4 1	VSS_42	VSS_43	VSS_44	VSS_45
J	DDR_D QS2_N	DDR_DQ S2_P	DDR_DQ 29	DDR_DQ 25	VSS_49	DDRIO_ _VDD_ 6	DDRIO_ _VDD_ 7	VSS_50	VSS_51	VSS_52	VSS_53

Fig.2-6Ball Map-1

12	13	14	15	16	17	18	19	20	21	
LVDS_TX3P/MIPI_TX_D3P/LCDC_DEN_M1		LVDS_CLKP/MIPI_TX_CLKP/LCDC_D3_M1		LVDS_TX1P/MIPI_TX_D1P/LCDC_D10_M1		GPIO3_C5/LCDC_D17/I2S0_8CH_SDI0/TDM_SDI		GPIO3_C0/LCDC_D12/I2S0_8CH_SDI01	VSS_2	A
LVDS_TX3N/MIPI_TX_D3N/LCDC_HSYNC_M1	LVDS_TX2P/MIPI_TX_D2P/LCDC_D5_M1	LVDS_CLKN/MIPI_TX_CLKN/LCDC_D4_M1	LVDS_TX1N/MIPI_TX_D1N/LCDC_D1_M1	LVDS_TX0N/MIPI_TX_D0N/LCDC_D11_M1	LVDS_TX0P/MIPI_TX_D0P/LCDC_D8_M1	GPIO3_B2/LCDC_D6/SPI1_CSN1	GPIO3_C3/LCDC_D15/I2S0_8CH_SDI0/CLKTX/TDM_SCLK	GPIO3_C1/LCDC_D13/I2S0_8CH_MCLK	GPIO1_A7/FLASH_D7/EMMC_D7	B
VSS_10	LVDS_TX2N/MIPI_TX_D2N/LCDC_VSYNC_M1	GPIO3_A6/LCDC_D2	GPIO3_A4/LCDC_D0	GPIO3_B5/LCDC_D9_M0/I2S0_8CH_LRCKRX	GPIO3_B3/LCDC_D7/I2S0_8CH_SDI1	GPIO3_C4/LCDC_D16/I2S0_8CH_SDI0/TDM_SDI0	GPIO3_C2/LCDC_D14/I2S0_8CH_LDI0/RCKTX/TDM_FSYNC	GPIO1_A6/FLASH_D6/EMMC_D6	GPIO1_A2/FLASH_D2/EMMC_D2/SFC_SIO2	C
VCCIO4	GPIO3_C6/LCDC_D18/PDM_CLK0_M0	GPIO3_C7/LCDC_D19/PDM_CLK1	GPIO3_D0/LCDC_D20/CIF_CLKOUT_M1/PDM_SDI1	GPIO3_D1/LCDC_D21/CIF_VSYNC_M1/PDM_SDI2/ISP_PRELIGHT/TRIG	GPIO3_D2/LCDC_D22/CIF_HREF_M1/PDM_SDI3/ISP_FLASH_TRIGOUT	GPIO3_D3/LCDC_D23/CIF_CLKIN_M1/PDM_SDI0_M0/ISP_FLASH_TRIGIN	GPIO3_A0/LCDC_CLK	GPIO1_A5/FLASH_D5/EMMC_D5	GPIO1_A1/FLASH_D1/EMMC_D1/SFC_SIO1	D
MIPI_DSI_VCCA_3V3	GPIO3_A1/LCDC_HS_YNC_M0/I2S2_2CH_MCLK	GPIO3_A3/LCDC_DEN_M0/CIF_D2_M1/I2S2_2CH_LRCK_TXRX	GPIO3_A5/LCDC_D1_M0/CIF_D3_M1/I2S2_2CH_SDI	GPIO3_A7/LCDC_D3_M0/CIF_D4_M1/I2S2_2CH_SDI	GPIO3_B0/LCDC_D4_M0/CIF_D5_M1/I2S0_8CH_SDI3	GPIO1_B3/FLASH_ALE/EMMC_RSTN	GPIO1_A3/FLASH_D3/EMMC_D3/SFC_SIO3	GPIO1_A0/FLASH_D0/EMMC_D0/SFC_SIO0	GPIO1_A4/FLASH_D4/EMMC_D4/EMMC_D4/SFC_CSN0	E
MIPI_DSI_VCCA_1V8	GPIO3_A2/LCDC_VSYNC_M0/I2S2_2CH_SCLK	VSS_25	VSS_26	VSS_27	GPIO3_B1/LCDC_D5_M0/CIF_D6_M1/I2S0_8CH_SDI2/SPI1_CSN0	GPIO3_B4/LCDC_D8_M0/CIF_D7_M1/SPI1_MOSI	GPIO1_B0/FLASH_CS0			F
LVDS_RBIAS	VSS_33	VSS_34	VSS_48	VSS_47	GPIO3_B7/LCDC_D11_M0/CIF_D9_M1/I2S0_8CH_SDI02/SPI1_CLK	GPIO3_B6/LCDC_D10_M0/CIF_D8_M1/I2S0_8CH_SDI03/SPI1_MISO	GPIO1_B2/FLASH_DQS/EMMC_CMD_CSN	GPIO1_B6/FLASH_CS1/SPI0_CSN	GPIO1_B4/FLASH_CLE/SPI0_MOSI	G
VSS_46	VSS_55	CPU_VDD_1	CPU_VDD_2	CPU_VDD_3	VSS_57	GPIO1_B1/FLASH_RDY/EMMC_CLKOUT/SFC_CLK	GPIO1_C4/SDMMC1_CMD	GPIO1_B5/FLASH_WRN/SPI0_MISO	GPIO1_B7/FLASH_RDN/SPI0_CLK	H
VSS_54	VSS_64	CPU_VDD_4	CPU_VDD_5	CPU_VDD_6	VSS_56	VCCIO6	GPIO1_C3/UART1_RTS	GPIO1_C2/UART1_CTS		J

Fig.2-7Ball Map-2

K		DDR_ DQ19	DDR_ DQ24	DDR_DQ28	VSS_58	DDRIO_VDD_8	DDRIO_VD D_9	VSS_59	LOGIC_ _VDD_ 1	LOGIC_ VDD_3	VSS_61
L	DDR_D Q23	DDR_ DQ20	VSS_ 70	VSS_71	VSS_72	DDRIO_VDD_10	DDRIO_VD D_11	VSS_73	LOGIC_ _VDD_ 2	LOGIC_ VDD_4	LOGIC_ VDD_9
M	DDR_D Q21	DDR_ DQ11	DDR_ DQ13	DDR_DM3	VSS_80	DDRIO_VDD_12	DDRIO_VD D_13	VSS_81	VSS_8 4	VSS_85	LOGIC_ VDD_8
N		DDR_ DQ4	VSS_ 89	DDR_DQ15	VSS_90	VSS_91	VSS_92	VSS_93	VSS_9 6	VSS_97	LOGIC_ VDD_5
P			DDR_ DQ9	VSS_100	VSS_101	VSS_102	VSS_103	VSS_104	VSS_1 05	VSS_10 6	VSS_10 7
R	DDR_D Q1	DDR_ DQ6	DDR_ DQ5	DDR_DQ0	VSS_113	VSS_114	VSS_115	VSS_116	VSS_1 17	VSS_11 8	VSS_11 9
T		DDR_ D_M0	VSS_ 126	VSS_127	VSS_128	VSS_129	VSS_130	VSS_131	VSS_1 32	VSS_13 3	VSS_13 4
U	DDR_D QS1_N	DDR_ DQS1_P	DDR_ DQ2	DDR_D_M1	VSS_141	VCCIO3	GPIO2_B7/ I2C2_SCL	MIPI_CSI_ VCCA_1V0	MIPI_C SI_DP2	MIPI_C SI_CLK N	MIPI_CS I_RBIA S
V		VSS_1 47	DDR_ DQ14	DDR_DQ12	VSS_148	GPIO2_C0/I2 C2_SDA	GPIO2_B5	MIPI_CSI_ DN2	MIPI_C SI_DP3	MIPI_C SI_CLK P	MIPI_CS I_DN0
W	DDR_D QS0_N	DDR_ DQS0_P	VSS_ 32	VSS_135	GPIO2_A6/C IF_D8_M0	GPIO2_B6/U ART2_RX_M 1	GPIO2_A7/ CIF_D9_M0	MIPI_CSI_ DN3	MIPI_C SI_DN 1	MIPI_C SI_DP0	VSS_35
Y	DDR_D Q7	DDR_ DQ3	DDR_ DQ10	GPIO2_B0/CI F_VSYNC_M0	GPIO2_B3/C IF_CLKO_M0	GPIO2_A3/C IF_D5_M0	GPIO2_A5/ CIF_D7_M0	GPIO2_A4/ CIF_D6_M0	MIPI_C SI_DP1	USB_O TG_DP	USB_ID
A	VSS_4	DDR_ DQ8	VSS_ 98	GPIO2_B1/CI F_HREF_M0	GPIO2_A0/C IF_D2_M0	GPIO2_B2/C IF_CLKI_M0	GPIO2_A2/ CIF_D4_M0	GPIO2_A1/ CIF_D3_M0		USB_O TG_DM	USB_RB IAS
	1	2	3	4	5	6	7	8	9	10	11

Fig.2-8Ball Map-3

VSS_6 3	VSS_65	CPU_VD D_7	CPU_VDD _8	CPU_VDD _9	VSS_67	VSS_68	VCCIO1	GPIO1_C5/ SDMMC1_C LK	GPIO1_C6/SD MMC1_D0	K
VSS_7 7	VSS_69	VSS_66	VSS_87	VSS_88	VSS_78	VSS_79	GPIO1_D0/ SDMMC1_D 2	GPIO1_D1/ SDMMC1_D 3	GPIO1_C7/SD MMC1_D1	L
VSS_6 2	VSS_60	VSS_75	VSS_82	VSS_83	VSS_86	PLL_AVDD_ 1V8	GPIO0_B7/ PWM0/OTG _DRV	GPIO1_C0/ UART1_RX	GPIO1_C1/UA RT1_TX	M
LOGIC _VDD_ 7	LOGIC_VDD _6	VSS_74	VSS_94	VSS_95	AVSS	PLL_AVDD_ 1V0	GPIO0_B5/ TEST_CLK1	GPIO0_B2	GPIO0_C0/P WM1	N
VSS_1 08	VSS_109	VSS_110	VSS_112	VSS_111	PMU_VDD_ 1V0	GPIO0_B3	GPIO0_C1	GPIO0_C4/ CLKIO_32K	GPIO0_B1/I2 C0_SDA	P
VSS_1 20	VSS_121	VSS_122	VSS_123	VSS_124	VSS_125	GPIO0_B4	GPIO0_B6/ FLASH_VO LSEL	GPIO0_C3/I 2C1_SDA	GPIO0_B0/I2 C0_SCL	R
VSS_3 6	OTP_VCC_1 V8	VSS_136	VSS_137	VSS_138	VSS_139	VSS_140	PMUIO2	GPIO0_C2/I 2C1_SCL	GPIO0_A5	T
USB_A VDD_1 V0	ADC_AVDD_ 1V8	VSS_142	VSS_143	VSS_144	VSS_145	VSS_146	PMUIO1	OSC_24M_I N	OSC_24M_OU T	U
GPIO2_ B4/UA RT2_T X_M1	USB_AVDD_ 1V8	ADC_IN 0	ADC_IN2	VSS_149	VSS_150	VSS_151	VSS_152	GPIO0_A4/P MIC_SLEEP/ TSADC_SHU T_M1	GPIO0_A2	V
	USB_AVDD_ 3V3	ADC_IN 1	GPIO2_C 6/PDM_C LK0_M1	VCCIO5	VSS_99	VSS_76	TVSS	NPOR	GPIO0_A6/TS ADC_SHUT_M 0/TSADC_SH UTORG	W
NC_1	USB_VBUS	GPIO2_ C3/I2S1 _2CH_M CLK	GPIO2_C 4/I2S1_2 CH_SDO	GPIO1_D4 /SDMMC0 _D2/JTAG _TCK	GPIO1_D3/ SDMMC0_D 1/UART2_R X_M0	VCCIO2	GPIO0_A7	GPIO0_A1	GPIO0_A0/RE F_CLKO	Y
NC_2	GPIO2_C5/I 2S1_2CH_S DI//PDM_S DIO_M1	GPIO2_ C2/I2S1 _2CH_ SCLK	GPIO2_C 1/I2S1_2 CH_LRCK _TXRX	GPIO1_D5 /SDMMC0 _D3/JTAG _TMS	GPIO1_D7/ SDMMC0_C MD	GPIO1_D2/ SDMMC0_D 0/UART2_T X_M0	GPIO1_D6/ SDMMC0_C LKO/TEST_ CLKO	GPIO0_A3/S DMMC0_DE TN	VSS_3	A A
12	13	14	15	16	17	18	19	20	21	-

Fig.2-9Ball Map-4



## 2.5 Pin Number List

Table 2-1 Pin Number List Information

Pin #	Pin Name	Pin #	Pin Name
A1	VSS_1	L16	VSS_88
A2	DDR3_RESETh/DDR4_RESETh	L17	VSS_78
A3	DDR3_BA0/DDR4_BG0	L18	VSS_79
A4	DDR3_A5/DDR4_A8	L19	GPIO1_D0/SDMMC1_D2
A5	DDR3_BA2/DDR4_BA0	L20	GPIO1_D1/SDMMC1_D3
A7	DDR3_A14/DDR4_A1	L21	GPIO1_C7/SDMMC1_D1
A8	DDR3_A4/DDR4_A5	M1	DDR_DQ21
A9	DDR3_A12/DDR4_BA1	M2	DDR_DQ11
A10	DDR3_A10/DDR4_CS0n	M3	DDR_DQ13
A11	VSS_5	M4	DDR_DM3
A12	LVDS_TX3P/MIPI_TX_D3P/LCDC_DEN_M1	M5	VSS_80
A14	LVDS_CLKP/MIPI_TX_CLKP/LCDC_D3_M1	M6	DDRIO_VDD_12
A16	LVDS_TX1P/MIPI_TX_D1P/LCDC_D10_M1	M7	DDRIO_VDD_13
A18	GPIO3_C5/LCDC_D17/I2S0_8CH_SDI0/TDM_SDI	M8	VSS_81
A20	GPIO3_C0/LCDC_D12/I2S0_8CH_SDO1	M9	VSS_84
A21	VSS_2	M10	VSS_85
B1	DDR3_CLKN/DDR4_CLKN	M11	LOGIC_VDD_8
B2	DDR3_CLKP/DDR4_CLKP	M12	VSS_62
B3	DDR3_CSN0/DDR4_ACTn	M13	VSS_60
B4	DDR3_A7/DDR4_A11	M14	VSS_75
B5	DDR3_A3/DDR4_A6	M15	VSS_82
B6	VSS_6	M16	VSS_83
B7	DDR3_A11/DDR4_A3	M17	VSS_86
B8	DDR3_A6/DDR4_A7	M18	PLL_AVDD_1V8
B9	VSS_7	M19	GPIO0_B7/PWM0/OTG_DRV
B10	DDR3_BA1/DDR4_CASn/DDR4_A15	M20	GPIO1_C0/UART1_RX
B11	DDR3_CKE/DDR4_RASn/DDR4_A16	M21	GPIO1_C1/UART1_TX
B12	LVDS_TX3N/MIPI_TX_D3N/LCDC_HSYNC_M1	N2	DDR_DQ4
B13	LVDS_TX2P/MIPI_TX_D2P/LCDC_D5_M1	N3	VSS_89
B14	LVDS_CLKN/MIPI_TX_CLKN/LCDC_D4_M1	N4	DDR_DQ15
B15	LVDS_TX1N/MIPI_TX_D1N/LCDC_D1_M1	N5	VSS_90
B16	LVDS_TX0N/MIPI_TX_D0N/LCDC_D11_M1	N6	VSS_91
B17	LVDS_TX0P/MIPI_TX_D0P/LCDC_D8_M1	N7	VSS_92

Pin #	Pin Name	Pin #	Pin Name
B18	GPIO3_B2/LCDC_D6/SPI1_CSN1	N8	VSS_93
B19	GPIO3_C3/LCDC_D15 /I2S0_8CH_SCLKTX/TDM_SCLK	N9	VSS_96
B20	GPIO3_C1/LCDC_D13/I2S0_8CH_MCLK	N10	VSS_97
B21	GPIO1_A7/FLASH_D7/EMMC_D7	N11	LOGIC_VDD_5
C2	DDR_DQ26	N12	LOGIC_VDD_7
C3	VSS_8	N13	LOGIC_VDD_6
C4	DDR3_RASn/DDR4_CKE	N14	VSS_74
C5	VSS_9	N15	VSS_94
C6	DDR3_A9/DDR4_A0	N16	VSS_95
C7	DDR3_A0/DDR4_A10	N17	AVSS
C8	DDR3_WEn/DDR4_BG1	N18	PLL_AVDD_1V0
C9	DDR3_A15/DDR4_ODT0	N19	GPIO0_B5/ TEST_CLK1
C10	DDR3_A8/DDR4_A13	N20	GPIO0_B2
C11	DDR3_ODT1/DDR4_ODT1	N21	GPIO0_C0/ PWM1
C12	VSS_10	P3	DDR_DQ9
C13	LVDS_TX2N/MIPI_TX_D2N/LCDC_VSYNC_M1	P4	VSS_100
C14	GPIO3_A6/LCDC_D2	P5	VSS_101
C15	GPIO3_A4/LCDC_D0	P6	VSS_102
C16	GPIO3_B5/LCDC_D9_M0/I2S0_8CH_LRCKRX	P7	VSS_103
C17	GPIO3_B3/LCDC_D7/I2S0_8CH_SDI1	P8	VSS_104
C18	GPIO3_C4/LCDC_D16 /I2S0_8CH_SDO0/TDM_SDO	P9	VSS_105
C19	GPIO3_C2/LCDC_D14 /I2S0_8CH_LRCKTX/TDM_FSYNC	P10	VSS_106
C20	GPIO1_A6/FLASH_D6/EMMC_D6	P11	VSS_107
C21	GPIO1_A2/FLASH_D2/EMMC_D2/SFC_SIO2	P12	VSS_108
D1	DDR_DQ30	P13	VSS_109
D2	DDR_DQ27	P14	VSS_110
D3	VSS_11	P15	VSS_112
D4	VSS_12	P16	VSS_111
D5	DDR3_ODT0/DDR4_Wen/DDR4_A14	P17	PMU_VDD_1V0
D6	DDR3_A13/DDR4_A2	P18	GPIO0_B3
D7	VSS_13	P19	GPIO0_C1
D8	DDR3_A2/DDR4_A4	P20	GPIO0_C4/CLKIO_32K
D9	DDR3_CASn/DDR4_A12	P21	GPIO0_B1/I2C0_SDA
D10	DDR3_A1/DDR4_A9	R1	DDR_DQ1
D11	DDR3_CSN1/DDR4_CS1N	R2	DDR_DQ6
D12	VCCIO4	R3	DDR_DQ5

Pin #	Pin Name	Pin #	Pin Name
D13	GPIO3_C6/LCDC_D18/PDM_CLK0_M0	R4	DDR_DQ0
D14	GPIO3_C7/LCDC_D19/PDM_CLK1	R5	VSS_113
D15	GPIO3_D0/LCDC_D20/CIF_CLKOUT_M1/PDM_SDI1	R6	VSS_114
D16	GPIO3_D1/LCDC_D21/CIF_VSYNC_M1/PDM_SDI2/ISP_PRELIGHT_TRIG	R7	VSS_115
D17	GPIO3_D2/LCDC_D22/CIF_HREF_M1/PDM_SDI3/ISP_FLASH_TRIGOUT	R8	VSS_116
D18	GPIO3_D3/LCDC_D23/CIF_CLKIN_M1/PDM_SDI0_M0/ISP_FLASH_TRIGIN	R9	VSS_117
D19	GPIO3_A0/LCDC_CLK	R10	VSS_118
D20	GPIO1_A5/FLASH_D5/EMMC_D5	R11	VSS_119
D21	GPIO1_A1/FLASH_D1/EMMC_D1/SFC_SIO1	R12	VSS_120
E1	DDR_DQ31	R13	VSS_121
E2	DDR_DQ22	R14	VSS_122
E3	VSS_14	R15	VSS_123
E4	VSS_15	R16	VSS_124
E5	VSS_16	R17	VSS_125
E6	VSS_17	R18	GPIO0_B4
E7	VSS_18	R19	GPIO0_B6/FLASH_VOLSEL
E8	VSS_19	R20	GPIO0_C3/I2C1_SDA
E9	VSS_20	R21	GPIO0_B0/I2C0_SCL
E10	VSS_21	T2	DDR_D_m0
E11	VSS_24	T3	VSS_126
E12	MIPI_DSI_VCCA_3V3	T4	VSS_127
E13	GPIO3_A1/LCDC_HSYNC_M0/ I2S2_2CH_MCLK	T5	VSS_128
E14	GPIO3_A3/LCDC_DEN_M0/CIF_D2_M1/I2S2_2CH_LRCK_TXRX	T6	VSS_129
E15	GPIO3_A5/LCDC_D1_M0/CIF_D3_M1/I2S2_2CH_SDI	T7	VSS_130
E16	GPIO3_A7/LCDC_D3_M0/CIF_D4_M1/I2S2_2CH_SDO	T8	VSS_131
E17	GPIO3_B0/LCDC_D4_M0/CIF_D5_M1/I2S0_8CH_SDI3	T9	VSS_132
E18	GPIO1_B3/FLASH_ALE/EMMC_RSTN	T10	VSS_133
E19	GPIO1_A3/FLASH_D3/EMMC_D3/SFC_SIO3	T11	VSS_134
E20	GPIO1_A0/FLASH_D0/EMMC_D0/SFC_SIO0	T12	VSS_36
E21	GPIO1_A4/FLASH_D4/EMMC_D4/SFC_CSNO	T13	OTP_VCC_1V8
F2	VSS_22	T14	VSS_136
F3	DDR_DQ18	T15	VSS_137

Pin #	Pin Name	Pin #	Pin Name
F4	DDR_DQ16	T16	VSS_138
F5	VSS_23	T17	VSS_139
F8	DDRIO_VDD_1	T18	VSS_140
F9	DDRIO_VDD_2	T19	PMUIO2
F10	DDRIO_VDD_3	T20	GPIO0_C2/I2C1_SCL
F11	MIPI_DSI_VCCA_1V0	T21	GPIO0_A5
F12	MIPI_DSI_VCCA_1V8	U1	DDR_DQS1_N
F13	GPIO3_A2/LCDC_VSYNC_M0/ I2S2_2CH_SCLK	U2	DDR_DQS1_P
F14	VSS_25	U3	DDR_DQ2
F15	VSS_26	U4	DDR_D_M1
F16	VSS_27	U5	VSS_141
F17	GPIO3_B1/LCDC_D5_M0/CIF_D6_M1/I2S0_8CH_SDI2/SPI1_CSN0	U6	VCCIO3
F18	GPIO3_B4/LCDC_D8_M0/CIF_D7_M1/I2S0_8CH_SCLKRX/SPI1_MOSI	U7	GPIO2_B7/I2C2_SCL
F19	GPIO1_B0/FLASH_CS0	U8	MIPI_CSI_VCCA_1V0
G1	DDR_DQS3_N	U9	MIPI_CSI_DP2
G2	DDR_DQS3_P	U10	MIPI_CSI_CLKN
G3	DDR_DQ17	U11	MIPI_CSI_RBIAS
G4	DDR_DM2	U12	USB_AVDD_1V0
G5	VSS_28	U13	ADC_AVDD_1V8
G7	VSS_29	U14	VSS_142
G8	VSS_30	U15	VSS_143
G9	DDRIO_VDD_4	U16	VSS_144
G10	DDRIO_VDD_5	U17	VSS_145
G11	VSS_31	U18	VSS_146
G12	LVDS_RBIAS	U19	PMUIO1
G13	VSS_33	U20	OSC_24M_IN
G14	VSS_34	U21	OSC_24M_OUT
G15	VSS_48	V2	VSS_147
G16	VSS_47	V3	DDR_DQ14
G17	GPIO3_B7/LCDC_D11_M0/CIF_D9_M1/I2S0_8CH_SDO2/SPI1_CLK	V4	DDR_DQ12
G18	GPIO3_B6/LCDC_D10_M0/CIF_D8_M1/I2S0_8CH_SDO3/SPI1_MISO	V5	VSS_148
G19	GPIO1_B2/FLASH_DQS/EMMC_CMD	V6	GPIO2_C0/I2C2_SDA
G20	GPIO1_B6/FLASH_CS1/ SPI0_CSN	V7	GPIO2_B5
G21	GPIO1_B4/FLASH_CLE/SPI0_MOSI	V8	MIPI_CSI_DN2
H2	VSS_37	V9	MIPI_CSI_DP3
H3	VSS_38	V10	MIPI_CSI_CLKP
H4	VSS_39	V11	MIPI_CSI_DN0
H5	VSS_40	V12	GPIO2_B4/ UART2_TX_M1

Pin #	Pin Name	Pin #	Pin Name
H7	VSS_41	V13	USB_AVDD_1V8
H8	VSS_42	V14	ADC_IN0
H9	VSS_43	V15	ADC_IN2
H10	VSS_44	V16	VSS_149
H11	VSS_45	V17	VSS_150
H12	VSS_46	V18	VSS_151
H13	VSS_55	V19	VSS_152
H14	CPU_VDD_1	V20	GPI00_A4/PMIC_SLEEP/TSADC_SHUT_M1
H15	CPU_VDD_2	V21	GPI00_A2
H16	CPU_VDD_3	W1	DDR_DQS0_N
H17	VSS_57	W2	DDR_DQS0_P
H18	GPI01_B1/FLASH_RDY/EMMC_CLKOUT/SFC_CLK	W3	VSS_32
H19	GPI01_C4/SDMMC1_CMD	W4	VSS_135
H20	GPI01_B5/FLASH_WRN/ SPIO_MISO	W5	GPI02_A6/CIF_D8_M0
H21	GPI01_B7/FLASH_RDN/ SPIO_CLK	W6	GPI02_B6/UART2_RX_M1
J1	DDR_DQS2_N	W7	GPI02_A7/CIF_D9_M0
J2	DDR_DQS2_P	W8	MIPI_CSI_DN3
J3	DDR_DQ29	W9	MIPI_CSI_DN1
J4	DDR_DQ25	W10	MIPI_CSI_DP0
J5	VSS_49	W11	VSS_35
J6	DDRIO_VDD_6	W13	USB_AVDD_3V3
J7	DDRIO_VDD_7	W14	ADC_IN1
J8	VSS_50	W15	GPI02_C6/PDM_CLK0_M1
J9	VSS_51	W16	VCCIO5
J10	VSS_52	W17	VSS_99
J11	VSS_53	W18	VSS_76
J12	VSS_54	W19	TVSS
J13	VSS_64	W20	NPOR
J14	CPU_VDD_4	W21	GPI00_A6/TSADC_SHUT_M0/TSADC_SHUTORG
J15	CPU_VDD_5	Y1	DDR_DQ7
J16	CPU_VDD_6	Y2	DDR_DQ3
J17	VSS_56	Y3	DDR_DQ10
J18	VCCIO6	Y4	GPI02_B0/CIF_VSYNC_M0
J19	GPI01_C3/UART1_RTS	Y5	GPI02_B3/CIF_CLKO_M0
J20	GPI01_C2/UART1_CTS	Y6	GPI02_A3/CIF_D5_M0
K2	DDR_DQ19	Y7	GPI02_A5/CIF_D7_M0
K3	DDR_DQ24	Y8	GPI02_A4/CIF_D6_M0
K4	DDR_DQ28	Y9	MIPI_CSI_DP1
K5	VSS_58	Y10	USB_OTG_DP
K6	DDRIO_VDD_8	Y11	USB_ID

Pin #	Pin Name	Pin #	Pin Name
K7	DDRIO_VDD_9	Y12	NC_1
K8	VSS_59	Y13	USB_VBUS
K9	LOGIC_VDD_1	Y14	GPIO2_C3/I2S1_2CH_MCLK
K10	LOGIC_VDD_3	Y15	GPIO2_C4/I2S1_2CH_SDO
K11	VSS_61	Y16	GPIO1_D4/SDMMC0_D2/ JTAG_TCK
K12	VSS_63	Y17	GPIO1_D3/SDMMC0_D1
K13	VSS_65	Y18	VCCIO2
K14	CPU_VDD_7	Y19	GPIO0_A7
K15	CPU_VDD_8	Y20	GPIO0_A1
K16	CPU_VDD_9	Y21	GPIO0_A0/REF_CLKO
K17	VSS_67	AA1	VSS_4
K18	VSS_68	AA2	DDR_DQ8
K19	VCCIO1	AA3	VSS_98
K20	GPIO1_C5/SDMMC1_CLK	AA4	GPIO2_B1/CIF_HREF_M0
K21	GPIO1_C6/SDMMC1_D0	AA5	GPIO2_A0/CIF_D2_M0
L1	DDR_DQ23	AA6	GPIO2_B2/CIF_CLKI_M0
L2	DDR_DQ20	AA7	GPIO2_A2/CIF_D4_M0
L3	VSS_70	AA8	GPIO2_A1/CIF_D3_M0
L4	VSS_71	AA1 0	USB_OTG_DM
L5	VSS_72	AA1 1	USB_RBIAS
L6	DDRIO_VDD_10	AA1 2	NC_2
L7	DDRIO_VDD_11	AA1 3	GPIO2_C5/I2S1_2CH_SDI/PDM_SDIO_M1
L8	VSS_73	AA1 4	GPIO2_C2/I2S1_2CH__SCLK
L9	LOGIC_VDD_2	AA1 5	GPIO2_C1/I2S1_2CH_LRCK_TXRX
L10	LOGIC_VDD_4	AA1 6	GPIO1_D5/SDMMC0_D3/ JTAG_TMS
L11	LOGIC_VDD_9	AA1 7	GPIO1_D7/SDMMC0_CMD/
L12	VSS_77	AA1 8	GPIO1_D2/SDMMC0_D0/UART2_TX_M0
L13	VSS_69	AA1 9	GPIO1_D6/SDMMC0_CLKO/ TEST_CLKO
L14	VSS_66	AA2 0	GPIO0_A3/SDMMC0_DET_N
L15	VSS_87	AA2 1	VSS_3

## 2.6 Power/Ground IO Description

Table 2-2 Power/Ground IO information

Group	Ball#	Descriptions
VSS	A1,A11,A21,B6,B9,C3,C5,C12,D3,D4,D7,E3,E4,E5,E6,E7,E8,E9,E10,E11,F2,F5,F14, F15,F16,G5,G7,G8,G11,G13,G14,G15,G16,H2,H3,H4,H5,H7,H8,H9,H10,H11,H12,H13,H17,J5,J8,J9,J10,J11,J12,J13,J17,K5,K8,K11,K12,K13,K17,K18,L3,L4,L5,L8,L12,L13,L14,L15,L16,L17,L18,M5,M8,M9,M10,M12,M13,M14,M15,M16,M17,N3,N5,N6,N7,N8,N9,N10,N14,N15,N16,P4,P5,P6,P7,P8,P9,P10,P11,P12,P13,P14,P15,P16,R5,R6,R7,R8,R9,R10,R11,R12,R13,R14,R15,R16,R17,T3,T4,T5,T6,T7,T8,T9,T10,T11,T12,T14,T15,T16,T17,T18,U5,U14,U15,U16,U17,U18,V2,V5,V16,V17,V18,V19,W3,W4,W11,W17,W18,W19,AA1,A3,AA21	Internal Core Ground, Digital IO Ground,
AVSS	N17	Analog Ground
CPU_VDD	H14,H15,H16,J14,J15,J16,K14,K15,K16	ARM Core Power
LOGIC_VDD	K9 K10 L9 L10 L11 M11 N11 N12 N13	GPU, Logic Power
PMU_VDD_1V0	P17	PMU digital Power
VCCIO1	K19	VCCIO1 Power Domain Power
VCCIO2	Y18	VCCIO2 Power Domain Power
VCCIO3	U6	VCCIO3 Power Domain Power
VCCIO4	D12	VCCIO4 Power Domain Power
VCCIO5	W16	VCCIO5 Power Domain Power
VCCIO6	J18	VCCIO6 Power Domain Power
PMUIO1	U19	PMU VCCIO1 Power Domain Power
PMUIO2	T19	PMU VCCIO2 Power Domain Power
DDRIO_VDD	F8 F9 F10 G9 G10 J6 J7 K6 K7 L6 L7 M6 M7	DDR PHY Power
PLL_AVDD_1V0	N18	PLL Analog Power
PLL_AVDD_1V8	M18	PLL Analog Power

<b>Group</b>	<b>Ball#</b>	<b>Descriptions</b>
USB_AVDD _1V0	U12	USB OTG2.0I Power
USB_AVDD _1V8	V13	USB OTG2.0/Host2.0 Analog Power
USB_AVDD _3V3	W13	USB OTG2.0/Host2.0 Analog Power
MIPI_DSI_V CCA_1V0	F11	MIPI DSI TX Analog Power
MIPI_DSI_V CCA_1V8	F12	MIPI DSI TX Analog Power
MIPI_DSI_V CCA_3V3	E12	MIPI DSI TX Analog Power
MIPI_CSI_V CCA_1V0	U8	MIPI CSI RX Analog Power
ADC_AVDD _1V8	U13	SARADC Analog Power
OTP_VCC_1 V8	T13	OTP Analog Power



## 2.7 Function IO Description

Table 2-3 Function IO description

Pin	Pin Name	Func1	Func2	Func3	Func4	Func5	Pad Typ e①	Def ③	Pull	Drive Streng th②	INT ④	DIE Power domain
W19	TVSS	TVSS					I	I	up	2		PMUIO1
Y21	GPIO0_A0/REF_CLKO	GPIO0_A0	REF_CLKO				I/O	I	down	4	√	
Y20	GPIO0_A1	GPIO0_A1					I/O	I	down	2	√	
V21	GPIO0_A2	GPIO0_A2					I/O	I	down	2	√	
AA20	GPIO0_A3/SDMMC0_DET_N	GPIO0_A3	SDMMC0_DET_N				I/O	I	up	2	√	
V20	GPIO0_A4/PMIC_SLEEP/TSADC_SHUT_M1	GPIO0_A4	PMIC_SLEEP	TSADC_SHUT_M1			I/O	I	down	2	√	
T21	GPIO0_A5	GPIO0_A5					I/O	I	up	2	√	
W21	GPIO0_A6/TSADC_SHUT_M0/TSADC_SHUT_ORG	GPIO0_A6	TSADC_SHUT_M0	TSADC_SHUT_ORG			I/O	I	z	2	√	
Y19	GPIO0_A7	GPIO0_A7					I/O	I	up	2	√	
R21	GPIO0_B0/I2C0_SCL	GPIO0_B0	I2C0_SCL				I/O	I	up	2	√	
P21	GPIO0_B1/I2C0_SDA	GPIO0_B1	I2C0_SDA				I/O	I	up	2	√	
N20	GPIO0_B2	GPIO0_B2					I/O	I	down	2	√	
P18	GPIO0_B3	GPIO0_B3					I/O	I	down	2	√	
R18	GPIO0_B4	GPIO0_B4					I/O	I	up	2	√	
N19	GPIO0_B5/TEST_CLK1	GPIO0_B5		TEST_CLK1			I/O	I	up	2	√	
R19	GPIO0_B6/FLASH_VOLSEL	GPIO0_B6	FLASH_VOLSEL				I/O	I	up	2	√	
M19	GPIO0_B7/PWM0/OTG_DRV	GPIO0_B7	PWM0	OTG_DRV			I/O	I	down	2	√	
N21	GPIO0_C0/PWM1	GPIO0_C0		PWM1			I/O	I	down	2	√	
P19	GPIO0_C1	GPIO0_C1					I/O	I	down	2	√	
T20	GPIO0_C2/I2C1_SCL	GPIO0_C2	I2C1_SCL				I/O	I	down	2	√	
R20	GPIO0_C3/I2C1_SDA	GPIO0_C3	I2C1_SDA				I/O	I	down	2	√	
P20	GPIO0_C4/CLKIO_32K	GPIO0_C4	CLKIO_32K				I/O	I	z	2	√	

Pin	Pin Name	Func1	Func2	Func3	Func4	Func5	Pad Typ e①	Def ③	Pull	Drive Streng th②	INT ④	DIE Power domain
E20	GPIO1_A0/FLASH_D0/EMMC_D0/SFC_SIO0	GPIO1_A0	FLASH_D0	EMMC_D0	SFC_SIO0		I/O	I	up	8	√	VCCIO6
D21	GPIO1_A1/FLASH_D1/EMMC_D1/SFC_SIO1	GPIO1_A1	FLASH_D1	EMMC_D1	SFC_SIO1		I/O	I	up	8	√	
C21	GPIO1_A2/FLASH_D2/EMMC_D2/SFC_SIO2	GPIO1_A2	FLASH_D2	EMMC_D2	SFC_SIO2		I/O	I	up	8	√	
E19	GPIO1_A3/FLASH_D3/EMMC_D3/SFC_SIO3	GPIO1_A3	FLASH_D3	EMMC_D3	SFC_SIO3		I/O	I	up	8	√	
E21	GPIO1_A4/FLASH_D4/EMMC_D4/SFC_CSNO	GPIO1_A4	FLASH_D4	EMMC_D4	SFC_CSNO		I/O	I	up	8	√	
D20	GPIO1_A5/FLASH_D5/EMMC_D5	GPIO1_A5	FLASH_D5	EMMC_D5			I/O	I	up	8	√	
C20	GPIO1_A6/FLASH_D6/EMMC_D6	GPIO1_A6	FLASH_D6	EMMC_D6			I/O	I	up	8	√	
B21	GPIO1_A7/FLASH_D7/EMMC_D7	GPIO1_A7	FLASH_D7	EMMC_D7			I/O	I	up	8	√	
F19	GPIO1_B0/FLASH_CS0	GPIO1_B0	FLASH_CS0				I/O	I	up	8	√	
H18	GPIO1_B1/FLASH_RDY/EMMC_CLKOUT/SFC_CLK	GPIO1_B1	FLASH_RDY	EMMC_CLKOUT	SFC_CLK		I/O	I	up	8	√	
G19	GPIO1_B2/FLASH_DQS/EMMC_CMD	GPIO1_B2	FLASH_DQS	EMMC_CMD			I/O	I	up	8	√	
E18	GPIO1_B3/FLASH_ALE/EMMC_RSTN	GPIO1_B3	FLASH_ALE	EMMC_RSTN			I/O	I	down	8	√	
G21	GPIO1_B4/FLASH_CLE/ SPI0_MOSI	GPIO1_B4	FLASH_CLE		SPI0_MOSI		I/O	I	down	8	√	
H20	GPIO1_B5/FLASH_WRN/ SPI0_MISO	GPIO1_B5	FLASH_WRN		SPI0_MISO		I/O	I	up	8	√	
G20	GPIO1_B6/FLASH_CS1/ SPI0_CSN	GPIO1_B6	FLASH_CS1		SPI0_CSN		I/O	I	up	8	√	
H21	GPIO1_B7/FLASH_RDN/ SPI0_CLK	GPIO1_B7	FLASH_RDN		SPI0_CLK		I/O	I	up	8	√	
J20	GPIO1_C2/UART1_CTS	GPIO1_C2	UART1_CTS				I/O	I	up	4	√	VCCIO1
K20	GPIO1_C5/SDMMC1_CLK	GPIO1_C5	SDMMC1_CLK				I/O	I	up	4	√	
K21	GPIO1_C6/SDMMC1_D0	GPIO1_C6	SDMMC1_D0				I/O	I	up	4	√	
L21	GPIO1_C7/SDMMC1_D1	GPIO1_C7	SDMMC1_D1				I/O	I	up	4	√	
H19	GPIO1_C4/SDMMC1_CMD	GPIO1_C4	SDMMC1_CMD				I/O	I	up	8	√	
M20	GPIO1_C0/UART1_RX	GPIO1_C0	UART1_RX				I/O	I	down	8	√	
L20	GPIO1_D1/SDMMC1_D3	GPIO1_D1	SDMMC1_D3				I/O	I	up	8	√	
L19	GPIO1_D0/SDMMC1_D2	GPIO1_D0	SDMMC1_D2				I/O	I	up	8	√	
M21	GPIO1_C1/UART1_TX	GPIO1_C1	UART1_TX				I/O	I	up	8	√	
J19	GPIO1_C3/UART1_RTS	GPIO1_C3	UART1_RTS				I/O	I	up	8	√	
AA17	GPIO1_D7/SDMMC0_CMD/	GPIO1_D7	SDMMC0_CMD				I/O	I	up	8	√	VCCIO2

Pin	Pin Name	Func1	Func2	Func3	Func4	Func5	Pad Typ e①	Def ③	Pull	Drive Streng th②	INT ④	DIE Power domain
AA18	GPIO1_D2/SDMMC0_D0/UART2_TX_M0	GPIO1_D2	SDMMC0_D0	UART2_TX_M0			I/O	I	up	8	√	
AA19	GPIO1_D6/SDMMC0_CLKO/TEST_CLKO	GPIO1_D46	SDMMC0_CLKO		TEST_CLKO		I/O	I	up	8	√	
AA16	GPIO1_D5/SDMMC0_D3/ JTAG_TMS	GPIO1_D5	SDMMC0_D3		JTAG_TMS		I/O	I	up	8	√	
Y17	GPIO1_D3/SDMMC0_D1/UART2_RX_M0	GPIO1_D3	SDMMC0_D1		UART2_RX_M0		I/O	I	down	8	√	
Y16	GPIO1_D4/SDMMC0_D2/ JTAG_TCK	GPIO1_D4	SDMMC0_D2		JTAG_TCK		I/O	I	up	8	√	
AA5	GPIO2_A0/CIF_D2_M0	GPIO2_A0	CIF_D2_M0				I/O	I	down	4	√	
AA8	GPIO2_A1/CIF_D3_M0	GPIO2_A1	CIF_D3_M0				I/O	I	down	4	√	
AA7	GPIO2_A2/CIF_D4_M0	GPIO2_A2	CIF_D4_M0				I/O	I	down	4	√	
Y6	GPIO2_A3/CIF_D5_M0	GPIO2_A3	CIF_D5_M0				I/O	I	down	4	√	
Y8	GPIO2_A4/CIF_D6_M0	GPIO2_A4	CIF_D6_M0				I/O	I	down	4	√	
Y7	GPIO2_A5/CIF_D7_M0	GPIO2_A5	CIF_D7_M0				I/O	I	down	4	√	
W5	GPIO2_A6/CIF_D8_M0	GPIO2_A6	CIF_D8_M0				I/O	I	down	4	√	
W7	GPIO2_A7/CIF_D9_M0	GPIO2_A7	CIF_D9_M0				I/O	I	down	4	√	
Y4	GPIO2_B0/CIF_VSYNC_M0	GPIO2_B0	CIF_VSYNC_M0				I/O	I	down	2	√	
AA4	GPIO2_B1/CIF_HREF_M0	GPIO2_B1	CIF_HREF_M0				I/O	I	down	2	√	
AA6	GPIO2_B2/CIF_CLKI_M0	GPIO2_B2	CIF_CLKI_M0				I/O	I	down	2	√	
Y5	GPIO2_B3/CIF_CLKO_M0	GPIO2_B3	CIF_CLKO_M0				I/O	I	down	2	√	
V12	GPIO2_B4/UART2_TX_M1	GPIO2_B4		UART2_TX_M1			I/O	I	down	2	√	
V7	GPIO2_B5	GPIO2_B5					I/O	I	down	2	√	
W6	GPIO2_B6 /UART2_RX_M1	GPIO2_B6		UART2_RX_M1			I/O	I	down	2	√	
U7	GPIO2_B7/ I2C2_SCL	GPIO2_B7		I2C2_SCL			I/O	I	up	2	√	
V6	GPIO2_C0/ I2C2_SDA	GPIO2_C0		I2C2_SDA			I/O	I	up	2	√	
AA15	GPIO2_C1/I2S1_2CH_LRCK_TXRX	GPIO2_C1	I2S1_2CH_LRCK_T XRK				I/O	I	down	4	√	VCCIO5
AA14	GPIO2_C2/I2S1_2CH__SCLK	GPIO2_C2	I2S1_2CH__SCLK				I/O	I	down	4	√	
Y14	GPIO2_C3/I2S1_2CH_MCLK	GPIO2_C3	I2S1_2CH_MCLK				I/O	I	down	4	√	
Y15	GPIO2_C4/I2S1_2CH_SDO	GPIO2_C4	I2S1_2CH_SDO				I/O	I	down	4	√	

Pin	Pin Name	Func1	Func2	Func3	Func4	Func5	Pad Typ e①	Def ③	Pull	Drive Streng th②	INT ④	DIE Power domain
AA13	GPIO2_C5/I2S1_2CH_SDI/PDM_SDIO_M1	GPIO2_C5	I2S1_2CH_SDI	PDM_SDIO_M1			I/O	I	down	4	√	
W15	GPIO2_C6/PDM_CLK0_M1	GPIO2_C6	PDM_CLK0_M1				I/O	I	down	4	√	
D19	GPIO3_A0/LCDC_CLK	GPIO3_A0	LCDC_CLK				I/O	I	down	8	√	
E13	GPIO3_A1/LCDC_HSYNC_M0/ I2S2_2CH_MCLK	GPIO3_A1	LCDC_HSYNC_M0		I2S2_2CH_MCLK		I/O	I	down	8	√	
F13	GPIO3_A2/LCDC_VSYNC_M0/ I2S2_2CH_SCLK	GPIO3_A2	LCDC_VSYNC_M0		I2S2_2CH_SCLK		I/O	I	down	8	√	
E14	GPIO3_A3/LCDC_DEN_M0/CIF_D2_M1/I2S2_2CH_LRCK_T XRX	GPIO3_A3	LCDC_DEN_M0	CIF_D2_M1	XRX		I/O	I	down	8	√	
C15	GPIO3_A4/LCDC_D0	GPIO3_A4	LCDC_D0				I/O	I	down	8	√	
E15	GPIO3_A5/LCDC_D1_M0/CIF_D3_M1/I2S2_2CH_SDI	GPIO3_A5	LCDC_D1_M0	CIF_D3_M1	I2S2_2CH_SDI		I/O	I	down	8	√	
C14	GPIO3_A6/LCDC_D2	GPIO3_A6	LCDC_D2				I/O	I	down	8	√	
E16	GPIO3_A7/LCDC_D3_M0/CIF_D4_M1/I2S2_2CH_SDO	GPIO3_A7	LCDC_D3_M0	CIF_D4_M1	I2S2_2CH_SDO		I/O	I	down	8	√	
E17	GPIO3_B0/LCDC_D4_M0/CIF_D5_M1/I2S0_8CH_SDI3	GPIO3_B0	LCDC_D4_M0	CIF_D5_M1	I2S0_8CH_SDI3		I/O	I	down	8	√	
F17	GPIO3_B1/LCDC_D5_M0/CIF_D6_M1/I2S0_8CH_SDI2/SPI 1_CSNO	GPIO3_B1	LCDC_D5_M0	CIF_D6_M1	I2S0_8CH_SDI2	SPI1_CSNO	I/O	I	down	8	√	
B18	GPIO3_B2/LCDC_D6/SPI1_CSNO	GPIO3_B2	LCDC_D6	SPI1_CSNO			I/O	I	down	8	√	
C17	GPIO3_B3/LCDC_D7/I2S0_8CH_SDI1	GPIO3_B3	LCDC_D7	I2S0_8CH_SDI 1			I/O	I	down	8	√	
F18	GPIO3_B4/LCDC_D8_M0/CIF_D7_M1/I2S0_8CH_SCLKRX/S PI1_MOSI	GPIO3_B4	LCDC_D8_M0	CIF_D7_M1	I2S0_8CH_SCLKRX	SPI1_MOSI	I/O	I	down	8	√	
C16	GPIO3_B5/LCDC_D9_M0/I2S0_8CH_LRCKRX	GPIO3_B5	LCDC_D9_M0	I2S0_8CH_LRC KRX			I/O	I	down	8	√	
G18	GPIO3_B6/LCDC_D10_M0/CIF_D8_M1/I2S0_8CH_SDO3/SP I1_MISO	GPIO3_B6	LCDC_D10_M0	CIF_D8_M1	I2S0_8CH_SDO3	SPI1_MISO	I/O	I	down	8	√	VCCIO4
G17	GPIO3_B7/LCDC_D11_M0/CIF_D9_M1/I2S0_8CH_SDO2/SP I1_CLK	GPIO3_B7	LCDC_D11_M0	CIF_D9_M1	I2S0_8CH_SDO2	SPI1_CLK	I/O	I	down	8	√	
A20	GPIO3_C0/LCDC_D12/I2S0_8CH_SDO1	GPIO3_C0	LCDC_D12	I2S0_8CH_SDO 1			I/O	I	down	8	√	

Pin	Pin Name	Func1	Func2	Func3	Func4	Func5	Pad Typ e①	Def ③	Pull	Drive Streng th②	INT ④	DIE Power domain
B20	GPIO3_C1/LCDC_D13/I2S0_8CH_MCLK	GPIO3_C1	LCDC_D13	I2S0_8CH_MCLK			I/O	I	down	8	√	
C19	GPIO3_C2/LCDC_D14/I2S0_8CH_LRCKTX/TDM_FSYNC	GPIO3_C2	LCDC_D14		I2S0_8CH_LRCKTX	TDM_FSYNC	I/O	I	down	8	√	
B19	GPIO3_C3/LCDC_D15/I2S0_8CH_SCLKTX/TDM_SCLK	GPIO3_C3	LCDC_D15		I2S0_8CH_SCLKTX	TDM_SCLK	I/O	I	down	8	√	
C18	GPIO3_C4/LCDC_D16/I2S0_8CH_SDO0/TDM_SDO	GPIO3_C4	LCDC_D16		I2S0_8CH_SDO0	TDM_SDO	I/O	I	down	8	√	
A18	GPIO3_C5/LCDC_D17/I2S0_8CH_SDI0/TDM_SDI	GPIO3_C5	LCDC_D17		I2S0_8CH_SDI0	TDM_SDI	I/O	I	down	8	√	
D13	GPIO3_C6/LCDC_D18/ PDM_CLK0_M0	GPIO3_C6	LCDC_D18		PDM_CLK0_M0		I/O	I	down	8	√	
D14	GPIO3_C7/LCDC_D19 /PDM_CLK1	GPIO3_C7	LCDC_D19		PDM_CLK1		I/O	I	down	8	√	
D15	GPIO3_D0/LCDC_D20/CIF_CLKOUT_M1/PDM_SDI1	GPIO3_D0	LCDC_D20	CIF_CLKOUT_M1	PDM_SDI1		I/O	I	down	8	√	
D16	GPIO3_D1/LCDC_D21/CIF_VSYNC_M1/PDM_SDI2/ISP_PRELIGHT_TRIG	GPIO3_D1	LCDC_D21	CIF_VSYNC_M1	PDM_SDI2	ISP_PRELIGHT_TRIG	I/O	I	down	8	√	
D17	GPIO3_D2/LCDC_D22/CIF_HREF_M1/PDM_SDI3/ISP_FLASH_TRIGOUT	GPIO3_D2	LCDC_D22	CIF_HREF_M1	PDM_SDI3	ISP_FLASH_TRIGOUT	I/O	I	down	8	√	
V14	ADC_IN0	ADC_IN0					A		N/A			ADC_AVD D
W14	ADC_IN1	ADC_IN1					A		N/A			
V15	ADC_IN2	ADC_IN2					A		N/A			
T2	DDR_D_m0	DDR3_D_m0	DDR4_D_m0				A		N/A			DDRIO
U4	DDR_D_M1	DDR3_D_M1	DDR4_D_M1				A		N/A			
G4	DDR_DM2	DDR3_DM2	DDR4_DM2				A		N/A			
M4	DDR_DM3	DDR3_DM3	DDR4_DM3				A		N/A			
R4	DDR_DQ0	DDR3_DQ0	DDR4_DQ0				A		N/A			
R1	DDR_DQ1	DDR3_DQ1	DDR4_DQ1				A		N/A			
Y3	DDR_DQ10	DDR3_DQ10	DDR4_DQ10				A		N/A			
M2	DDR_DQ11	DDR3_DQ11	DDR4_DQ11				A		N/A			
V4	DDR_DQ12	DDR3_DQ12	DDR4_DQ12				A		N/A			
M3	DDR_DQ13	DDR3_DQ13	DDR4_DQ13				A		N/A			

Pin	Pin Name	Func1	Func2	Func3	Func4	Func5	Pad Typ e①	Def ③	Pull	Drive Streng th②	INT ④	DIE Power domain
V3	DDR_DQ14	DDR3_DQ14	DDR4_DQ14				A		N/A			
N4	DDR_DQ15	DDR3_DQ15	DDR4_DQ15				A		N/A			
F4	DDR_DQ16	DDR3_DQ16	DDR4_DQ16				A		N/A			
G3	DDR_DQ17	DDR3_DQ17	DDR4_DQ17				A		N/A			
F3	DDR_DQ18	DDR3_DQ18	DDR4_DQ18				A		N/A			
K2	DDR_DQ19	DDR3_DQ19	DDR4_DQ19				A		N/A			
U3	DDR_DQ2	DDR3_DQ2	DDR4_DQ2				A		N/A			
L2	DDR_DQ20	DDR3_DQ20	DDR4_DQ20				A		N/A			
M1	DDR_DQ21	DDR3_DQ21	DDR4_DQ21				A		N/A			
E2	DDR_DQ22	DDR3_DQ22	DDR4_DQ22				A		N/A			
L1	DDR_DQ23	DDR3_DQ23	DDR4_DQ23				A		N/A			
K3	DDR_DQ24	DDR3_DQ24	DDR4_DQ24				A		N/A			
J4	DDR_DQ25	DDR3_DQ25	DDR4_DQ25				A		N/A			
C2	DDR_DQ26	DDR3_DQ26	DDR4_DQ26				A		N/A			
D2	DDR_DQ27	DDR3_DQ27	DDR4_DQ27				A		N/A			
K4	DDR_DQ28	DDR3_DQ28	DDR4_DQ28				A		N/A			
J3	DDR_DQ29	DDR3_DQ29	DDR4_DQ29				A		N/A			
Y2	DDR_DQ3	DDR3_DQ3	DDR4_DQ3				A		N/A			
D1	DDR_DQ30	DDR3_DQ30	DDR4_DQ30				A		N/A			
E1	DDR_DQ31	DDR3_DQ31	DDR4_DQ31				A		N/A			
N2	DDR_DQ4	DDR3_DQ4	DDR4_DQ4				A		N/A			
R3	DDR_DQ5	DDR3_DQ5	DDR4_DQ5				A		N/A			
R2	DDR_DQ6	DDR3_DQ6	DDR4_DQ6				A		N/A			
Y1	DDR_DQ7	DDR3_DQ7	DDR4_DQ7				A		N/A			
AA2	DDR_DQ8	DDR3_DQ8	DDR4_DQ8				A		N/A			
P3	DDR_DQ9	DDR3_DQ9	DDR4_DQ9				A		N/A			
W1	DDR_DQS0_N	DDR3_DQS0_N	DDR4_DQS0_N				A		N/A			

Pin	Pin Name	Func1	Func2	Func3	Func4	Func5	Pad Typ e①	Def ③	Pull	Drive Streng th②	INT ④	DIE Power domain
W2	DDR_DQS0_P	DDR3_DQS0_P	DDR4_DQS0_P				A		N/A			
U1	DDR_DQS1_N	DDR3_DQS1_N	DDR4_DQS1_N				A		N/A			
U2	DDR_DQS1_P	DDR3_DQS1_P	DDR4_DQS1_P				A		N/A			
J1	DDR_DQS2_N	DDR3_DQS2_N	DDR4_DQS2_N				A		N/A			
J2	DDR_DQS2_P	DDR3_DQS2_P	DDR4_DQS2_P				A		N/A			
G1	DDR_DQS3_N	DDR3_DQS3_N	DDR4_DQS3_N				A		N/A			
G2	DDR_DQS3_P	DDR3_DQS3_P	DDR4_DQS3_P				A		N/A			
C7	DDR3_A0/DDR4_A10	DDR3_A0	DDR4_A10				A		N/A			
D10	DDR3_A1/DDR4_A9	DDR3_A1	DDR4_A9				A		N/A			
A10	DDR3_A10/DDR4_CS0n	DDR3_A10	DDR4_CS0n				A		N/A			
B7	DDR3_A11/DDR4_A3	DDR3_A11	DDR4_A3				A		N/A			
A9	DDR3_A12/DDR4_BA1	DDR3_A12	DDR4_BA1				A		N/A			
D6	DDR3_A13/DDR4_A2	DDR3_A13	DDR4_A2				A		N/A			
A7	DDR3_A14/DDR4_A1	DDR3_A14	DDR4_A1				A		N/A			
C9	DDR3_A15/DDR4_ODT0	DDR3_A15	DDR4_ODT0				A		N/A			
D8	DDR3_A2/DDR4_A4	DDR3_A2	DDR4_A4				A		N/A			
B5	DDR3_A3/DDR4_A6	DDR3_A3	DDR4_A6				A		N/A			
A8	DDR3_A4/DDR4_A5	DDR3_A4	DDR4_A5				A		N/A			
A4	DDR3_A5/DDR4_A8	DDR3_A5	DDR4_A8				A		N/A			
B8	DDR3_A6/DDR4_A7	DDR3_A6	DDR4_A7				A		N/A			
B4	DDR3_A7/DDR4_A11	DDR3_A7	DDR4_A11				A		N/A			
C10	DDR3_A8/DDR4_A13	DDR3_A8	DDR4_A13				A		N/A			
C6	DDR3_A9/DDR4_A0	DDR3_A9	DDR4_A0				A		N/A			
A3	DDR3_BA0/DDR4_BG0	DDR3_BA0	DDR4_BG0				A		N/A			
B10	DDR3_BA1/DDR4_CASn/DDR4_A15	DDR3_BA1	DDR4_CASn	DDR4_A15			A		N/A			
A5	DDR3_BA2/DDR4_BA0	DDR3_BA2	DDR4_BA0				A		N/A			
D9	DDR3_CASn/DDR4_A12	DDR3_CASn	DDR4_A12				A		N/A			

Pin	Pin Name	Func1	Func2	Func3	Func4	Func5	Pad Typ e①	Def ③	Pull	Drive Streng th②	INT ④	DIE Power domain
B11	DDR3_CKE/DDR4_RASn/DDR4_A16	DDR3_CKE	DDR4_RASn	DDR4_A16			A		N/A			
B1	DDR3_CLKN/DDR4_CLKN	DDR3_CLKN	DDR4_CLKN				A		N/A			
B2	DDR3_CLKP/DDR4_CLKP	DDR3_CLKP	DDR4_CLKP				A		N/A			
B3	DDR3_CSN0/DDR4_ACTn	DDR3_CSN0	DDR4_ACTn				A		N/A			
D11	DDR3_CSN1/DDR4_CS1N	DDR3_CSN1	DDR4_CS1N				A		N/A			
D5	DDR3_ODT0/DDR4_Wen/DDR4_A14	DDR3_ODT0	DDR4_Wen	DDR4_A14			A		N/A			
C11	DDR3_ODT1/DDR4_ODT1	DDR3_ODT1	DDR4_ODT1				A		N/A			
C4	DDR3_RASn/DDR4_CKE	DDR3_RASn	DDR4_CKE				A		N/A			
A2	DDR3_RESETr/DDR4_RESETrN	DDR3_RESETr	DDR4_RESETrN				A		N/A			
C8	DDR3_WEn/DDR4_BG1	DDR3_WEn	DDR4_BG1				A		N/A			
B14	LVDS_CLKN/MIPI_TX_CLKN/LCDC_D4_M1	LVDS_CLKN	MIPI_TX_CLKN	LCDC_D4_M1			A		N/A			
A14	LVDS_CLKP/MIPI_TX_CLKP/LCDC_D3_M1	LVDS_CLKP	MIPI_TX_CLKP	LCDC_D3_M1			A		N/A			
G12	LVDS_RBIASt	LVDS_RBIASt					A		N/A			
B16	LVDS_TX0N/MIPI_TX_D0N/LCDC_D11_M1	LVDS_TX0N	MIPI_TX_D0N	LCDC_D11_M1			A		N/A			
B17	LVDS_TX0P/MIPI_TX_D0P/LCDC_D8_M1	LVDS_TX0P	MIPI_TX_D0P	LCDC_D8_M1			A		N/A			
B15	LVDS_TX1N/MIPI_TX_D1N/LCDC_D1_M1	LVDS_TX1N	MIPI_TX_D1N	LCDC_D1_M1			A		N/A			
A16	LVDS_TX1P/MIPI_TX_D1P/LCDC_D10_M1	LVDS_TX1P	MIPI_TX_D1P	LCDC_D10_M1			A		N/A			
C13	LVDS_TX2N/MIPI_TX_D2N/LCDC_VSYNC_M1	LVDS_TX2N	MIPI_TX_D2N	LCDC_VSYNC_M1			A		N/A			
B13	LVDS_TX2P/MIPI_TX_D2P/LCDC_D5_M1	LVDS_TX2P	MIPI_TX_D2P	LCDC_D5_M1			A		N/A			MIPI_DSI
B12	LVDS_TX3N/MIPI_TX_D3N/LCDC_HSYNC_M1	LVDS_TX3N	MIPI_TX_D3N	LCDC_HSYNC_M1			A		N/A			
A12	LVDS_TX3P/MIPI_TX_D3P/LCDC_DEN_M1	LVDS_TX3P	MIPI_TX_D3P	LCDC_DEN_M1			A		N/A			
U10	MIPI_CSI_CLKN	MIPI_CSI_CLKN					A		N/A			
V10	MIPI_CSI_CLKP	MIPI_CSI_CLKP					A		N/A			
V11	MIPI_CSI_DNO	MIPI_CSI_DNO					A		N/A			MIPI_CSI



Pin	Pin Name	Func1	Func2	Func3	Func4	Func5	Pad Typ e①	Def ③	Pull	Drive Streng th②	INT ④	DIE Power domain
W9	MIPI_CSI_DN1	MIPI_CSI_DN1					A		N/A			
V8	MIPI_CSI_DN2	MIPI_CSI_DN2					A		N/A			
W8	MIPI_CSI_DN3	MIPI_CSI_DN3					A		N/A			
W10	MIPI_CSI_DP0	MIPI_CSI_DP0					A		N/A			
Y9	MIPI_CSI_DP1	MIPI_CSI_DP1					A		N/A			
U9	MIPI_CSI_DP2	MIPI_CSI_DP2					A		N/A			
V9	MIPI_CSI_DP3	MIPI_CSI_DP3					A		N/A			
U11	MIPI_CSI_RBIA S	MIPI_CSI_RBIA S					A		N/A			PMU_VDD
U20	OSC_24M_IN	OSC_24M_IN					A		N/A			
U21	OSC_24M_OUT	OSC_24M_OUT					A		N/A			
Y12	NC_1						A		N/A			USB
AA12	NC_2						A		N/A			
Y11	USB_ID	USB_ID					A		N/A			
AA10	USB_OTG_DM	USB_OTG_DM					A		N/A			
Y10	USB_OTG_DP	USB_OTG_DP					A		N/A			
Y13	USB_VBUS	USB_VBUS					A		N/A			

Notes:

- ① Pad types: I = digital-input, O = digital-output, I/O = digital input/output (bidirectional) , A=Analog IO
- ② Def default IO direction for digital IO
- ③ Output Drive Unit is mA, only Digital IO has drive value;
- ④ INT: interrupt support;

## 2.8 IO Pin Name Description

This sub-chapter will focus on the detailed function description of every pins based on different interface.

Table 2-4 IO function description list

Interface	Pin Name	Direction	Description
Misc	OSC_24M_IN	I	Clock input of 24MHz crystal
	OSC_24M_OUT	O	Clock output of 24MHz crystal
	NPOR	I	Chip hardware reset

Interface	Pin Name	Direction	Description
SWJ-DP	JTAG_TCK	I	JTAG interface clock input/SWD interface clock input
	JTAG_TMS	I/O	JTAG interface TMS input/SWD interface data out

Interface	Pin Name	Direction	Description
SD/MMC Host Controller	SDMMC0_CLK	O	sdmmc card clock
	SDMMC0_CMD	I/O	sdmmc card command output and response input
	SDMMC0_D[i] (i=0~3)	I/O	sdmmc card data input and output
	SDMMC0_DET	I	sdmmc card detect signal, 0 represents presence of card

Interface	Pin Name	Direction	Description
SDIO Host Controller	SDMMC1_CLK	O	sdio card clock
	SDMMC1_CMD	I/O	sdio card command output and response input
	SDMMC1_D[i] (i=0~3)	I/O	sdio card data input and output

Interface	Pin Name	Direction	Description
eMMC Interface	EMMC_CLKOUT	O	emmc card clock
	EMMC_CMD	I/O	emmc card command output and response input
	EMMC_D[i] (i=0~7)	I/O	emmc card data input and output

Interface	Pin Name	Direction	Description
Nand Flash Interface	FLASH_ALE	O	Flash address latch enable signal
	FLASH_CLE	O	Flash command latch enable signal
	FLASH_WRN	O	Flash write enable and clock signal
	FLASH_RDN	O	Flash read enable and write/read signal
	FLASH_Di(i=0~7)	I/O	Flash data inputs/outputs signal
	FLASHx_DQS	I/O	Flash data strobe signal
	FLASHx_RDY	I	Flash ready/busy signal

	FLASHx_CSN <i>i</i> ( <i>i</i> =0~1)	O	Flash chip enable signal for chip <i>i</i> , <i>i</i> =0~7
--	--------------------------------------	---	--

Interface	Pin Name	Direction	Description
SFC Controller	SFC_CLK	I/O	sfc serial clock
	SFC_CSN <i>x</i> ( <i>x</i> =0)	I/O	sfc chip select signal,low active
	SFC_SIO <i>x</i> ( <i>x</i> =0,3)	O	sfc serial data output

Interface	Pin Name	Direction	Description
LCDC	LCDC_DCLK	O	LCDC RGB interface display clock out, MCU i80 interface RS signal
	LCDC_VSYNC	O	LCDC RGB interface vertical sync pulse, MCU i80 interface CSN signal
	LCDC_HSYNC	O	LCDC RGB interface horizontal sync pulse, MCU i80 interface WEN signal
	LCDC_DEN	O	LCDC RGB interface data enable, MCU i80 interface REN signal
	LCDC_D <i>i</i> ( <i>i</i> =0~23)	O	LCDC data output/input

Interface	Pin Name	Direction	Description
DDR Interface	CLKP	O	Active-high clock signal to the memory device.
	CLKN	O	Active-low clock signal to the memory device.
	CKE	O	Active-high clock enable signal to the memory device
	CSN <i>i</i> ( <i>i</i> =0,1)	O	Active-low chip select signal to the memory device. AThere are two chip select.
	RASn	O	Active-low row address strobe to the memory device.
	CASn	O	Active-low column address strobe to the memory device.
	WEn	O	Active-low write enable strobe to the memory device.
	BA <i>i</i> ( <i>i</i> =0,1,2)	O	Bank address signal to the memory device.
	A <i>i</i> ( <i>i</i> =0~15)	O	Address signal to the memory device.
	DQ <i>i</i> ( <i>i</i> =0~31)	I/O	Bidirectional data line to the memory device.
	DQS[ <i>i</i> ] <sub>P</sub> ( <i>i</i> =0~3)	I/O	Active-high bidirectional data strobes to the memory device.
	DQS[ <i>i</i> ] <sub>N</sub> ( <i>i</i> =0~3)	I/O	Active-low bidirectional data strobes to the memory device.
	DM <i>i</i> ( <i>i</i> =0~3)	O	Active-low data mask signal to the memory device.
	ODT <i>i</i> ( <i>i</i> =0,1)	O	On-Die Termination output signal for two chip select.
RESETn	O	DDR3/DDR4 reset signal to the memory device	

Interface	Pin Name	Direction	Description
I2S0/PCM Controller	I2S0_8CH_MCLK	O	I2S/PCM clock source
	I2S0_8CH_SCLK	I/O	I2S/PCM serial clock
	I2S0_8CH_LRCKRX	I/O	I2S/PCM left & right channel signal for receiving serial data, synchronous left & right channel in I2S mode and the beginning of a group of left & right channels in PCM mode
	I2S0_8CH_LRCKTX	I/O	I2S/PCM left & right channel signal for transmitting serial data, synchronous left & right channel in I2S mode and the beginning of a group of left & right channels in PCM mode
	I2S0_8CH_SDI <sub>i</sub> (i=1~3)	I	I2S/PCM serial data input
	I2S0_8CH_SDO <sub>i</sub> (i=1~3)	O	I2S/PCM serial data output

Interface	Pin Name	Direction	Description
I2S1/PCM Controller	I2S1_2CH_MCLK	O	I2S/PCM clock source
	I2S1_2CH_SCLK	I/O	I2S/PCM serial clock
	I2S1_2CH_LRCKRX	I/O	I2S/PCM left & right channel signal for receiving serial data, synchronous left & right channel in I2S mode and the beginning of a group of left & right channels in PCM mode
	I2S1_2CH_LRCKTX	I/O	I2S/PCM left & right channel signal for transmitting serial data, synchronous left & right channel in I2S mode and the beginning of a group of left & right channels in PCM mode
	I2S1_2CH_SDI	I	I2S/PCM serial data input
	I2S1_2CH_SDO	O	I2S/PCM serial data output

Interface	Pin Name	Direction	Description
I2S2/PCM Controller	I2S2_2CH_MCLK	O	I2S/PCM clock source
	I2S2_2CH_SCLK	I/O	I2S/PCM serial clock
	I2S2_2CH_LRCKRX	I/O	I2S/PCM left & right channel signal for receiving serial data, synchronous left & right channel in I2S mode and the beginning of a group of left & right channels in PCM mode
	I2S2_2CH_LRCKTX	I/O	I2S/PCM left & right channel signal for transmitting serial data, synchronous left & right channel in I2S mode and the beginning of a group of left & right channels in PCM mode
	I2S2_2CH_SDI	I	I2S/PCM serial data input
	I2S2_2CH_SDO	O	I2S/PCM serial data output

Interface	Pin Name	Direction	Description
PDM	PDM_CLK	O	PDM sampling clock
	PDM_SDI <sub>[i]</sub> (i=0~3)	I	PDM data

Interface	Pin Name	Direction	Description
TDM	TDM_SCLK	I/O	TDM serial clock
	TDM_FSYNC	I/O	TDM frame synchronization pulse
	TDM_SDI	I	TDM serial data input
	TDM_SDO	O	TDM data output

Interface	Pin Name	Direction	Description
SPI0	SPI0_CLK	I/O	SPI serial clock
	SPI0_CSN[i](i=0)	I/O	SPI chip select signal, low active
	SPI0_TXD	O	SPI serial data output
	SPI0_RXD	I	SPI serial data input

Interface	Pin Name	Direction	Description
SPI1	SPI1_CLK	I/O	SPI serial clock
	SPI1_CSN[i](i=0,1)	I/O	SPI chip select signal, low active
	SPI1_TXD	O	SPI serial data output
	SPI1_RXD	I	SPI serial data input

Interface	Pin Name	Direction	Description
PWM	PWM0	I/O	Pulse Width Modulation input and output
	PWM1	I/O	Pulse Width Modulation input and output, used for VOP CABAC PWM control

Interface	Pin Name	Direction	Description
I2C	I2C[i]_SDA (i=0,1,2)	I/O	I2C data
	I2C[i]_SCL (i=0,1,2)	I/O	I2C clock

Interface	Pin Name	Direction	Description
UART	UART[i]_RX (i=1,2)	I	UART serial data input
	UART[i]_TX (i=1,2)	O	UART serial data output
	UART[i]_CTS (i=1)	I	UART clear to send modem status input
	UART[i]_RTS (i=1)	O	UART modem control request to send output

Interface	Pin Name	Direction	Description
USB 2.0	USB_OTG_DP	I/O	USB 2.0 Data signal DP
	USB_OTG_DM	I/O	USB 2.0 Data signal DM
	USB_RBIAS	O	Connect 133 ohm resistor to ground to generate reference current
	USB_VBUS	I	Insert detect when act as USB device
	USB_ID	I	USB Mini-Receptacle Identifier

Interface	Pin Name	Direction	Description
MIPI_DSI	MIPI_TX_DiN( $i=0\sim3$ )	O	MIPI DSI negative differential data line transceiver output
	MIPI_TX_DiP( $i=0\sim3$ )	O	MIPI DSI positive differential data line transceiver output
	MIPI_TX_CLKP	O	MIPI DSI positive differential clock line transceiver output
	MIPI_TX_CLKN	O	MIPI DSI negative differential clock line transceiver output

Interface	Pin Name	Direction	Description
LVDS	LVDS_TXiN( $i=0\sim3$ )	O	LVDS negative differential data line transceiver output
	LVDS_TXiP( $i=0\sim3$ )	O	LVDS positive differential data line transceiver output
	LVDS_CLKP	O	LVDS positive differential clock line transceiver output
	LVDS_CLKN	O	LVDS negative differential clock line transceiver output
	LVDS_RBIAS	O	LVDS external resistor connection, connect 2K ohm resistor to ground

Interface	Pin Name	Direction	Description
MIPI_CSI	MIPI_CSI_DNi( $i=0\sim3$ )	I	MIPI CSI negative differential data line transceiver output
	MIPI_CSI_DPi( $i=0\sim3$ )	I	MIPI CSI positive differential data line transceiver output
	MIPI_CSI_CLKP	I	MIPI CSI positive differential clock line transceiver output
	MIPI_CSI_CLKN	I	MIPI CSI negative differential clock line transceiver output
	MIPI_CSI_RBIAS	I	MIPI CSI external resistor connection, connect 2K ohm resistor to ground

## Chapter 3 Electrical Specification

### 3.1 Absolute Ratings

The below table provides the absolute ratings.

Absolute maximum ratings specify the values beyond which the device may be damaged permanently. Long-term exposure to absolute maximum ratings conditions may affect device reliability.

Absolute minimum ratings specify the values beyond which the device may be damaged permanently. Long-term exposure to absolute minimum ratings conditions may affect device reliability.

Table 3-1 Absolute ratings

Parameters	Related Power Group	Min	Max	Unit
Supply voltage for CPU	VDD_CORE	-0.3	1.40	V
Supply voltage for GPU and core logic	VDD_LOGIC	-0.3	1.15	V
1.0V supply voltage		-0.3	1.15	V
1.8V supply voltage		-0.3	1.98	V
3.3V supply voltage		-0.3	3.63	V
Supply voltage for DDR IO		-0.3	1.65	V
Storage Temperature	Tstg	TBD	125	°C
Max Conjunction Temperature	Tj	TBD	125	°C

### 3.2 Recommended Operating Condition

Following table describes the recommended operating condition.

Table 3-2 Recommended operating condition

Parameters	Symbol	Min	Typ	Max	Unit
Voltage for CPU	CPU_VDD	0.95	1.00	1.35	V
Voltage for GPU and core logic	LOGIC_VDD	0.90	1.00	1.10	V
Voltage for PMU	PMU_VDD_1V0	0.90	1.00	1.10	V
Digital GPIO Power (3.3V/1.8V)	VCCIO1, VCCIO2, VCCIO3, VCCIO4, VCCIO5, VCCIO6, PMUIO1, PMUIO2	2.97 1.62	3.30 1.8	3.63 1.98	V
DDR3 IO power	DDR_VDD	1.425	1.5	1.575	V
DDR3L IO Power	DDR_VDD	1.283	1.35	1.417	V
LPDDR3 IO Power	DDR_VDD	1.14	1.2	1.3	V
DDR4 IO Power	DDR_VDD	1.14	1.2	1.3	V
OTP Analog Power	OTP_VCC_1V8	1.62	1.8	1.98	V
PLL Analog Power(1.0V)	PLL_DVDD_1V0	0.9	1.0	1.1	V
PLL Analog Power(1.8V)	PLL_AVDD_1V8	1.62	1.8	1.98	V
SARADC Analog Power	ADC_AVDD_1V8	1.62	1.8	1.98	V
USB 2.0 OTG/Host Analog Power (1.0V)	USB20_DVDD_1V0	0.90	1.00	1.10	V
USB 2.0 OTG/Host Analog Power (1.8V)	USB20_AVDD_1V8	1.62	1.8	1.98	V
USB 2.0 OTG/Host Analog Power (3.3V)	USB20_AVDD_3V3	2.97	3.3	3.63	V
MIPI DSI Analog Power(1.0V)	MIPI_DSI_VCCA_1V0	0.90	1.00	1.10	V
MIPI DSI Analog Power (1.8V)	MIPI_DSI_VCCA_1V8	1.62	1.8	1.98	V
MIPI DSI Analog Power (3.3V)	MIPI_DSI_VCCA_3V3	2.97	3.3	3.63	V

Parameters	Symbol	Min	Typ	Max	Unit
MIPI CSI Analog Power(1.0V)	MIPI_CSI_VCCA_1V0	0.9	1.0	1.1	V
OSC input clock frequency		N/A	24	N/A	MHz
Max CPU frequency of A35		N/A	N/A	TBD	GHz
Max GPU frequency		N/A	N/A	TBD	MHz
Ambient Operating Temperature	T <sub>A</sub>	0	25	80	°C

Notes:

- ① Symbol name is same as the pin name in the io descriptions

### 3.3 DC Characteristics

Table 3-3 DC Characteristics

Parameters		Symbol	Min	Typ	Max	Unit
Digital GPIO @3.3V	Input Low Voltage	Vil	-0.3	0	3.3x0.3	V
	Input High Voltage	Vih	3.3x0.7	3.3	3.3+0.3	V
	Output Low Voltage	Vol	NA	NA	0.4	V
	Output High Voltage	Voh	3.3-0.4	NA	NA	V
	Threshold Point	Vtr+	1.53	1.46	1.43	V
		Vtr-	1.19	1.12	1.05	V
	Pullup Resistor	Rpu	33.7	58	101.5	Kohm
Pulldown Resistor	Rpd	34.2	60.1	109.3	Kohm	
Digital GPIO @1.8V	Input Low Voltage	Vil	-0.3	0	1.8x0.3	V
	Input High Voltage	Vih	1.8x0.7	1.8	1.8 + 0.3	V
	Output Low Voltage	Vol	NA	NA	0.4	V
	Output High Voltage	Voh	1.8-0.4	NA	NA	V
	Threshold Point	Vtr+	1.23	1.12	1.03	V
		Vtr-	0.91	0.82	0.73	V
	Pullup Resistor	Rpu	35	62.9	120	Kohm
Pulldown Resistor	Rpd	35.1	61	113.9	Kohm	

Parameters		Symbol	Min	Typ	Max	Unit
DDR IO @ LPDDR2 mode	Input High Voltage	Vih_dds	VREF + 0.13	NA	DDR_VDD	V
	Input Low Voltage	Vil_dds	VSS	NA	VREF - 0.13	V
	Output High Voltage	Voh_dds	VREF + 0.13	NA	DDR_VDD	V
	Output Low Voltage	Vol_dds	VSS	NA	Vref-0.13	V
DDR IO @ LPDDR3 mode	Input High Voltage	Vih_dds	VREF + 0.1	NA	DDR_VDD	V
	Input Low Voltage	Vil_dds	VSS	NA	VREF - 0.1	V
	Output High Voltage	Voh_dds	VREF + 0.1	NA	DDR_VDD	V
	Output Low Voltage	Vol_dds	VSS	NA	VREF - 0.1	V
DDR IO @DDR3 mode	Input High Voltage	Vih_dds	VREF + 0.10	NA	DDR_VDD	V
	Input Low Voltage	Vil_dds	VSS	NA	VREF - 0.10	V
	Output High Voltage	Voh_dds	VREF + 0.10	NA	DDR_VDD	V
	Output Low Voltage	Vol_dds	VSS	NA	VREF - 0.10	V
	On die termination (ODT) resistance	Rtt	10	75	220	Ohm



Parameters		Symbol	Min	Typ	Max	Unit
DDR IO @DDR4 mode	Input High Voltage	Vih_dds	VREF +0.075	NA	DDR_VDD	V
	Input Low Voltage	Vil_dds	VSS	NA	VREF -0.075	V
	Output High Voltage	Voh_dds	VREF +0.075	NA	DDR_VDD	V
	Output Low Voltage	Vol_dds	VSS	NA	Vref-0.075	V

Parameters		Symbol	Min	Typ	Max	Unit
MIPI_DSI IO@LVDS mode	Output High Voltage	Voh	1050	NA	NA	mV
	Output Low Voltage	Vol	NA	NA	750	mV
	Output differential voltage	VOD	250	NA	400	mV
	Output offset voltage	Vos	825	NA	975	mV
	Output impedance, single ended	Ro	40	NA	140	Ω
	Ro mismatch between A & B	ΔRo	NA	NA	10	%
	Change in  Vod  between 0 and 1	ΔVod	NA	NA	25	mV
	Change in Vod between 0 and 1	ΔVos	NA	NA	25	mV
MIPI_DSI IO@TTL mode	Output High Voltage	Voh	1.8	NA	NA	V
	Output Low Voltage	Vol	NA	NA	0	V
	Short-Circuit Output Current	Ios	NA	35	60	mA
	Output impedance	Zolp	40	NA	460	Ω
MIPI_DSI IO@MIPI mode	Output High Voltage	Voh	300	NA	NA	mV
	Output Low Voltage	Vol	NA	NA	100	mV
	HS TX static Common-mode voltage	VCMTX	150	200	250	mV
	VCMTX mismatch when output is Differential-1 or Differential-0	ΔVCMTX(1,0)	NA	NA	5	mV
	HS transmit differential voltage	VOD	140	200	270	mV
	VOD mismatch when output is Differential-1 or Differential-0	ΔVOD	NA	NA	10	mV
	HS output high voltage	VOHHS	NA	NA	360	mV
	Single ended output impedance	ZOS	40	50	62.5	Ω
	Single ended output impedance mismatch	ΔZOS	NA	NA	10	%

### 3.4 Electrical Characteristics for General IO

Table 3-4 Electrical Characteristics for Digital General IO

Parameters		Symbol	Test condition	Min	Typ	Max	Unit
Digital GPIO @3.3V	Input leakage current	Ii	Vin = 3.3V or 0V	NA	NA	10	uA
	Tri-state output leakage current	Ioz	Vout = 3.3V or 0V	NA	NA	10	uA

Parameters		Symbol	Test condition	Min	Typ	Max	Unit
	High level input current	Iih	Vin = 3.3V, pulldown disabled	NA	NA	10	uA
			Vin = 3.3V, pulldown enabled	NA	NA	106.4	uA
	Low level input current	Iil	Vin = 0V, pullup disabled	NA	NA	10	uA
			Vin = 0V, pullup enabled	NA	NA	107.8	uA
Digital GPIO @1.8V	Input leakage current	Ii	Vin = 1.8V or 0V	NA	NA	10	uA
	Tri-state output leakage current	Ioz	Vout = 1.8V or 0V	NA	NA	10	uA
	High level input current	Iih	Vin = 1.8V, pulldown disabled	NA	NA	10	uA
			Vin = 1.8V, pulldown enabled	NA	NA	61.3	uA
	Low level input current	Iil	Vin = 0V, pullup disabled	NA	NA	10	uA
			Vin = 0V, pullup enabled	NA	NA	61.4	uA

### 3.5 Electrical Characteristics for PLL

Table 3-5 Electrical Characteristics for PLL

Parameters		Symbol	Test condition	Min	Typ	Max	Unit
PLL	Input clock frequency(Int)	F <sub>in</sub>	Fin = FREF @3.3V/1.1V	1		800	MHz
	Input clock frequency(Frac)	F <sub>in</sub>	Fin = FREF @3.3V/1.1V	10		800	MHz
	VCO operating range	F <sub>vco</sub>	Fvco = Fref * FBDIV @3.3V/1.1V	800		3200	MHz
	Output clock frequency	F <sub>out</sub>	Fout = Fvco/POSTDIV @3.3V/1.1V	16		3200	MHz
	Lock time	T <sub>lt</sub>	@ 3.3V/1.1V, FREF=24M,REFDIV=1		250	500	Input clock cycles
	VDDHV current consumption		Fvco = 1000MHz, @3.3V Current scale as (Fvco/1GHz) <sup>1.5</sup>		1.0	1.2	mA
	VDD Current consumption		VDD = 1.1V		1.3	1.56	uA/MHz
	Power consumption (power-down mode)		PD=HIGH, @27 °C		13		uA

Notes:

- ① REFDIV is the input divider value;

② FBDIV is the feedback divider value;

③ POSTDIV is the output divider value

### 3.6 Electrical Characteristics for USB 2.0 Interface

Table 3-6 Electrical Characteristics for USB 2.0 Interface

Parameters	Symbol	Test condition	Min	Typ	Max	Unit
Transmitter						
High input level	VIH		NA	1.0	NA	V
Low input level	VIL		NA	0	NA	V
Output resistance	ROUT	Classic mode (Vout = 0 or 3.3V)	40.5	45	49.5	ohms
		HS mode (Vout = 0 to 800mV)	40.5	45	49.5	ohms
Output Capacitance	COUT	seen from D+ or D-			3	pF
Output Common Mode Voltage	VM	Classic (LS/FS) mode	1.45	1.65	1.85	V
		HS mode	0.175	0.2	0.225	V
Differential output signal high	VOH	Classic (LS/FS); Io=0mA	2.97	3.3	3.63	V
		Classic (LS/FS); Io=6mA	2.2	NA	NA	V
		HS mode; Io=0mA	360	400	440	mV
Differential output signal low	VOL	Classic (LS/FS); Io=0mA	-0.33	0	0.33	V
		Classic (LS/FS); Io=6mA	NA	0.3	0.8	V
		HS mode; Io=0mA	-40	0	40	mV
Receiver						
Receiver sensitivity	RSENS	Classic mode		+ -250		mV
		HS mode		+ -25		mV
Receiver common mode	RCM	Classic mode	0.8	1.65	2.5	V
		HS mode (differential and squelch comparator)	0.1	0.2	0.3	V
		HS mode (disconnect comparator)	0.5	0.6	0.7	V
Input capacitance (seen at D+ or D-)			NA	NA	3	pF
Squelch threshold			100	112	150	mV
Disconnect threshold			570	590	625	mV
High output level	VOH		NA	3.3	NA	V
Low output level	VOL		NA	0	NA	V

### 3.7 Electrical Characteristics for DDR IO

Table 3-7 Electrical Characteristics for DDR IO

Parameters	Symbol	Test condition	Min	Typ	Max	Unit
DDR IO @DDR3 mode	Input leakage current, SSTL mode, unterminated	@ 1.5V , 125°C	NA	0		uA
DDR IO @DDR3L mode	Input leakage current	@ 1.35V , 125°C	NA	0	NA	nA

Parameters		Symbol	Test condition	Min	Typ	Max	Unit
DDR IO @LPDDR2/LPDDR3 mode	Input leakage current		@ 1.2V , 125°C	NA	0	0.49	nA
DDR IO @DDR4 mode	Input leakage current		@ 1.2V , 125°C	-5	0	+5	uA

### 3.8 Electrical Characteristics for TSADC

Table 3-8 Electrical Characteristics for TSADC

Parameters	Symbol	Test condition	Min	Typ	Max	Unit
Temperature Resolution				5		°C
Temperature Range			-10		120	°C
Analog power	IAVDD	Fs= 50KS/s		190		uA
Digital power	IVDD	Fs= 50KS/s		10		uA
Clock Frequency	Fclk	Fclk			50	KHz
Power Down Current from Analog	IAVDD	Power down		1		uA
Power Down Current from Digital	IVDD	Power down		1		uA

### 3.9 Electrical Characteristics for MIPI DSI

Table 3-9 Electrical Characteristics for MIPI DSI

Parameters	Symbol	Test condition	Min	Typ	Max	Units
HS TX static common-mode	Vcmtx		150	200	250	mV
Vcmtx mismatch when output is Differential-1 or Differential-0	$\Delta V_{cmtx}(1,0)$				5	mV
HS Transmit differential voltage	Vod		140	200	270	mV
Vod mismatch when output is Differential-1 or Differential-0	$\Delta V_{od}$				10	mV
HS output high voltage	Vohhs				360	mV
Single ended output impedance	Zos		40	50	62.5	Ohm
Single ended output impedance mismatch	$\Delta Z_{os}$				10	%
The venin output high level	Voh		0.9	1	1.1	V
The venin output low level	Vol		-50		50	mV
Output impedance of LP	Zolp		110			$\Omega$
High-level output voltage	Voh		3	3.3		V
Low-level output voltage	Vol			0	0.2	V
Output impedance	Zolp		40		460	$\Omega$
Common-mode variations above 450 MHz	$\Delta V_{cmtx}(HF)$				15	mVrms
Common-mode variations between 50MHz - 450MHz	$\Delta V_{cmtx}(LF)$					mVpeak

Parameters	Symbol	Test condition	Min	Typ	Max	Units
20%-80% rise time and fall time	Tr and Tf				0.3	UI
			150			ps
Maximum data rate	Dmax			200		Mbit/s
15%-85% rise time and fall time	Trlp/Tflp		1	1.5	2	ns
Slew rate, transition region	SR		20	27	30	V/ns

### 3.10 Electrical Characteristics for MIPI CSI

Table 3-10 Electrical Characteristics for MIPI CSI

Parameters	Symbol	Test condition	Min	Typ	Max	Units
Common-mode voltage HS receive mode	Vcmrx(dc)		70		300	mV
Differential input high threshold	Vidth				70	mV
Differential input low threshold	Vidtl		-70			mV
Single-ended input high voltage	Vihhs				460	mV
Single-ended input low voltage	Vilhs		-40			mV
Single-ended threshold for HS termination enable	Vterm-en				450	mV
Differential input impedance	Zid		80	100	125	$\Omega$
Logic 1 input voltage	Vih		880			mV
Logic 0 input voltage, not in ULP state	Vil				550	mV
Logic 0 input voltage, ULP state	Vil-ulps				300	mV
Input hysteresis	Vhyst		25			mV
Common-mode interference beyond 450 MHz	$\Delta V_{cmrx}(HF)$				100	mV
Common-mode interference 50MHz-450MHz	$\Delta V_{cmrx}(LF)$		-50		50	mV
Common-mode termination	Ccm				60	pF
Input pulse rejection	Espike				300	V.ps
Minimum pulse width response	Tmin-rx		20			ns
Peak interference amplitude	Vint				200	mV
Interference frequency	Fint		450			MHz

## Chapter 4 Thermal Management

### 4.1 Overview

For reliability and operability concerns, the absolute maximum junction temperature has to be below 125°C.

### 4.2 Package Thermal Characteristics

Table 4-1 provides the thermal resistance characteristics for the package used on the SoC. The resulting simulation data for reference only, please prevail in kind test.

Table 4-1 Thermal Resistance Characteristics

Parameter	Symbol	Typical	Unit
Junction-to-ambient thermal resistance	$\theta_{JA}$	26.9	(°C/W)
Junction-to-board thermal resistance	$\theta_{JB}$	NA	(°C/W)
Junction-to-case thermal resistance	$\theta_{JC}$	8.2	(°C/W)

Note: The testing PCB is 4 layers, 114.3mmx101.5mm, 1.6mm thickness, Ambient temperature is 25°C.