

Low Noise, Low Power Precision Voltage Reference

Features

- Low noise (0.1 Hz to 10 Hz): 2.5 ppm_{peak-peak}
- Low temperature coefficient: 5 ppm/°C max
- Initial accuracy: ±0.05 % max
- Quiescent current: 130 μA
Shutdown current: 3 μA
- Supply voltage: $V_{OUT} + 0.3 \text{ V}$ to 5.5 V
- Line regulation: 10 ppm/V max
- Load regulation: 10 ppm/mA max
- Small package: SOT23-6
- Temperature range: -40 °C to +125 °C
- ZJR1001 has noise filter option
- Pin compatible with industry standard products
- **Fully AEC-Q100 qualified**

Applications

- Industrial control
- Precision data acquisition
- Optical Communication
- Precision instrument
- Smart grid
- Medical equipment
- Portable Devices

General Description

The ZJR1001 and ZJR1002 offer a low noise, low power and low-drift voltage reference in a small 6-pin SOT23 package. They are suitable for data acquisition applications with high resolution (14-bit or more), such as precision instruments and test equipment. Because of the low dropout feature, ZJR1001 and ZJR1002's input voltage can start from 300 mV higher than the output voltage, which can simplify the system power supply design. The supply current is just 130 μA, making them suitable for portable devices while maintaining high performances. By optimized design and proprietary trimming, ZJR1001 and ZJR1002 achieve the temperature coefficient within 5 ppm/°C and initial accuracy within ±0.05%. This simplifies or even allows the user to skip system calibration for most applications. ZJR1001 offers noise filter option for wideband applications, and ZJR1002 can enable the output in Kelvin connection.

The ZJR1001 and ZJR1002 are available in a 6-lead SOT23 package and are specified over the extended industrial temperature range of -40 °C to +125 °C.

Typical Application

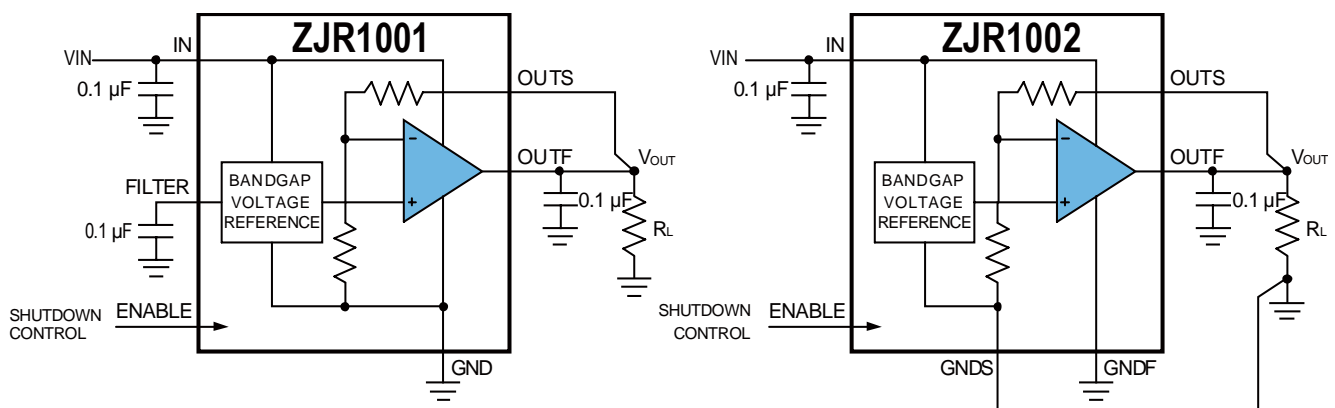

Table of contents

Features	1	Applications.....	13
Applications	1	ZJR1001, ZJR1002 Basic Connections.....	13
General Description.....	1	Power on and Shutdown Mode	13
Typical Application	1	Supply Voltage	14
Table of contents	2	Noise Performance.....	14
Version (Release B)	3	Power Dissipation.....	14
Revision History	3	Product Applications.....	15
Pin Configurations and Function Descriptions.....	4	Voltage Reference Noise to ADC Resolution	15
Absolute Maximum Ratings	5	Using ZJR1002 and ZJC2542 to Build up to 18-bit Signal	
Thermal Resistance	5	Sources	15
Specifications	6	Layout Guidelines	17
Typical Performance Characteristics	7	Layout Example.....	17
Terminology	11	Outline Dimensions.....	19
Temperature Coefficient.....	11	Ordering Guide.....	20
Long-term Stability	11	Orderable Device Explanation	20
Thermal Hysteresis	11	Related Device.....	21
Line Regulation	11		
Load Regulation.....	11		
Theory of Operation.....	12		

Version (Release C) ¹

Revision History

April 2024 — Release C

Long-Term Stability updating at page 6

Add Figure 22 at page 10

January 2024 — Release B

Add AEC-Q100 qualification at page 1

May 2023 — Release A

¹ Information furnished by ZJW Microelectronics is believed to be accurate and reliable. However, no responsibility is assumed by ZJW Microelectronics for its use, nor for any infringements of patents or other rights of third parties that may result from its use. Specifications subject to change without notice. No license is granted by implication or otherwise under any patent or patent rights of ZJW Microelectronics. Trademarks and registered trademarks are the property of their respective owners.

Pin Configurations and Function Descriptions

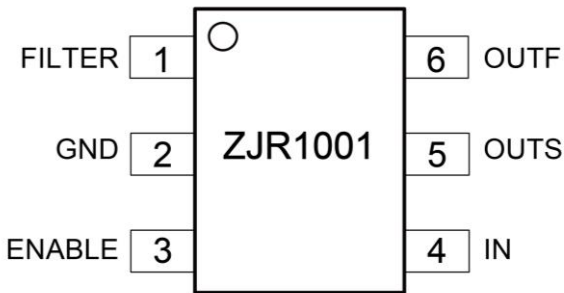

Figure 1. ZJR1001 Pin Configuration (6-lead SOT23)

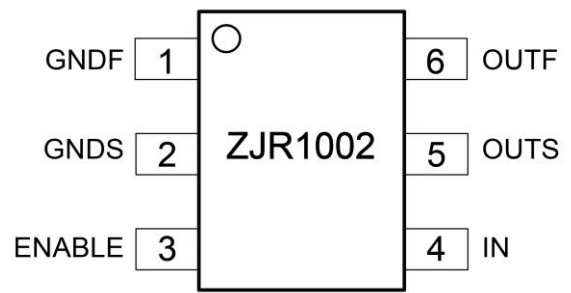

Figure 2. ZJR1002 Pin Configuration (6-lead SOT23)

Mnemonic	Pin No.	Description
FILTER	1	Filter Input. Connect a 0.1 μ F capacitor from FILTER to ground to provide high-frequency bypass. Leave unconnected, if not used.
GND	2	Ground
ENABLE	3	Enable. Drive high to enable the device. Drive low to disable the device.
IN	4	Supply voltage input
OUTS	5	Voltage Reference Sense Output
OUTF	6	Voltage Reference Force Output. Short OUTF to OUTS as close as possible to the load. Bypass OUTF with a capacitor (0.1 μ F to 10 μ F) to GND.

Mnemonic	Pin No.	Description
GNDF	1	Ground Force
GNDS	2	Ground Sense. Connect to ground connection at the load.
ENABLE	3	Enable. Drive high to enable the device. Drive low to disable the device.
IN	4	Supply voltage input
OUTS	5	Voltage Reference Sense Output
OUTF	6	Voltage Reference Force Output. Short OUTF to OUTS as close as possible to the load. Bypass OUTF with a capacitor (0.1 μ F to 10 μ F) to GND.

Absolute Maximum Ratings ¹

Parameter	Rating
Input Voltage	-0.2 V to 6 V
Output Short-Circuit Current to GND	±30 mA
Operating Temperature Range	-40 °C to +125 °C
Storage Temperature Range	-65 °C to +150 °C
Junction Temperature Range	-65 °C to +150 °C
Maximum Reflow Temperature ²	260 °C
Lead Temperature (Soldering, 10 sec)	300 °C
Electrostatic Discharge (ESD) ¹	
Human Body Model (HBM) ²	8 kV
Charging Device Model (CDM) ³	1 kV

Thermal Resistance ⁶

Package Type	θ_{JA}	θ_{JC}	Unit
SOT23	230	76	°C/W

¹ These ratings apply at 25 °C, unless otherwise noted. Stresses above these ratings may cause permanent damage. Exposure to absolute maximum conditions for extended periods may degrade device reliability. These are stress ratings only, and functional operation of the device at these or any other conditions beyond those specified is not implied.

² IPC/JEDECJ–STD-020 Compliant.

¹ Charged devices and circuit boards can discharge without detection.

Although this product features patented or proprietary protection circuitry, damage may occur on devices subjected to high energy ESD. Therefore, proper ESD precautions should be taken to avoid performance degradation or loss of functionality.

² ANSI/ESDA/JEDEC JS-001 Compliant.

³ ANSI / ESDA / JEDEC JS-002 Compliant

⁶ θ_{JA} addresses the conditions for soldering devices onto circuit boards to achieve surface mount packaging.

Specifications ¹

The “•” denotes the specification which apply over the full specified temperature range, unless otherwise specified, $V_{IN} = V_{OUT} + 0.3V$, $I_{LOAD} = 0$, $C_L = 0.1 \mu F$, $T_A = 25 \text{ }^\circ\text{C}$.

Parameter	Symbol	Conditions/Package	Min	Typ	Max	Unit
Output Voltage	V_{OUT}	ZJR1001/1002-9		2.5		V
		ZJR1001/1002-3		3		V
		ZJR1001/1002-4		4.096		V
		ZJR1001/1002-5		5		V
Initial Accuracy			-0.05		+ 0.05	%
Temperature Coefficient	TCV_{OUT}					
B Grade		•			5	ppm / $^\circ\text{C}$
A Grade		•			8	ppm / $^\circ\text{C}$
Voltage Noise	e_n p-p	0.1 Hz to 10 Hz		2.5		ppm_peak-to-peak
Voltage Noise Density	e_n	ZJR1001-9, $C_{FILTER} = 0.1 \mu F$, $f = 1 \text{ kHz}$		60		$\text{nV}/\sqrt{\text{Hz}}$
		ZJR1002-9, $f = 1 \text{ kHz}$		200		$\text{nV}/\sqrt{\text{Hz}}$
		ZJR1001-3, $C_{FILTER} = 0.1 \mu F$, $f = 1 \text{ kHz}$		92		$\text{nV}/\sqrt{\text{Hz}}$
		ZJR1002-3, $f = 1 \text{ kHz}$		250		$\text{nV}/\sqrt{\text{Hz}}$
		ZJR1001-4, $C_{FILTER} = 0.1 \mu F$, $f = 1 \text{ kHz}$		85		$\text{nV}/\sqrt{\text{Hz}}$
		ZJR1002-4, $f = 1 \text{ kHz}$		320		$\text{nV}/\sqrt{\text{Hz}}$
		ZJR1001-5, $C_{FILTER} = 0.1 \mu F$, $f = 1 \text{ kHz}$		108		$\text{nV}/\sqrt{\text{Hz}}$
		ZJR1002-5, $f = 1 \text{ kHz}$		308		$\text{nV}/\sqrt{\text{Hz}}$
Line Regulation			•	2 5	10	ppm/V ppm/V
Load Regulation		$-10 \text{ mA} < I_{LOAD} < 10 \text{ mA}$	•	1.5 6	10	ppm/mA ppm/mA
Supply Voltage		$I_{LOAD} = 5 \text{ mA}$, output voltage error $< 0.1\%$	$V_{OUT} + 0.3$		5.5	V
Supply Current	I_Q		•	130		μA
Shutdown Current			•	3		μA
Dropout Voltage		$I_{LOAD} = 0$	•	5		mV
		$I_{LOAD} = 5 \text{ mA}$	•	50		mV
Enable Pin (ENABLE)		Input Current	•	- 1	1	μA
		Logic High Voltage	•	2		V
		Logic Low Voltage	•		0.8	V
Short-Circuit Current	I_L	$V_{OUT} = \text{GND}/V_{IN}$		16	20	mA
Ripple Rejection Ratio		Frequency = 60 Hz			- 95	dB
Turn-on Settling Time		Stable to 0.1 %, $C_L = 0.1 \mu F$			220	μs
Long-Term Stability ²		1000 hours, SOT23-6			-30	ppm / 1000 hours
Temperature Range		Specified Temperature Range		- 40	125	$^\circ\text{C}$
		Operating Temperature Range		- 55	125	$^\circ\text{C}$

¹ Each parameter is explained in the terminology section of this data sheet.

² Data collected using devices soldered onto the test board.

Typical Performance Characteristics

Unless otherwise stated, $V_{IN} = V_{OUT} + 0.3\text{ V}$, $I_{LOAD} = 0$, $C_L = 0.1\ \mu\text{F}$, $T_A = 25\ ^\circ\text{C}$.

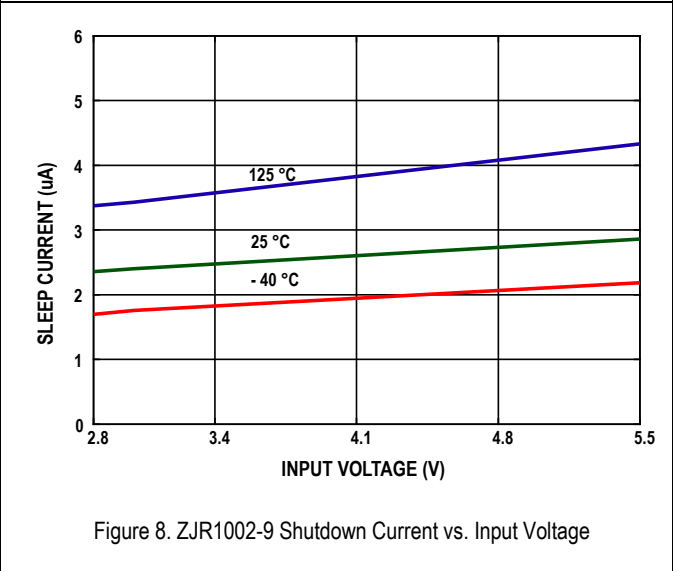
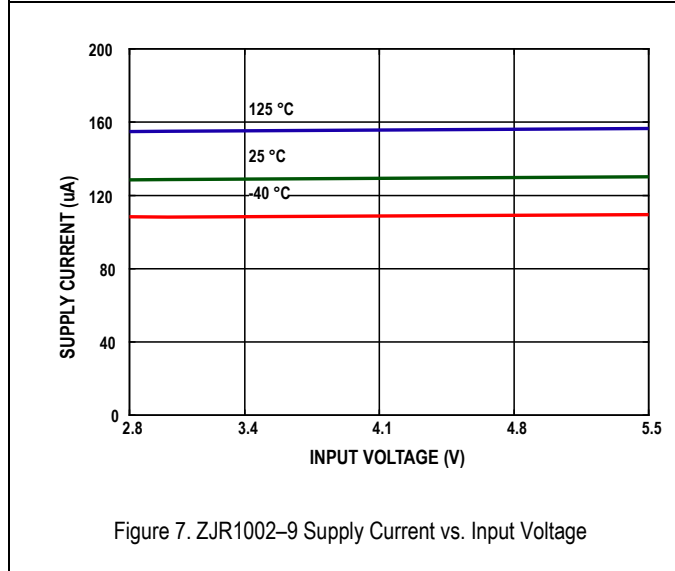
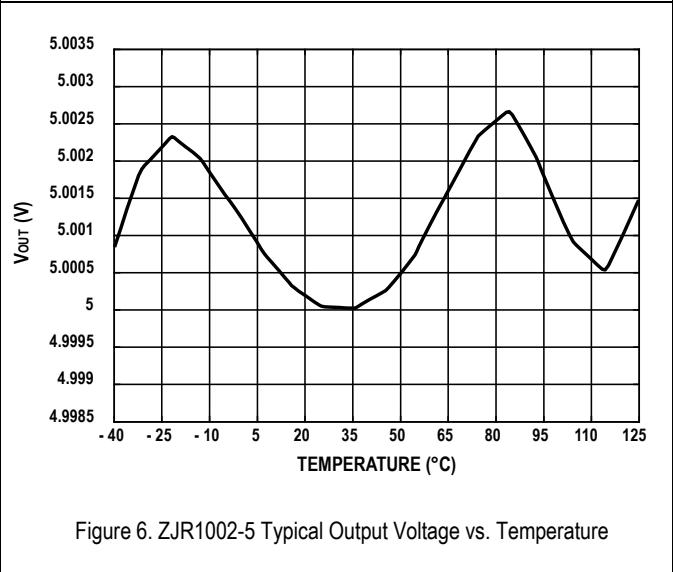
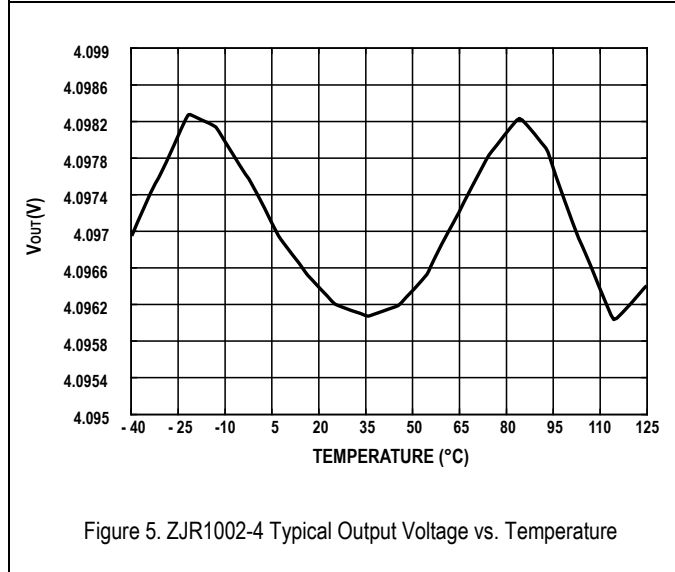
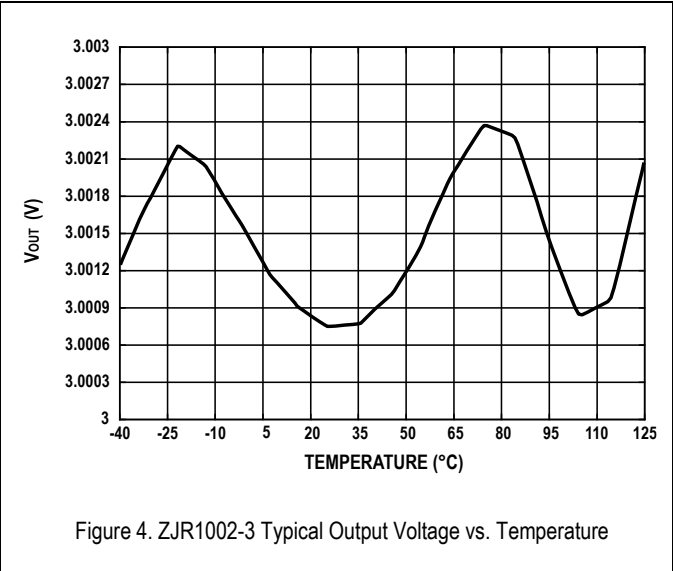
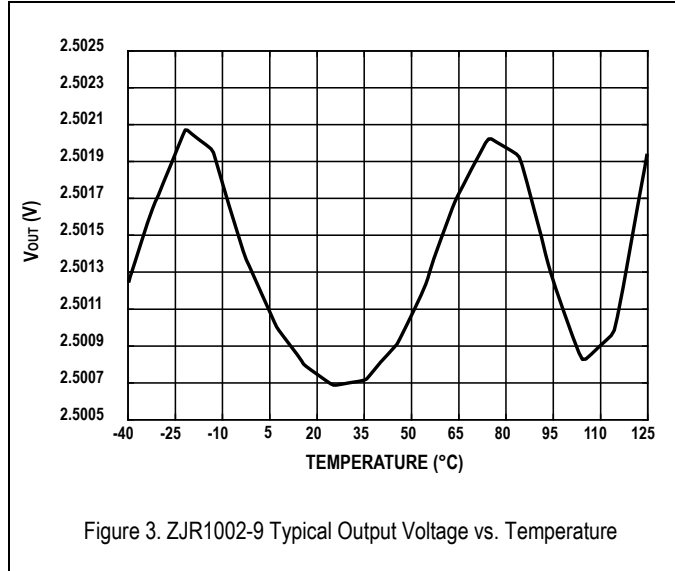

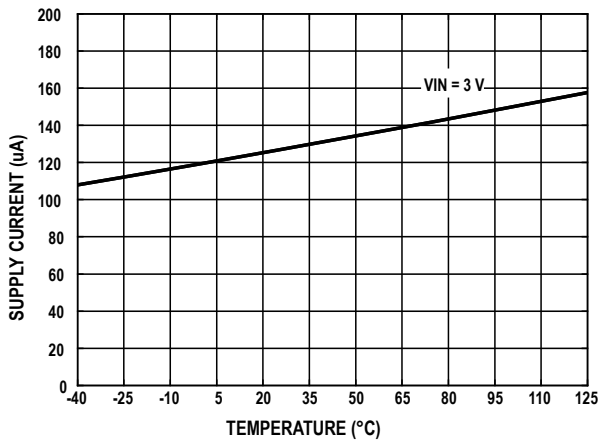

Figure 9. ZJR1002-9 Supply Current vs. Temperature

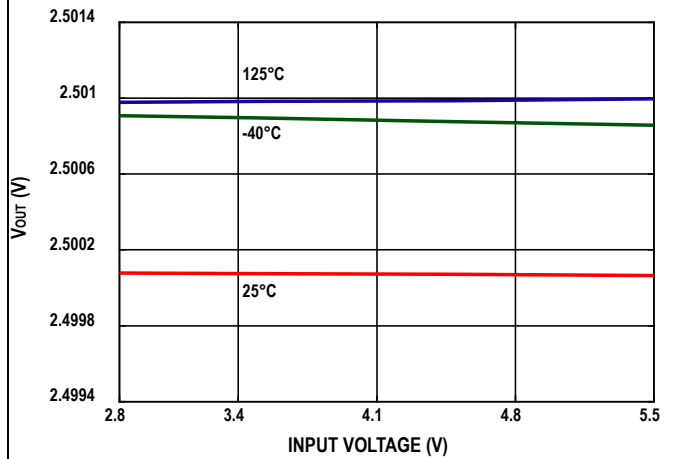

Figure 10. ZJR1002-9 Line Regulation

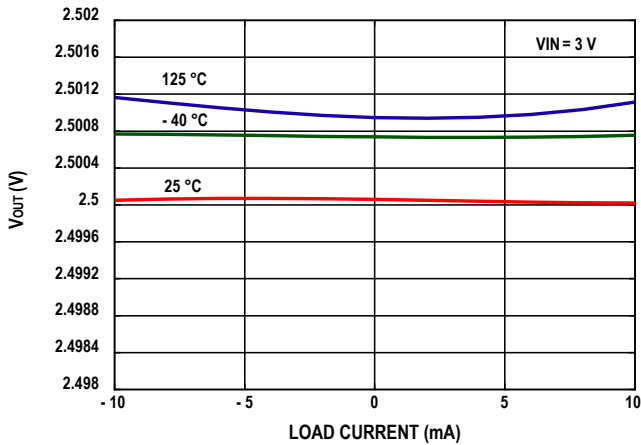

Figure 11. ZJR1002-9 Load Regulation

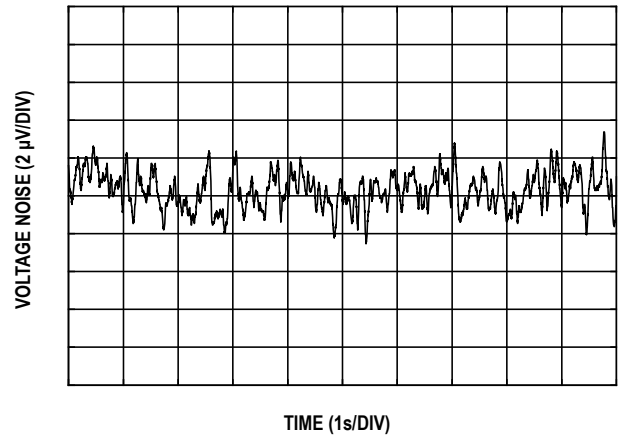

Figure 12. ZJR1002-9 Typical Voltage Noise (0.1 Hz to 10 Hz)

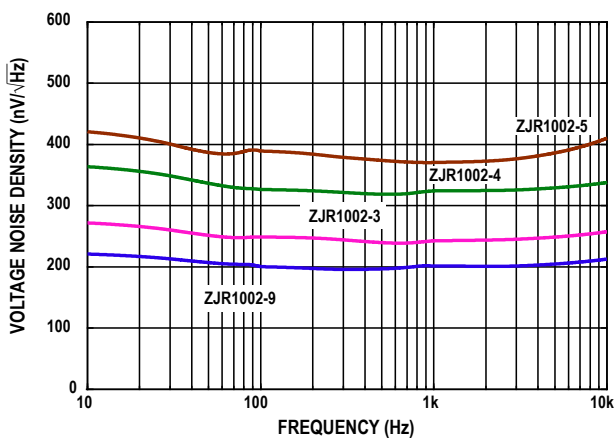

Figure 13. ZJR1002 Noise Density vs. Frequency

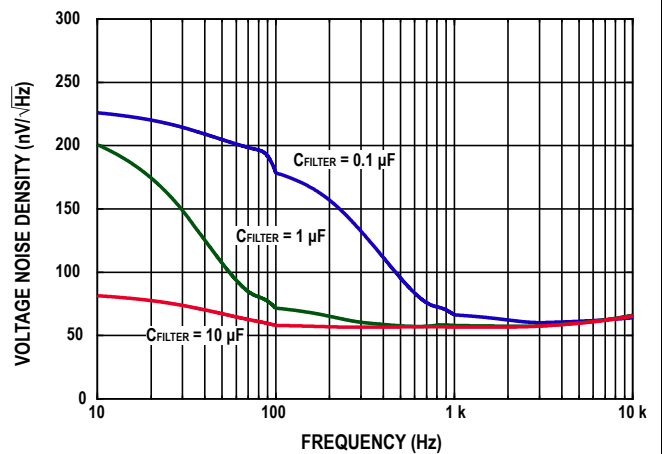

Figure 14. ZJR1001-9 Noise Density vs. Frequency

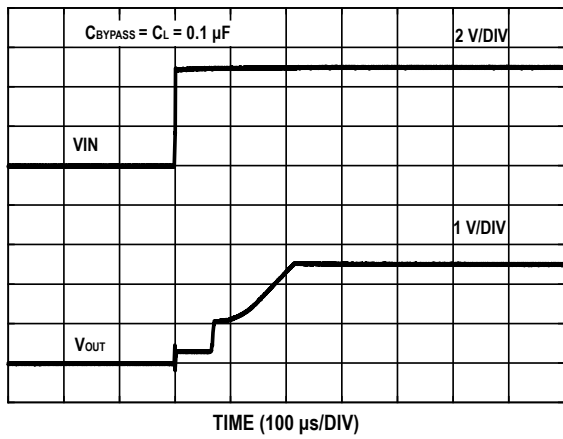

Figure 15. ZJR1002-9 Turn-On Response

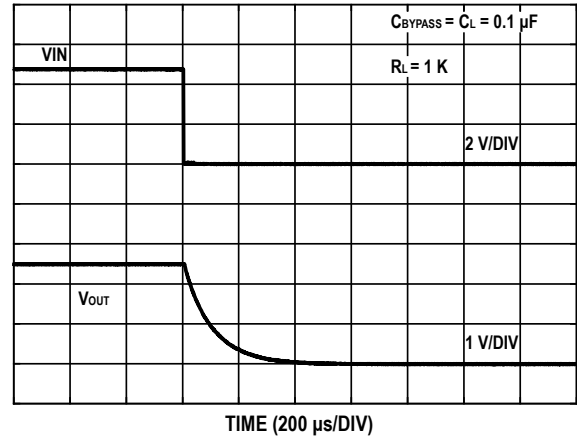

Figure 16. ZJR1002-9 Turn-Off Response

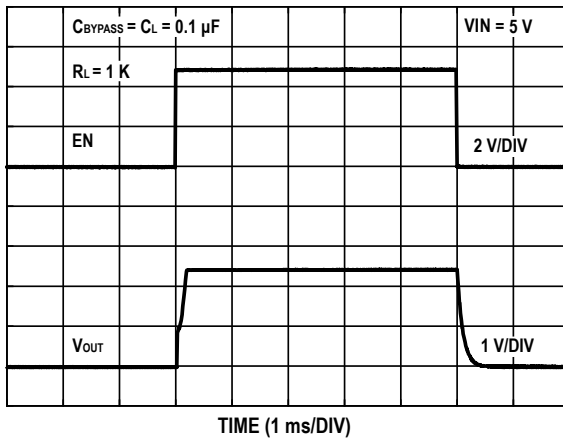

Figure 17. ZJR1002-9 Enable Transient

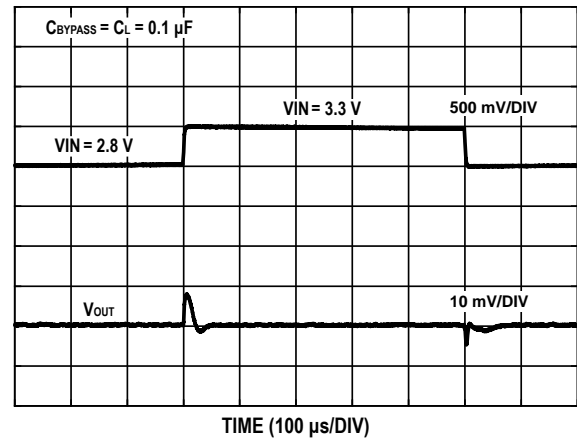

Figure 18. ZJR1002-9 Line Transient

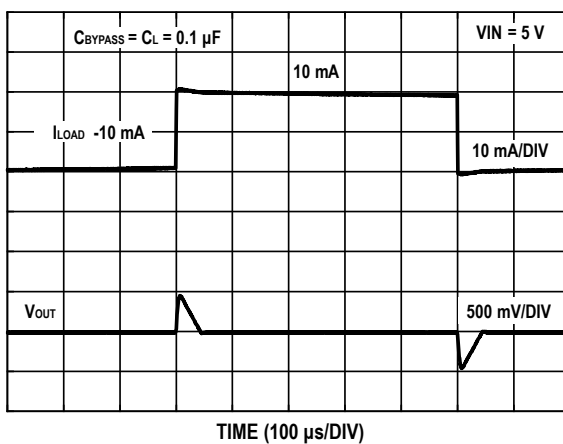

Figure 19. ZJR1002-9 Load Transient

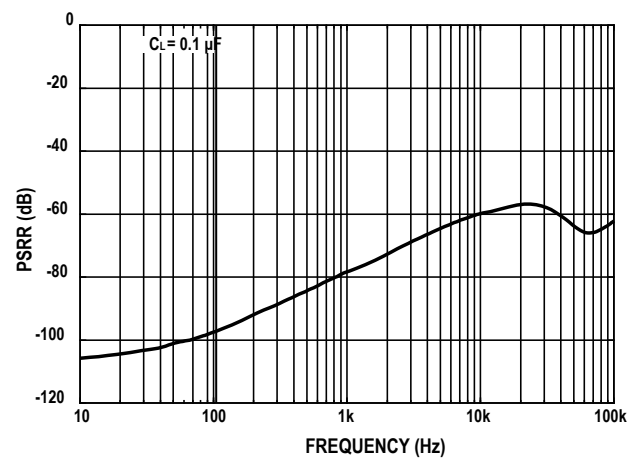

Figure 20. ZJR1002-9 Power Supply Rejection Ratio vs. Frequency

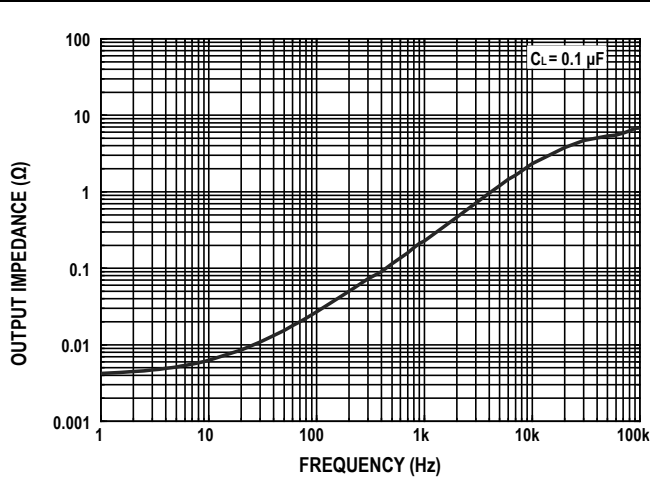

Figure 21. ZJR1002-9 Output Impedance vs. Frequency

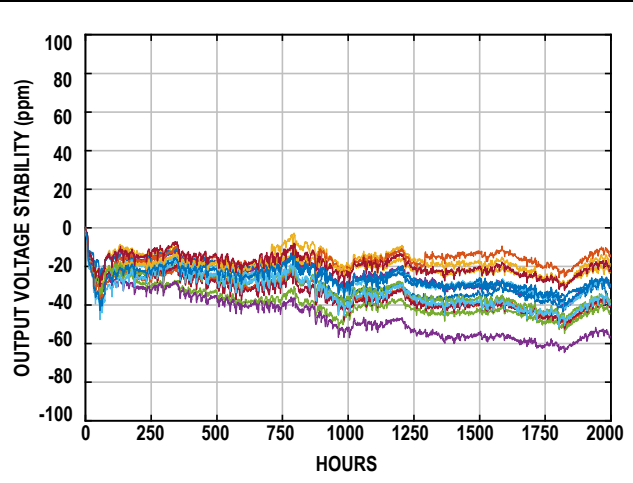

Figure 22. Long-Term Stability

Terminology

Temperature Coefficient

The change of output voltage over the operating temperature range is normalized by the output voltage at 25 °C, and expressed in ppm/°C as

$$dV_{OUT}/dT = \frac{V_{OUT(max)} - V_{OUT(min)}}{V_{OUT(25)} \times (T2 - T1)} \times 10^6$$

Where:

$V_{OUT(25)}$: Output voltage at 25 °C.

$V_{OUT(min)}$: The lowest output voltage over temperature T1 to T2 range.

$V_{OUT(max)}$: The highest output voltage over temperature range T1 to T2.

For ZJW Micro voltage references, temperature T1 is -40 °C, and T2 is +125 °C.

Long-term Stability

This is the measurement of the change in output voltage of the measured device at 25 °C after 1000 hours (approximately 42 days) of operation at a constant ambient temperature. Generally measured in ppm. Long-term stability is not only affected by variations in the device itself, but also by soldering and board materials. Long-term stability generally exhibits a logarithmic characteristic, therefore the change in the second 1000 hours will be much smaller than the change in the first 1000 hours.

$$LTD = \frac{V_{OUT(t0)} - V_{OUT(t1)}}{V_{OUT(t0)}} \times 10^6$$

where:

$V_{OUT(t0)}$: Output voltage at 25 °C at Time 0.

$V_{OUT(t1)}$: Output voltage at 25 °C at Time 1 after 1000 hours of operation under constant ambient temperature.

Thermal Hysteresis

The change of output voltage after the device is cycled through temperatures from +25 °C to -40 °C to +125 °C and back to +25°C. This is a typical value from a sample of parts put through such a cycle. It is normally in ppm using the following equation:

$$TH = \frac{V_{OUT(25)} - V_{OUT(TC)}}{V_{OUT(25)}} \times 10^6$$

where:

$V_{OUT(25)}$: Output voltage at 25 °C.

$V_{OUT(TC)}$: Output voltage at 25 °C after the temperature cycle.

Line Regulation

The change in output voltage due to a specified change in input voltage. It includes the effects of self-heating. Line regulation is expressed in either percent per volt, parts per million per volt, or microvolts per volt change in input voltage, such as ppm/V.

Load Regulation

The change in output voltage due to a specified change in load current. It includes the effects of self-heating. Load regulation is expressed in either microvolts per milliampere or parts per million per milliampere, such as ppm/mA.

Theory of Operation

ZJR1001, ZJR1002 series of precision voltage reference products is based on state-of-the-art CMOS technology, Figure 23 & Figure 24 shows ZJR1001 & ZJR1002's internal blocks respectively. The bandgap reference is the core, which has been carefully designed and can deliver the key performances by proprietary post-package trimming. All pins have the internal protection circuit in order to make ZJR1001 & ZJR1002 reliable parts, and their ESD level reaches 8 kV HBM.

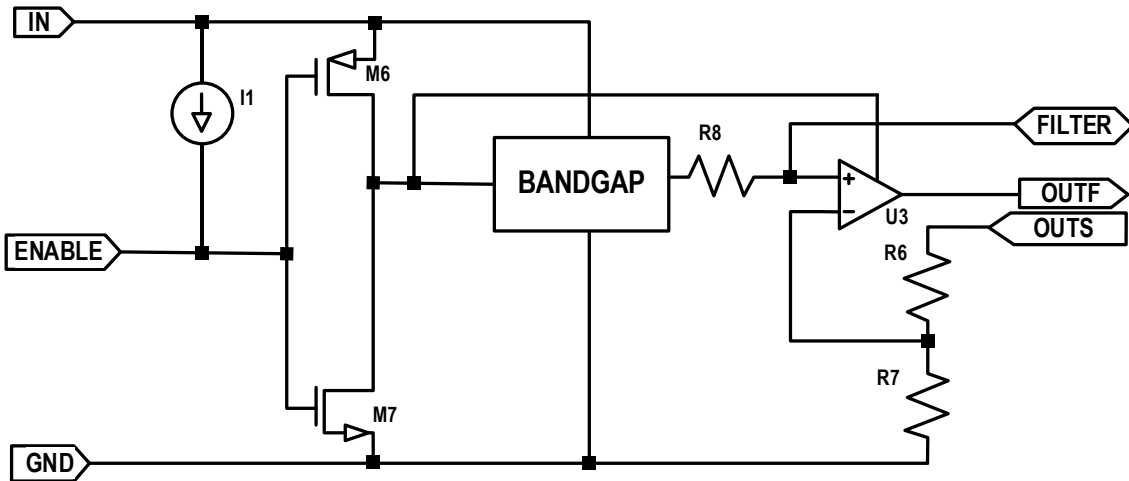

Figure 23. Simplified Schematic of ZJR1001

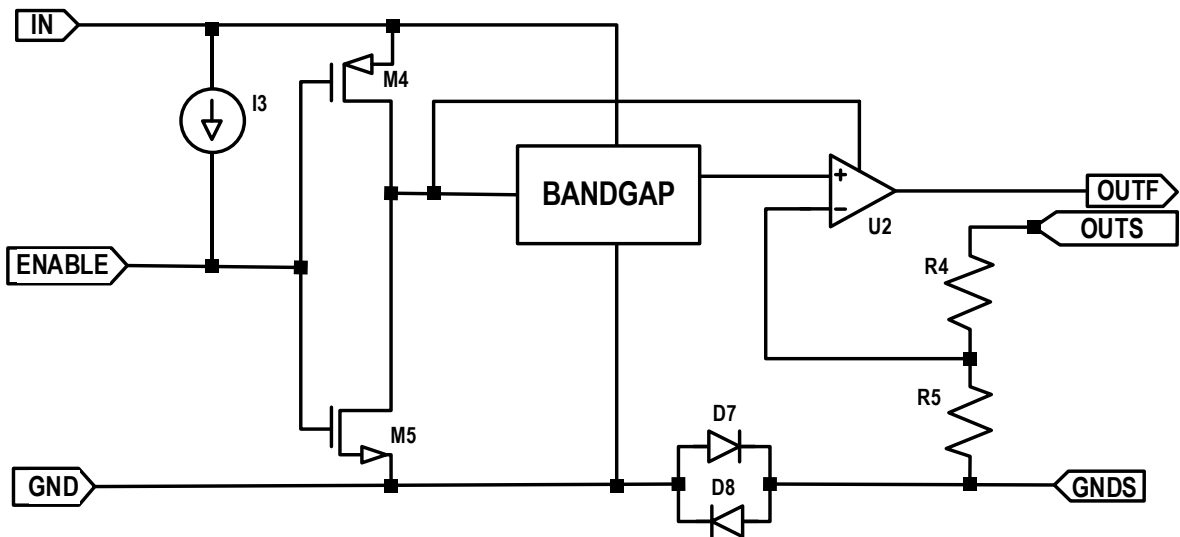

Figure 24. Simplified Schematic of ZJR1002

Applications

ZJR1001, ZJR1002 Basic Connections

Voltage references, including ZJR1001 & ZJR1002, normally require a capacitor at the output between OUTF and GND. Figure 25 is the basic connection of ZJR1001/2. Other than a 0.1 μF capacitor at the output, no further component is needed for normal operation. To reduce noise further, an additional capacitor can be connected to the FILTER pin of ZJR1001.

However, in actual system, the power supply may change rapidly. Adding a 1 μF to 10 μF capacitor at the input can help the performances of the voltage reference. An additional 0.1 μF capacitor in parallel can reduce power supply noise further.

The output capacitance ranges from 0.1 μF to 10 μF . Too big capacitive load can cause output oscillation. Capacitor equivalent series resistance (ESR) within 1.5 Ω is recommended to ensure its stability. Meanwhile, larger output capacitor results in longer turn-on time.

Capacitance value depends on the load of the voltage reference, source or sink current et al. New SAR ADC, such as ZJC2000, requires its voltage reference can source and sink current.

It is recommended to use surface-mounted ceramic capacitors (such as X5R, X7R). If an electrolytic capacitor is used at the output, a 0.1 μF ceramic capacitor should be placed in parallel to reduce the overall ESR at the output. In addition, the capacitors' operating temperature range should be wider, or at least the same as the system's temperature range.

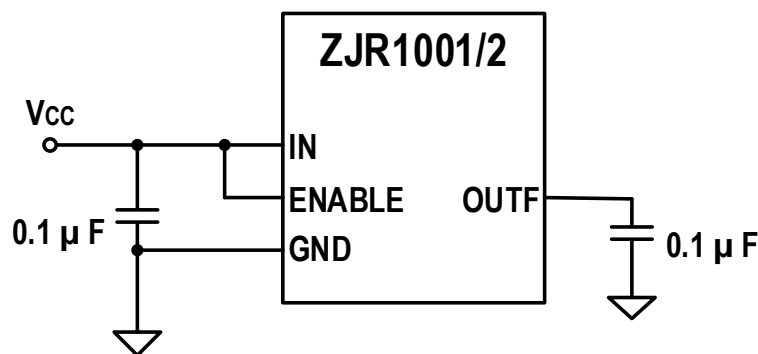

Figure 25. ZJR1001 /2 Basic Connections

Power on and Shutdown Mode

Figure 15 shows the turn-on process of ZJR1002 and ZJR1001 has the similar turn-on process. The value of the load capacitance affects the turn-on time. In general, the larger the load capacitance, the longer the settling time. Settling to higher accuracy sees exponentially longer turn-on time.

For power sensitive high precision applications, ZJR1001 and ZJR1002 have shutdown mode, which has the supply current of 3 μA across the specified temperature range. Drive pin 3 (ENABLE) low, the part will enter shutdown mode & high will be in normal operation as can be found in Figure 17. Leave pin 3 unconnected (there is a weak internal pull-up circuit) or connect to IN, ZJR1001 or ZJR1002 will be in normal operation.

Supply Voltage

The supply voltage of ZJR1001 and ZJR1002 ranges from 300 mV higher than the output voltage to 5.5 V. It is recommended to power ZJR1001 & ZJR1002 by linear power supplies, such as LDO, in order to get high performances.

Noise Performance

ZJR1001 and ZJR1002 have very low output noise. The noise of ZJR1002-9 is typically within 2.5 ppm_peak-to-peak over the 0.1 Hz to 10 Hz band. The noise measurement is made with a band-pass filter made of a high-pass filter with a corner frequency at 0.1 Hz and a low-pass filter with a corner frequency at 10 Hz.

Connect an external capacitor to pin 1 of ZJR1001 (FILTER) can further reduce its noise. By adding a 0.1 μ F capacitor, ZJR1001-9's noise at 1 kHz dropped from 200 nV/ $\sqrt{\text{Hz}}$ without capacitor to 60 nV/ $\sqrt{\text{Hz}}$. If the noise reduction is not needed, leave pin 1 unconnected.

Power Dissipation

ZJR1001 and ZJR1002 are low power dissipation devices with a typical supply current of 130 μ A. In case of heavy load, it is necessary to calculate the power dissipation of the device, and take into account the performance changes caused by it. The temperature of the device increases according to the equation below.

$$T_J = P_D \times \theta_{JA} + T_A$$

where:

T_J = Junction temperature ($^{\circ}\text{C}$)

T_A = Ambient temperature ($^{\circ}\text{C}$)

P_D = Power dissipated (W)

θ_{JA} = Junction-to-ambient thermal resistance ($^{\circ}\text{C}/\text{W}$)

The junction temperature of ZJR1001 and ZJR1002 must not exceed the absolute maximum rating of 150 $^{\circ}\text{C}$.

Product Applications

Voltage Reference Noise to ADC Resolution

In general, the voltage reference's 0.1 Hz to 10 Hz noise should be within ADC's 1/2 LSB. With the same resolution, the larger the full-scale voltage, the lower the noise requirement to the voltage reference as can be found in Table 1. ZJR1001 and ZJR1002 are able to be used as 16-bit ADC voltage reference.

Resolution (bit)	0.1 Hz to 10 Hz Noise ($\mu\text{V}_{\text{P-P}}$)	
	2.5 V full scale	5 V full scale
8	4,882.8	9,765.6
10	1,220.7	2,441.4
12	305.2	610.4
14	76.3	152.6
16	19.1	38.1
18	4.8	9.5

Table 1. ADC Resolution vs. Voltage Reference Noise

Using ZJR1002 and ZJC2542 to Build up to 18-bit Signal Sources

It is a great challenge to generate a programmable high-precision signal source with more than 16-bit accuracy. The high-performance voltage reference is required to ensure the noise and temperature performances of both voltage and current output signals. Also, for some systems, the performances over time (also known as time drift) are required. Based on ZJW Micro's complete high-performance signal chain products, the reference design is developed as shown in Figure 26. It can achieve up to 18-bit accuracy if ZJC2542-18 will be used together with ZJR1002. The Kelvin connection of ZJR1002 and the Kelvin connection requirement of 18-bit precision digital-to-analog converter (DAC) ZJC2542 matches well to improve the system's resistance to load changes and easy implementation. ZJR1002's low noise and temperature drift within 5ppm/ °C are critical to ensure the performance of the whole design.

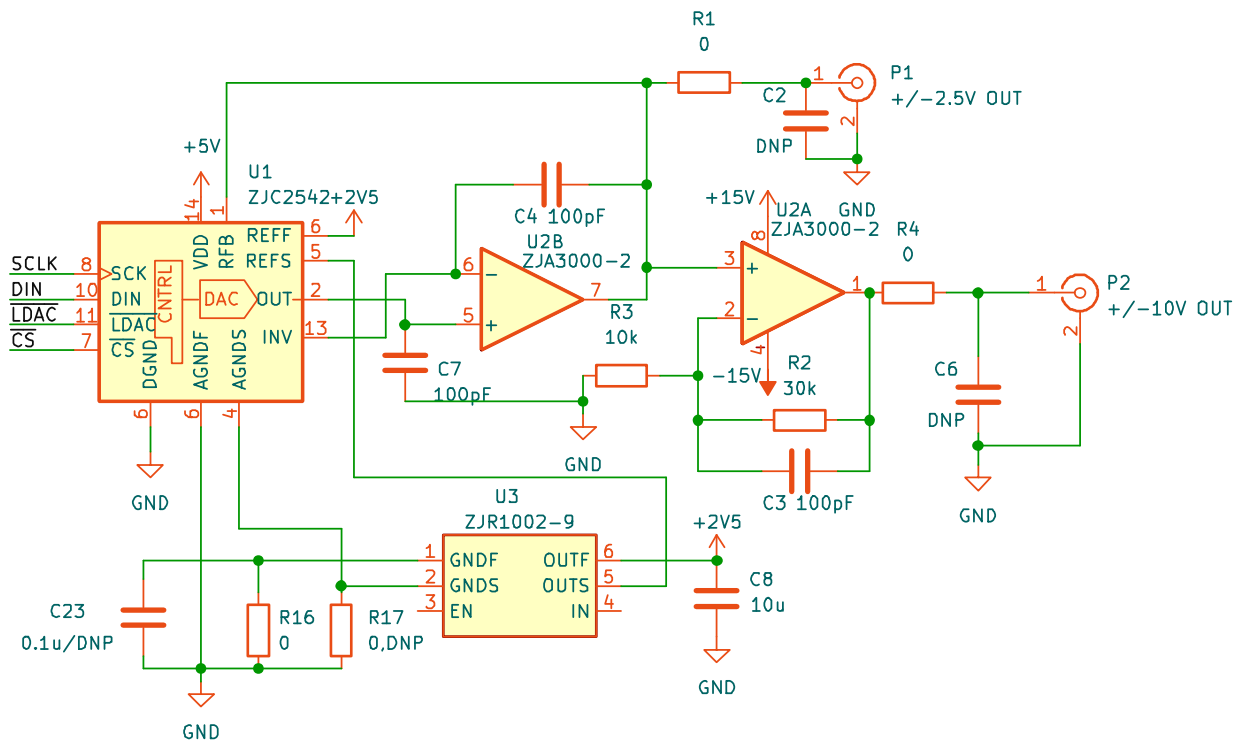

Figure 26. ZJR1002 and ZJC2542 build 18-bit programmable signal source

Layout Guidelines

- Place the power-supply bypass capacitor as closely as possible to the supply and ground pins. The recommended value of this bypass capacitor is from 1 μ F to 10 μ F. If necessary, additional decoupling capacitance can be added to compensate for noisy or high-impedance power supplies.
- The output must be decoupled with a bigger than 0.1 μ F capacitor. For better noise performance, the recommended ESR on the output capacitor is from 1 Ω to 1.5 Ω . For even lower noise, a larger capacitor in parallel or an RC filter can be added.
- Use large area ground plane if possible. Keep fast-changing or high-frequency interference signals far from ZJR1001 or ZJR1002.

Layout Example

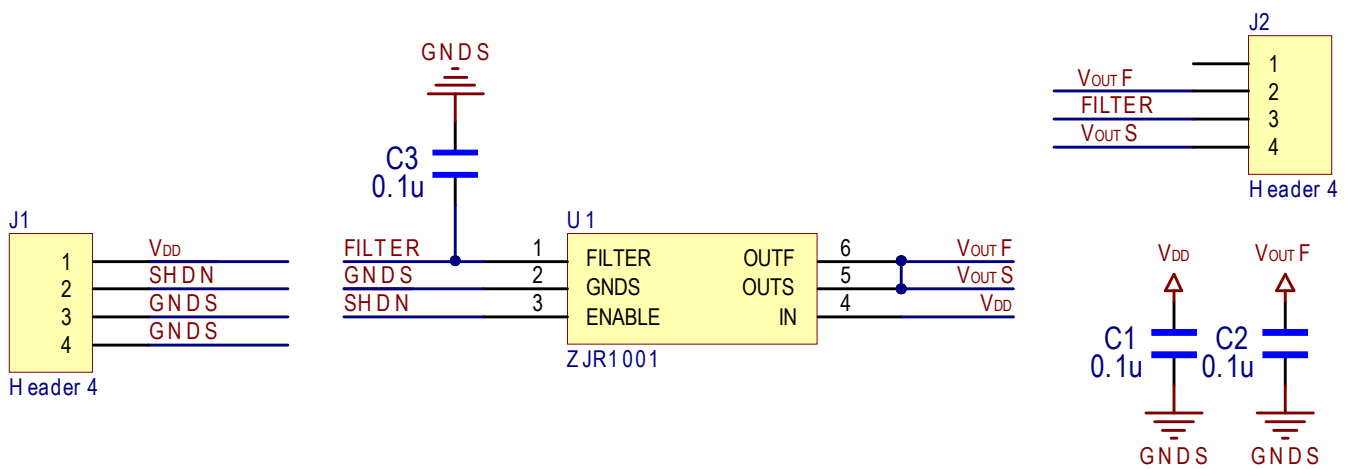

Figure 27. ZJR1001 Evaluation Board Schematic

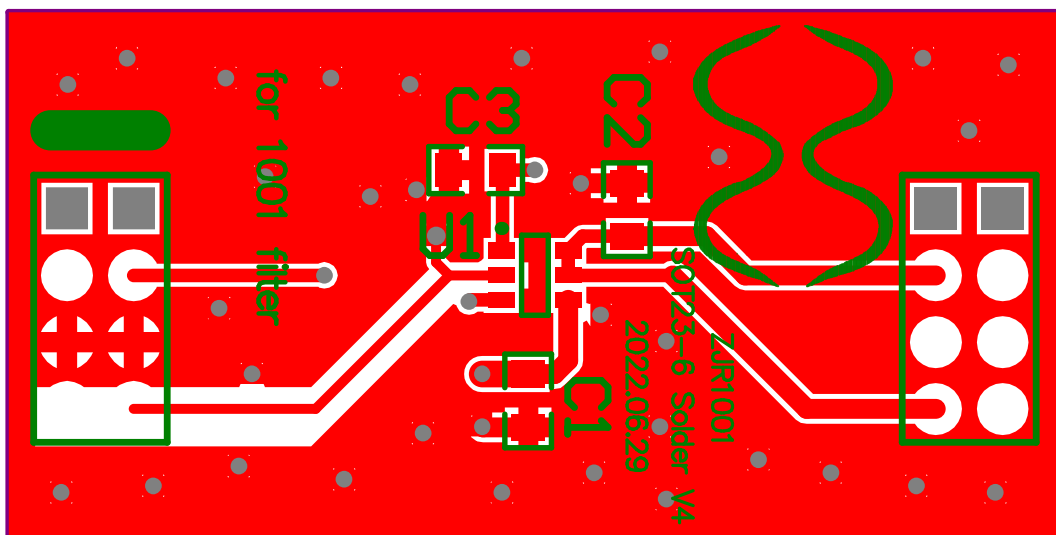

Figure 28. ZJR1001 Evaluation Board Layout (Top Layer)

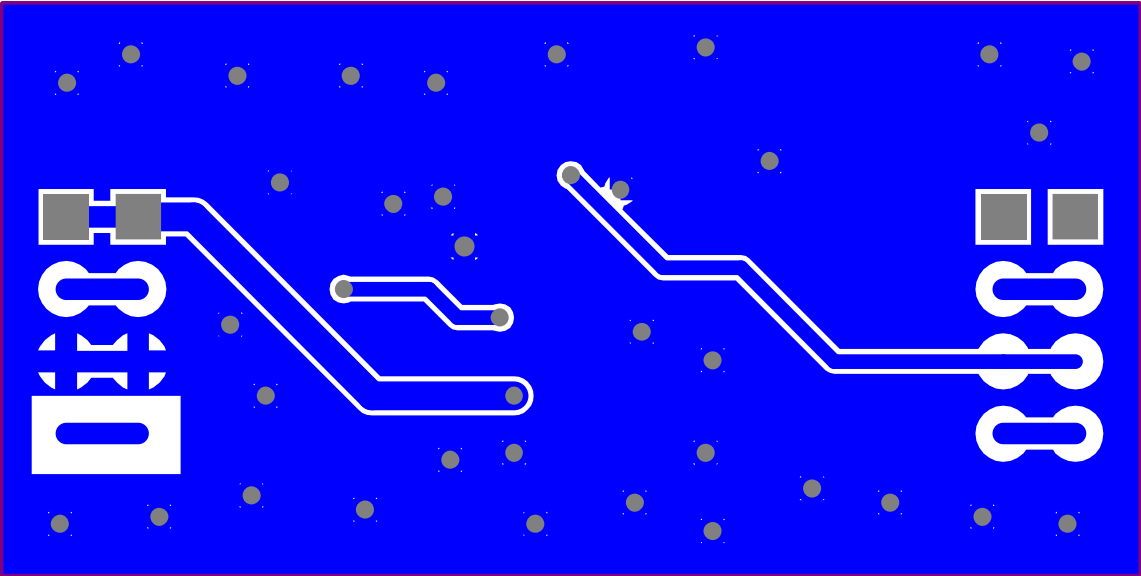

Figure 29. ZJR1001 Evaluation Board Layout (Bottom Layer)

Outline Dimensions

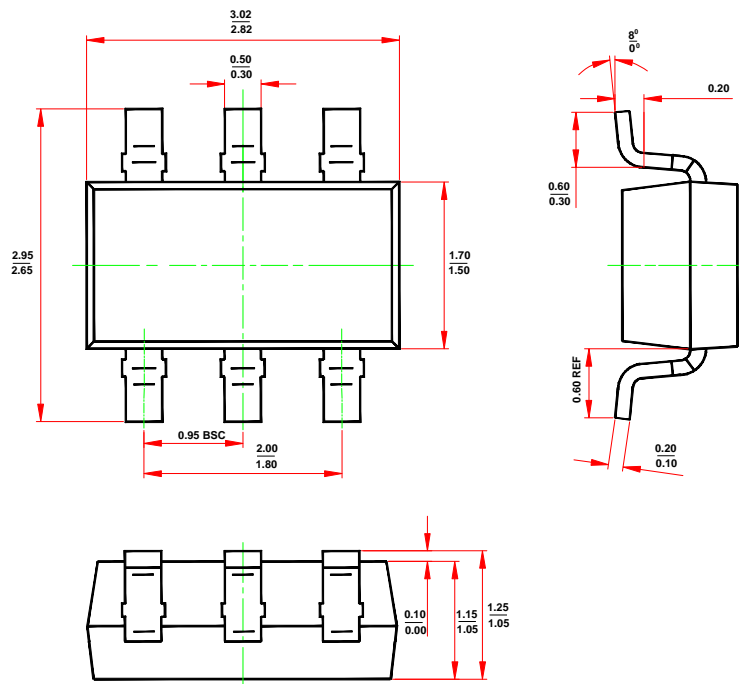
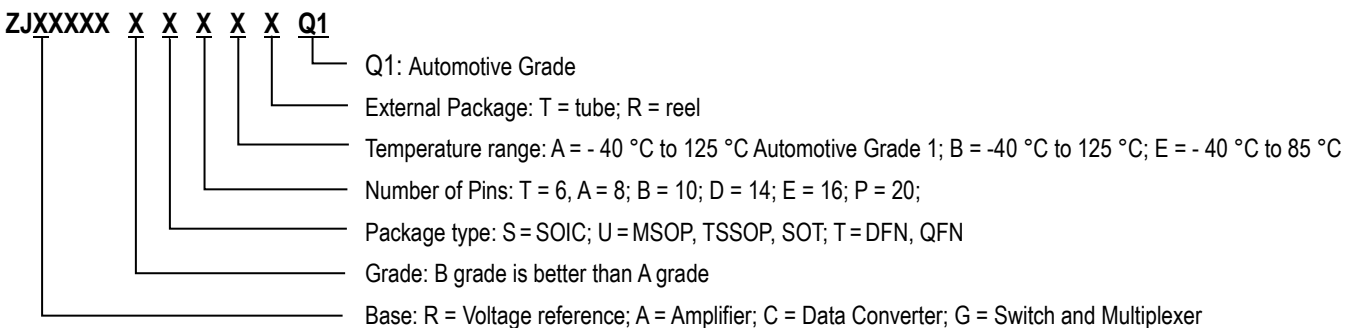

Figure 30. 6-Lead SOT23 Package Dimensions shown in millimeters

Ordering Guide

Model	Orderable Device	Package	Output Voltage (V)	Max TempCo (ppm/°C)	Mark	External Package
ZJR1001-9	ZJR1001-9BUTBR	SOT23-6	2.5	5	1001-9	7" reel
	ZJR1001-9AUTBR	SOT23-6		8	1001-9	7" reel
ZJR1001-3	ZJR1001-3BUTBR	SOT23-6	3	5	1001-3	7" reel
	ZJR1001-3AUTBR	SOT23-6		8	1001-3	7" reel
ZJR1001-4	ZJR1001-4 BUTBR	SOT23-6	4.096	5	1001-4	7" reel
	ZJR1001-4 AUTBR	SOT23-6		8	1001-4	7" reel
ZJR1001-5	ZJR1001-5 BUTBR	SOT23-6	5	5	1001-5	7" reel
	ZJR1001-5 AUTBR	SOT23-6		8	1001-5	7" reel
ZJR1002-9	ZJR1002-9BUTBR	SOT23-6	2.5	5	1002-9	7" reel
	ZJR1002-9AUTBR	SOT23-6		8	1002-9	7" reel
	ZJR1002-9AUTARQ1	SOT23-6		8	1002Q9	7" reel
ZJR1002-3	ZJR1002-3BUTBR	SOT23-6	3	5	1002-3	7" reel
	ZJR1002-3AUTBR	SOT23-6		8	1002-3	7" reel
	ZJR1002-3AUTARQ1	SOT23-6		8	1002Q3	7" reel
ZJR1002-4	ZJR1002-4BUTBR	SOT23-6	4.096	5	1002-4	7" reel
	ZJR1002-4AUTBR	SOT23-6		8	1002-4	7" reel
	ZJR1002-4AUTARQ1	SOT23-6		8	1002Q4	7" reel
ZJR1002-5	ZJR1002-5BUTBR	SOT23-6	5	5	1002-5	7" reel
	ZJR1002-5AUTBR	SOT23-6		8	1002-5	7" reel
	ZJR1002-5AUTARQ1	SOT23-6		8	1002Q5	7" reel

Orderable Device Explanation



Related Device

Part Number	Description	Comments
ADC		
ZJC2000/2010	18-bit 400 kSPS/200 kSPS SAR ADC	Fully differential input, SINAD 99.3 dB, THD - 113 dB
ZJC2001/2011	16-bit 500 kSPS/250 kSPS SAR ADC	Fully differential input, SINAD 95.3 dB, THD - 113 dB
ZJC2002/2012	16-bit 500 kSPS/250 kSPS SAR ADC	Pseudo-differential unipolar input, SINAD 91.7 dB, THD - 105 dB
ZJC2003/2013		Pseudo-differential bipolar input, SINAD 91.7 dB, THD - 105 dB
ZJC2004/2014	18-bit 400 kSPS/200 kSPS SAR ADC	Pseudo-differential unipolar input, SINAD 94.2 dB, THD - 105 dB
ZJC2005/2015		Pseudo-differential bipolar input, SINAD 94.2 dB, THD - 105 dB
ZJC2007/2017	14-bit 600 kSPS/300 kSPS SAR ADC	Pseudo-differential unipolar input, SINAD 85 dB, THD - 105 dB
ZJC2008/2018		Pseudo-differential bipolar input, SINAD 85 dB, THD - 105 dB
ZJC2100/1-18	18-bit 400 kSPS/200 kSPS 4-ch differential SAR ADC, SINAD 99.3 dB, THD - 113 dB	
ZJC2100/1-16	16-bit 500 kSPS/250 kSPS 4-ch differential SAR ADC, SINAD 95.3 dB, THD - 113 dB	
ZJC2102/3-18	18-bit 400 kSPS/200 kSPS 8-ch pseudo-differential SAR ADC, SINAD 94.2 dB, THD - 105 dB	
ZJC2102/3-16	16-bit 500 kSPS/250 kSPS 8-ch pseudo-differential SAR ADC, SINAD 91.7 dB, THD - 105 dB	
ZJC2102/3-14	14-bit 600 kSPS/300 kSPS 8-ch pseudo-differential SAR ADC, SINAD 85 dB, THD - 105 dB	
ZJC2104/5-18	18-bit 400 kSPS/200 kSPS 4-ch pseudo-differential SAR ADC, SINAD 94.2 dB, THD - 105 dB	
ZJC2104/5-16	16-bit 500 kSPS/250 kSPS 4-ch pseudo-differential SAR ADC, SINAD 91.7 dB, THD - 105 dB	
DAC		
ZJC2541-18/16/14	18/16/14-bit 1 MSPS single channel DAC with unipolar output	Power on reset to 0 V (ZJC2541) or $V_{REF}/2$ (ZJC2543), 1 nV-S glitch, SOIC-8/MSOP-10/DFN-10 packages
ZJC2543-18/16/14		
ZJC2542-18/16/14	18/16/14-bit 1 MSPS single channel DAC with bipolar output	Power on reset to 0 V (ZJC2542) or $V_{REF}/2$ (ZJC2544), 1 nV-S glitch, SOIC-14/TSSOP-16/QFN-16 packages
ZJC2544-18/16/14		
Amplifier		
ZJA3000-1/2/4	Single/Dual/Quad 36 V low bias current precision Op Amps	3 MHz GBW, 35 μ V max Vos, 0.5 μ V/ $^{\circ}$ C max Vos drift, 25 pA max Ibias, 1 mA/Amplifier, input to V-, RRO, 4.5 V to 36 V
ZJA3001-1/2/4	Single/Dual/Quad 36 V low bias current precision Op Amps	3 MHz GBW, 35 μ V max Vos, 0.5 μ V/ $^{\circ}$ C max Vos drift, 25 pA max Ibias, 1 mA/Amplifier, RRO, 4.5 V to 36 V
ZJA3512-2/4	Dual/Quad 36 V 7 MHz precision JFET Op Amps	7 MHz GBW, 35 V/ μ S SR, 50 μ V max Vos, 1 μ V/ $^{\circ}$ C max Vos drift, 2 mA/Amplifier, RRO, 4.5V to 35 V
ZJA3600/1	36 V ultra-high precision in-amp	CMRR 105 dB min (G = 1), 25 pA max Ibias, 25 μ V max Vosi, gain error 0.001 % max (G = 1), 625 kHz BW (G = 10), 3.3 mA/Amplifier, \pm 2.4 V to \pm 18 V, - 40 $^{\circ}$ C to 125 $^{\circ}$ C specified
ZJA3622/8	36 V low cost precision in-amp	CMRR 93 dB min (G = 10), 0.5 nA max Ibias, 125 μ V max Vosi, 625 kHz BW (G = 10), 3.3 mA/Amplifier, \pm 2.4 V to \pm 18 V
ZJA3611, ZJA3609	36 V ultra-high precision wider bandwidth precision in-amp (min gain of 10)	CMRR 120 dB min (G = 10), 25 pA max Ibias, 25 μ V max Vosi, 1.2 MHz BW (G = 10), 3.3 mA/Amplifier, \pm 2.4 V to \pm 18 V, - 40 $^{\circ}$ C to 125 $^{\circ}$ C specified
ZJA3676/7	Low power, G = 1 Single/Dual 36 V difference amplifier	Input protection to \pm 65 V, CMRR 104 dB min, Vos 100 μ V max, gain error 15 ppm max, 500 kHz BW, 330 μ A, 2.7 to 36 V
Voltage Reference		
ZJR1000	15 V supply precision voltage reference	$V_{OUT} = 1.25/2.048/2.5/3/4.096/5$ V, 5 ppm/ $^{\circ}$ C max drift - 40 $^{\circ}$ C to 125 $^{\circ}$ C, \pm 0.05 % initial error
ZJR1001	5.5V low power voltage reference (ZJR1001 with noise filter option)	$V_{OUT} = 2.5/3/4.096/5$ V, 5 ppm/ $^{\circ}$ C max drift - 40 $^{\circ}$ C to 125 $^{\circ}$ C, \pm 0.05 % initial error, 130 μ A, ZJR1001/2 in SOT23-6, ZJR1003 in SOIC/MS-8
ZJR1002		
ZJR1003		
Switches and Multiplexers		
ZJG4438/4439	36V fault protection 8:1/dual 4:1 multiplexer	Protection to \pm 50 V power on & off, latch-up immune, Ron 270 Ω , 14.8 pC charge injection, t_{ON} 166 nS, 10 V to 36 V