

SCHMATIC

MODEL CODE

SS-12D16	X	X	X
Knob Type	H(mm)		Colour
L	2~12		Blank: Standard Black
G			R: Red

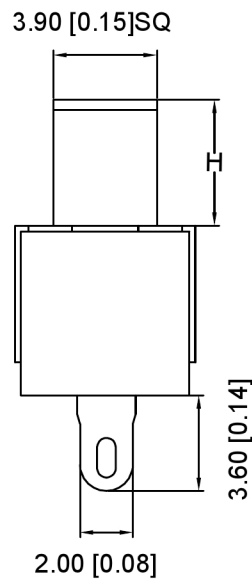
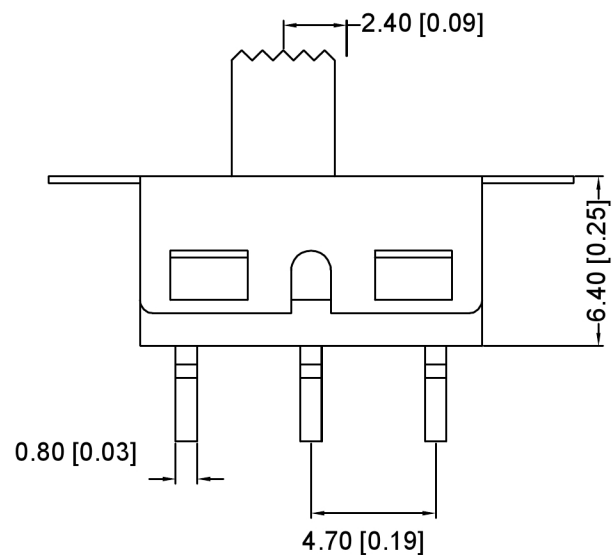
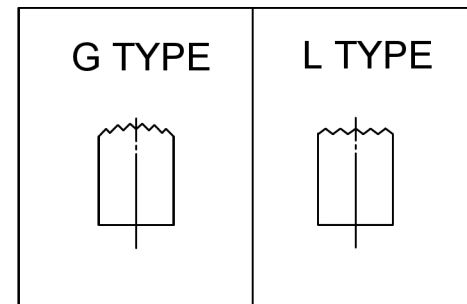

Typical Specifications

1. Rating: AC 125V 3A
2. Insulation Resistance: 1,000M min
3. Dielectric strength: 1,500V RMS
4. Operating Life: 10,000 cycles

ITEM	PAPT NAME	TER,NO	QTY	MATERIAL	FINISHING	REMARK
⑤	Terminal	—	3	Copper Alloy	silver plated	———
④	Contact	—	1	Copper Alloy	silver plated	———
③	Housing	—	1	Stainless Steel		———
②	Slide Handle	—	1	Nylon		———
①	Case	—	1	Diallyl Phthalate (DAP)		———

广东星坤科技股份有限公司

ΔX		日期
ΔX		日期
ΔX		日期
MARK		

文件工程章

REVISIONS	DATE	REVISED	APPROVED	DESCRIPTION

ANGLAR	±5°	XKIB
L ≤ 4	±0.2	
4 < L ≤ 16	±0.3	
16 < L ≤ 63	±0.4	
L > 63	±0.5	
UNSPECIFIED TOLERANCES		XKB INDUSTRIAL PRECISION CO., LIMITED

DSND		SCALE: N/A	MODEL TYPE: SLIDE SWITCH
DWN		VIEW:	PART NO.: SS-12D16XXX
CHKD		UNIT: mm/in	DWG NO.:
APPD		SIZE: A4	
WEIGHT	SHEET	REVISIC	
	1/1	A0	