

EXTREME LOW POWER RTC WITH I²C, 32-bit UNIX time counter, 43 bytes EEPROM, Battery Switchover and Trickle Charger



FEATURES

- | Extreme low power consumption: **45 nA @ 3 V**.
- | Wide operating voltage range: 1.2 V to 5.5 V.
- | Built-in tuning Fork crystal at 32'768 Hz
- | Time accuracy: possible to calibrate to **±1 ppm @ 25°C**
- | Non-volatile configuration settings with user programmable offset value.
- | Configuration stored in EEPROM and mirrored in RAM
- | Password protection to secure configuration registers
- | Backup Switch and Trickle Charger function.
- | Provides year, month, date, weekday, hours, minutes and seconds.
- | Automatic leap year correction; 2000 to 2099
- | 32 bit UNIX time counter.
- | Timer, alarm and external event functions with time stamp
- | Clock output: 32.768 kHz, 8192 Hz, 1024 Hz, 64 Hz, 32Hz, 1 Hz.
- | 43 bytes non-volatile user memory, 2 bytes user RAM.
- | I²C-bus interface: 400 kHz.
- | Package: TSSOP14, 100% Pb-free, RoHS-compliant
- | Also available in ultra-small SMD C7 package, factory calibrated and including the 32kHz crystal, part number EM3028-C7

DESCRIPTION

The EM3028 engineered using the in-house analog low power (ALP) technology provides unmatched true ultra-low current consumption of typically 40nA while running on a standard 32'768 Hz tuning fork crystal. Thus allowing several hours of backup supply using cost effective MLCC capacitors.

It provides full RTC function with programmable counters, alarm, selectable interrupt and clock output functions and also a 32-bit UNIX Time counter.

The internal EEPROM memory hosts all configuration settings and allows for additional 43 bytes of user memory.

All addresses and data are transferred over an I²C-bus interface for communication with a host controller.

It is available in a TSSOP14 plastic package or as a module combining the 32 kHz Crystal with the RTC IC in an ultra-small, hermetically sealed C7 SMD package, factory calibrated to an initial accuracy of +/- 1ppm.

APPLICATIONS

- | IoT
- | Wearable systems
- | Multi-Solar cell platforms
- | Beacons and wireless sensor networks
- | Industrial and environmental monitoring
- | Battery operated platform

TYPICAL APPLICATION

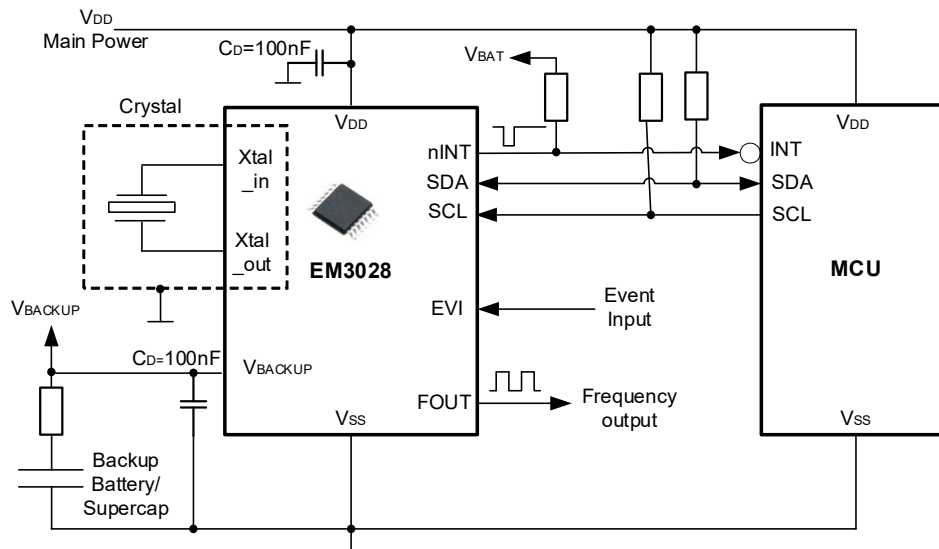


TABLE OF CONTENTS

1. Product description	9
1.1. Block diagram	9
1.2. Operating modes	10
1.2.1. Device Protection	10
1.2.2. Register Organization	10
1.2.3. Register Overview	11
2. Handling Procedures	13
3. Pin description	13
4. Package / Pin Out / Marking	14
5. Electrical specifications	15
5.1. Absolute Maximum Ratings	15
5.2. Operating Conditions	15
5.3. Electrical Characteristics	16
5.4. Oscillator Characteristics	19
5.5. Timing Characteristics	20
5.5.1. POWER ON	20
5.5.2. I ² C-BUS Characteristics	21
6. Product configuration	22
6.1. Clock Registers	22
6.2. Calendar Registers	23
6.3. Alarm Registers	25
6.4. Periodic Countdown Timer Control Registers	27
6.5. Configuration Registers	29
6.6. Event Control Register	33
6.7. Time Stamp Registers	34
6.8. UNIX Time Registers	37
6.9. RAM Registers	38
6.10. PASSWORD Registers	39
6.11. EEPROM Memory Control Registers	40
6.12. ID Register	41
6.13. Configuration EEPROM with RAM Mirror Registers	41
6.13.1. EEPROM Reserved	41
6.13.2. EEPROM Password Enable Register	41
6.14. EEPROM Password Registers	42
6.15. EEPROM FOUT Register	43
6.16. EEPROM OFFSET Register	44
6.17. EEPROM BACKUP Register	45
6.18. USER EEPROM	46
6.19. MANUFACTURER EEPROM	46
6.20. Register Reset Values Summary	47
7. Detailed Functional Description	50
7.1. POWER ON RESET (POR)	50

7.2. AUTOMATIC BACKUP Switchover Function.....	50
7.2.1. SWITCHOVER Disabled	51
7.2.2. Direct Switching Mode (DSM).....	51
7.2.3. STANDBY MODE	52
7.2.4. Level Switching Mode (LSM)	52
7.3. Trickle Charger	53
7.4. Programmable Clock Output	53
7.4.1. FOUT Frequency Selection	54
7.4.2. Normal Clock Output	54
7.4.3. Interrupt Controlled Clock Output	54
7.4.4. Synchronized Enable/Disable	55
7.4.5. Clock Output Scheme.....	56
7.5. Setting and Reading the Time	57
7.5.1. Setting the Time	58
7.5.2. Reading the Time	58
7.6. EEPROM READ/WRITE.....	59
7.6.1. POR Refresh (ALL CONFIGURATION EEPROM → RAM)	59
7.6.2. AUTOMATIC Refresh (ALL CONFIGURATION EEPROM → RAM).....	59
7.6.3. Refresh (ALL CONFIGURATION EEPROM → RAM).....	59
7.6.4. Update (ALL CONFIGURATION RAM → EEPROM).....	59
7.6.5. READ ONE EEPROM BYTE (EEPROM → RAM-EEdata)	59
7.6.6. Write to ONE EEPROM BYTE (RAM-EEdata → EEPROM).....	59
7.6.7. EEBUSY Bit.....	60
7.6.8. EEPROM Read/Write Conditions	61
7.7. Use of the Configuration EEPROM WITH RAM MIRROR Registers	61
7.8. Interrupt Output.....	62
7.8.1. Servicing Interrupts.....	62
7.8.2. Interrupt Scheme	63
7.9. Periodic Countdown Timer Interrupt Function	65
7.9.1. Periodic Countdown Timer Diagram.....	66
7.9.2. Use of the Periodic Countdown Timer Interrupt.....	67
7.9.3. First Period Duration.....	69
7.10. Periodic Time Update Interrupt Function	70
7.10.1. Periodic Time Update Diagram.....	70
7.10.2. Use of the Periodic Time Update Interrupt.....	71
7.11. Alarm Interrupt Function	72
7.11.1. Alarm Diagram.....	72
7.11.2. Use of The Alarm Interrupt	73
7.12. External Event Function.....	74
7.12.1. External Event Diagram.....	75
7.12.2. Use of the External Event Function	76
7.13. Automatic BACKUP Switchover Interrupt Function.....	78
7.13.1. Automatic Backup Switchover Diagram.....	79

7.13.2. Use of the Automatic BACKUP Switchover Interrupt.....	80
7.14. POWER ON RESET Interrupt Function.....	81
7.14.1. POWER ON RESET Diagram.....	81
7.14.2. Use of the POWER ON RESET Interrupt.....	82
7.15. TIME STAMP Function.....	83
7.16. Frequency OFFSET Correction.....	85
7.16.1. EEOFFSET Value Determination.....	85
7.16.2. Verification of the Corrected Time Accuracy.....	85
7.17. UNIX Time Counter.....	86
7.18. RESET bit Function.....	87
7.19. User Programmable Password.....	88
7.19.1. Enabling/Disabling Write Protection.....	88
7.19.2. Changing Password.....	89
7.19.3. Flowchart.....	90
7.20. I ² C Interface.....	91
7.20.1. Bit Transfer.....	91
7.20.2. START and STOP Conditions.....	91
7.20.3. DATA Valid.....	92
7.20.4. System Configuration.....	92
7.20.5. Acknowledge.....	93
7.20.6. Slave Address.....	94
7.20.7. WRITE Operation.....	94
7.20.8. READ Operation at Specific Address.....	95
7.20.9. READ Operation.....	95
7.20.10. I ² C-BUS in Switchover Condition.....	96
8. Typical Application.....	97
8.1. Operating EM3028 with Backup Supply Voltage.....	97
8.2. Crystal Layout Guideline.....	98
9. Ordering Information.....	99
10. Packaging Information.....	100
10.1. 14LD TSSOP (rev C).....	100
10.2. Tape & Reel Information.....	101

LIST OF FIGURES

Figure 1-1 EM3028 Block Diagram.....	9
Figure 1-2 Address register auto-increment.....	10
Figure 1-3 Device Diode Protection Diagram.....	10
Figure 4-1 14LD TSSOP.....	14
Figure 4-2 Laser marking 14LD TSSOP	14
Figure 5-1 Battery Consumption, $T_{OPR} = 25^{\circ}C$, $V_{DD} = 2.1V$, $V_{DD} > V_{th_swbat}$, Level Switching	17
Figure 5-2 XTAL Frequency vs Temperature Characteristics	19
Figure 5-3 Power On Timing Diagram	20
Figure 5-4 I ² C BUS Timing Diagram	21
Table 6 5 I ² C Timing Characteristics.....	21
Figure 7-1 Direct Switching Mode.....	51
Figure 7-2 Level Switching Mode.....	52
Figure 7-3 Trickle Charger configuration	53
Figure 7-4 Frequency Output configuration	55
Figure 7-5 Frequency Output scheme	56
Figure 7-6 Setting and Reading the Time	57
Figure 7-7 Access time for Read/Write Operations.....	57
Figure 7-8 EEbusy bit	60
Figure 7-9 Interrupt Scheme (Part 1).....	63
Figure 7-10 Interrupt Scheme (Part 2).....	64
Figure 7-11 Periodic Countdown Timer Interrupt.....	66
Figure 7-12 Periodic Countdown Timer Interrupt	68
Figure 7-13 Periodic Countdown Timer Interrupt, countdown starting synchronization	68
Figure 7-14 Periodic Time Update Interrupt.....	70
Figure 7-15 Alarm Interrupt.....	72
Figure 7-16 External Event	75
Figure 7-17 External Event function, No filtering example, $EIE = 1$	77
Figure 7-18 External Event function, with Filtering example, $EIE = 1$	77
Figure 7-19 Automatic Backup Switchover	79
Figure 7-20 Power On Reset Interrupt.....	81
Figure 7-21 Time Stamp Scheme	84
Figure 7-22 Unix Time Counter.....	86
Figure 7-23 Reset bit Function.....	87
Figure 7-24 User Programmable Password Flowchart	90
Figure 7-25 I ² C Bit Transfer	91
Figure 7-26 I ² C Start and Stop Conditions.....	91
Figure 7-27 I ² C System Configuration	92
Figure 7-28 I ² C Acknowledge	93
Figure 7-29 I ² C Write Operation	94
Figure 7-30 I ² C Master reads data from slave EM3028 at specific address	95
Figure 7-31 I ² C Master reads data from slave EM3028 immediately after first byte	95
Figure 8-1 Example of Application.....	97

Figure 10-1 14LD TSSOP Package Outline Drawing	100
Figure 10-2 Tape & Reel diagram & orientation on tape.....	101

LIST OF TABLES

Table 1 Pin Out description.....	13
Table 2 Absolute maximum ratings.....	15
Table 3 Operating Conditions	15
Table 4 Electrical Specifications	16
Table 5 Timing Characteristics	20
Table 6 5 I ² C Timing Characteristics.....	21
Table 7 Seconds (0x00h).....	22
Table 8 Minutes (0x01h).....	22
Table 9 Hours (0x02h).....	22
Table 10 Weekday (0x03h).....	23
Table 11 Date (0x04h).....	23
Table 12 Month (0x05h).....	24
Table 13 Year (0x06h).....	24
Table 14 Minutes Alarm (0x07h).....	25
Table 15 Hours Alarm (0x08h).....	25
Table 16 Weekday/Date Alarm (0x09h).....	26
Table 17 Timer Value 0 (0x0Ah).....	27
Table 18 Timer Value 1 (0x0Bh).....	27
Table 19 Timer Status 0 (0x0Ch).....	28
Table 20 Timer Status 1 shadow (0x0Dh).....	28
Table 21 Status (0x0Eh).....	29
Table 22 Control 1 (0x0Fh).....	30
Table 23 Control 2 (0x10h).....	31
Table 24 GP bits (0x11h).....	32
Table 25 Clock Interrupt Mask (0x12h).....	32
Table 26 Event Control (0x13h).....	33
Table 27 Count TS (0x14h).....	34
Table 28 Seconds TS (0x15h).....	34
Table 29 Minutes TS (0x16h).....	34
Table 30 Hours TS (0x17h).....	35
Table 31 Date TS (0x18h).....	35
Table 32 Month TS (0x19h).....	36
Table 33 Year TS (0x1Ah).....	36
Table 34 UNIX Time 0 (0x1Bh).....	37
Table 35 UNIX Time 1 (0x1Ch).....	37
Table 36 UNIX Time 2 (0x1Dh).....	37
Table 37 UNIX Time 3 (0x1Eh).....	37
Table 38 User RAM 1 (0x1Fh).....	38
Table 39 User RAM 2 (0x20h).....	38
Table 40 Password 0 (0x21h).....	39
Table 41 Password 1 (0x22h).....	39
Table 42 Password 2 (0x23h).....	39

Table 43 Password 3 (0x24h).....	39
Table 44 EEPROM Address (0x25h).....	40
Table 45 EEPROM Data (0x26h).....	40
Table 46 EEPROM Commands (0x27h).....	40
Table 47 ID Register (0x28h).....	41
Table 48 EEPROM Reserved (0x2Bh).....	41
Table 49 EEPROM Password Enable (0x30h).....	41
Table 50 EEPROM Password 0 (0x31h).....	42
Table 51 EEPROM Password 1 (0x32h).....	42
Table 52 EEPROM Password 2 (0x33h).....	42
Table 53 EEPROM Password 3 (0x34h).....	42
Table 54 EEPROM FOUT Register (0x35h).....	43
Table 55 EEPROM Offset (0x36h).....	44
Table 56 EEPROM Backup Register (0x37h).....	45
Table 57 EEOffset Value (0x36h, 0x37h).....	46
Table 58 User EEPROM (0x00h to 2Ah).....	46
Table 59 Manufacturer EEPROM (0x2Ch to 2Fh and 38h to 3Fh).....	46
Table 60 Reset Values; RAM (00h to 3Fh).....	47
Table 61 Configuration EEPROM (0x2Bh and 0x30h to 37h).....	48
Table 62 Default values: User EEPROM (0x00h to 2Ah).....	48
Table 63 Default values: Manufacturer EEPROM (0x2Ch to 2Fh and 38h to 3Fh).....	48
Table 64 Component list.....	97
Table 65 Ordering Information.....	99

1. PRODUCT DESCRIPTION

The EM3028 is an extreme-low power CMOS based Real-Time with external 32.768 kHz Crystal. It includes an Automatic Backup switchover function with a Trickle charger where the interrupt output on nINT pin is also working in VBACKUP Power state. The clock output on FOUT pin can be enabled normally via command over interface or can be interrupt driven and synchronized clock output enable/disable on FOUT pin can be freely selected. The configuration registers are stored permanently in non-volatile EEPROM and mirrored in RAM in order that the RTC is still configured correctly even after power down. For safety against inadvertent overwriting the time registers and configuration registers can be protected by a User Programmable Password. Additionally, there is an OscOffset value customer use for aging correction.

The EM3028 provides standard Clock & Calendar function including seconds, minutes, hours (12 or 24 h), weekdays, date, months, years (with leap year correction) and interrupt functions for the Periodic Countdown Timer, Periodic Time Update, Alarm, External Event, Automatic Backup Switchover and Power On Reset. All is accessible via I²C-bus (2-wire Interface). The interrupt functions and the Time Stamp of the External Event function are also working in VBACKUP Power state. Beside the standard RTC functions a 32-bit UNIX Time counter and 43 Bytes of non-volatile User Memory EEPROM and 2 Bytes of User RAM are provided. A further Byte can be used as User RAM when the Periodic Countdown Timer is not used (Timer Value register 0Ah) and a further Byte when the Alarm function is not used (Alarm register 07h).

1.1. BLOCK DIAGRAM

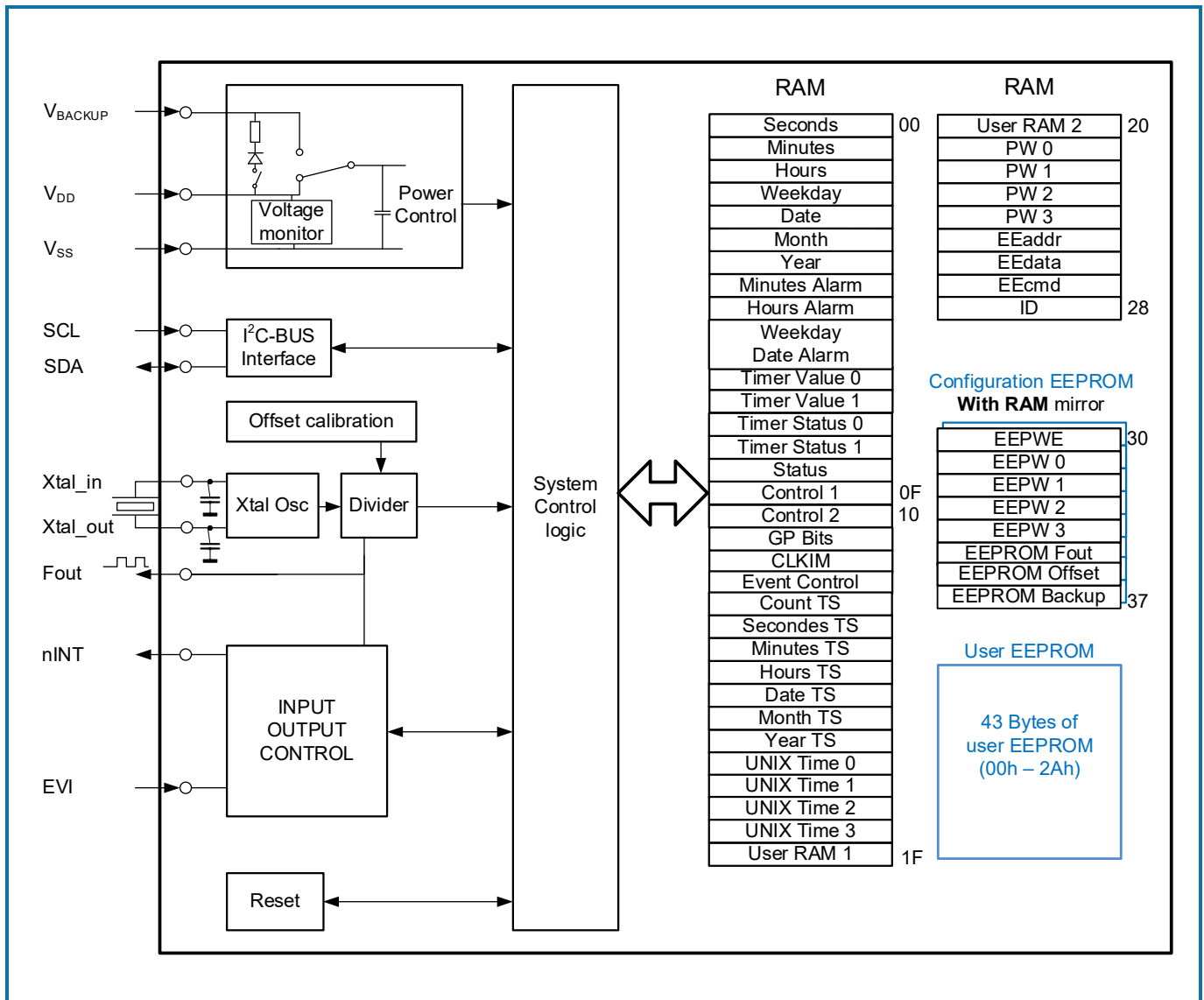


Figure 1-1 EM3028 Block Diagram

1.2. OPERATING MODES

The registers are accessed by selecting a register address and then performing read or write operations. Multiple reads or writes may be executed in a single access, with the address automatically incrementing after each byte. When address is automatically incremented, wrap around occurs from address 3Fh to address 00h (see **Figure 1-2 Address register auto-increment**). All registers are designed as addressable 8-bit registers despite the fact that not all registers and bits are implemented (reserved).

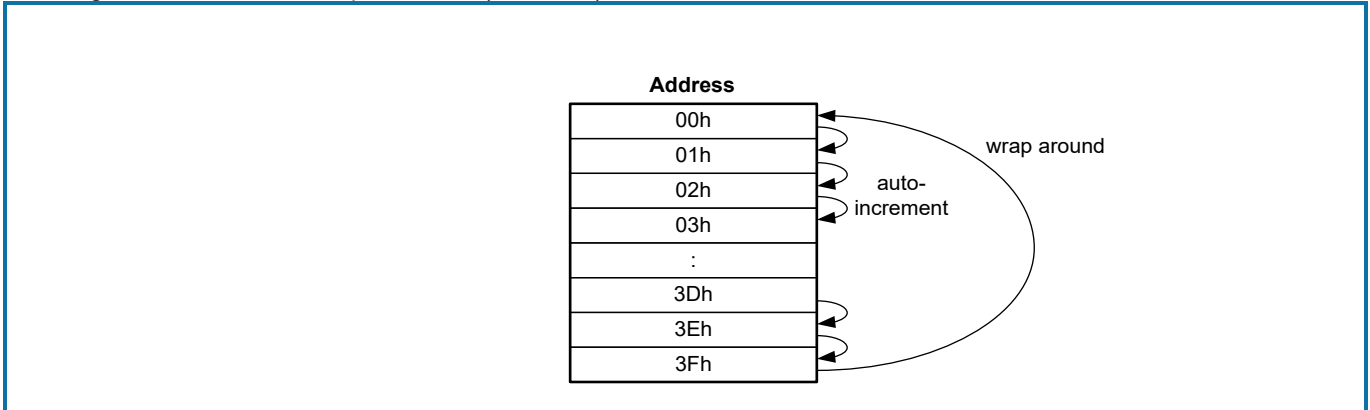


Figure 1-2 Address register auto-increment

1.2.1. DEVICE PROTECTION

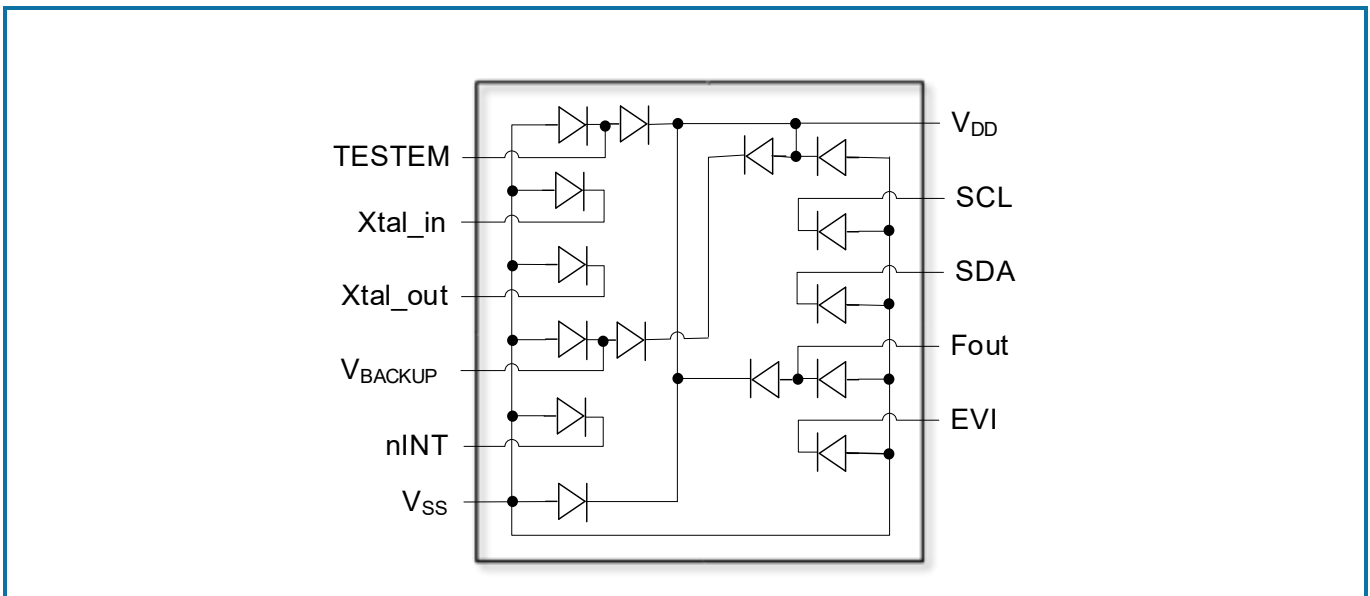


Figure 1-3 Device Diode Protection Diagram

1.2.2. REGISTER ORGANIZATION

- RAM Registers at addresses 00h to 28h are accessed by selecting a register address and then performing read or write operations. Multiple reads or writes may be executed in a single access, with the address automatically incrementing after each byte.
- The Configuration Registers at addresses 2Bh and 30h to 37h are memorized in EEPROM and mirrored in RAM.
- There are 43 bytes of non-volatile user memory EEPROM at addresses 00h to 2Ah for general use.

The following tables summarize the function of each register.

REGISTER CONVENTIONS

The conventions in this table serve as a key for the register overview and individual register diagrams:

Convention (Conv.)	Description
R	Read only. Writing to this register has no effect.
W	Write only. Returns 0 when read.
R/WP	Read: Always readable. Write: Can be write-protected by password.
WP	Write only. It can be write-protected by password.
Prot.	Protected. Not readable, but normal address pointer incrementing.

1.2.3. REGISTER OVERVIEW

After reset, all registers are set according to Table in section **Register Reset Values Summary**.

Register Definitions; RAM, Address 00h to 3Fh:

Address	Function	Conv.	Bit 7	Bit 6	Bit 5	Bit 4	Bit 3	Bit 2	Bit 1	Bit 0
00h	Seconds	R/WP	○	40	20	10	8	4	2	1
01h	Minutes	R/WP	○	40	20	10	8	4	2	1
02h	Hours (24 hour)	R/WP	○	○	20	10	8	4	2	1
	Hours (12 hour)				AMPM	10	8	4	2	1
03h	Weekday	R/WP	○	○	○	○	○	4	2	1
04h	Date	R/WP	○	○	20	10	8	4	2	1
05h	Month	R/WP	○	○	○	10	8	4	2	1
06h	Year	R/WP	80	40	20	10	8	4	2	1
07h	Minutes Alarm	R/WP	AE_M	40	20	10	8	4	2	1
08h	Hours Alarm (24h)	R/WP	AE_H	○	20	10	8	4	2	1
	Hours Alarm (12h)				AMPM	10	8	4	2	1
09h	Weekday Alarm	R/WP	AE_WD	○	○	○	○	4	2	1
	Date Alarm				20	10	8	4	2	1
0Ah	Timer Value 0	R/WP	128	64	32	16	8	4	2	1
0Bh	Timer Value 1	R/WP	○	○	○	○	2048	1024	512	256
0Ch	Timer Status 0	R	128	64	32	16	8	4	2	1
0Dh	Timer Status 1 shadow	R	○	○	○	○	2048	1024	512	256
0Eh	Status	R/WP	EEbusy	CLKF	BSF	UF	TF	AF	EVF	PORF
0Fh	Control 1	R/WP	TRPT	-	WADA	USEL	EERD	TE	TD	
10h	Control 2	R/WP	TSE	CLKIE	UIE	TIE	AIE	EIE	12_24	RESET
11h	GP Bits	R/WP	-	GP6	GP5	GP4	GP3	GP2	GP1	GP0
12h	Clock Int. Mask	R/WP	-	-	-	-	CEIE	CAIE	CTIE	CUIE
13h	Event Control	R/WP	○	EHL	ET		○	TSR	TSOW	TSS
14h	Count TS	R	128	64	32	16	8	4	2	1
15h	Seconds TS	R	○	40	20	10	8	4	2	1
16h	Minutes TS	R	○	40	20	10	8	4	2	1
					AMPM	10	8	4	2	1
17h	Hours TS	R	○	○	20	10	8	4	2	1
18h	Date TS	R	○	○	○	10	8	4	2	1
19h	Month TS	R	○	○	○	10	8	4	2	1
1Ah	Year TS	R	80	40	20	10	8	4	2	1
1Bh	UNIX Time 0	R/WP	UNIX 0 [7:0]							
1Ch	UNIX Time 1	R/WP	UNIX 1 [15:8]							
1Dh	UNIX Time 2	R/WP	UNIX 2 [23:16]							
1Eh	UNIX Time 3	R/WP	UNIX 3 [31:24]							
1Fh	User RAM 1	R/WP	RAM 1 data							
20h	User RAM 2	R/WP	RAM 2 data							
21h	Password 0	W	PW 0 [7:0]							
22h	Password 1	W	PW 1 [15:8]							
23h	Password 2	W	PW 2 [23:16]							

Address	Function	Conv.	Bit 7	Bit 6	Bit 5	Bit 4	Bit 3	Bit 2	Bit 1	Bit 0
24h	Password 3	W	PW 3 [31:24]							
25h	EEPROM Addr.	R/WP	EEaddr							
26h	EEPROM Data	R/WP	EEdata							
27h	EEPROM Com.	WP	EEcmd							
28h	ID	R	HID				VID			
29h and 2Ah	Non-existing		Non-existing RAM address (will be skipped by address pointer)							
2Ch to 2Fh	RESERVED	Prot.	RESERVED (not readable, but normal address pointer incrementing)							
38h to 3Fh	RESERVED	Prot.	RESERVED (not readable, but normal address pointer incrementing)							

o Read only. Always 0.
- Bit not implemented. Will return a 0 when read.

Register Definitions; Configuration EEPROM with RAM mirror, Address 2Bh and 30h to 37h:

Address	Function	Conv.	Bit 7	Bit 6	Bit 5	Bit 4	Bit 3	Bit 2	Bit 1	Bit 0
2Bh	EEPROM RESERVED	R/WP	RESERVED (Must not be overwritten)							
30h	EEPROM PW Enable	R/WP	EEPWE							
31h	EEPROM Password 0	WP	EEPW 0 [7:0]							
32h	EEPROM Password 1	WP	EEPW 1 [15:8]							
33h	EEPROM Password 2	WP	EEPW 2 [23:16]							
34h	EEPROM Password 3	WP	EEPW 3 [31:24]							
35h	EEPROM FOUT	R/WP	CLKOE	CLKSY	-	-	PORIE	FD		
36h	EEPROM Offset	R/WP	EEOffset [8:1]							
37h	EEPROM Backup	R/WP	EEOffset [0]	BSIE	TCE	FEDE	BSM		TCR	

- Bit not implemented. Will return a 0 when read.

Register Definitions; User EEPROM, Address 00h to 2Ah:

Address	Function	Conv.	Bit 7	Bit 6	Bit 5	Bit 4	Bit 3	Bit 2	Bit 1	Bit 0
00h to 2Ah	User EEPROM (43 Bytes)	R/WP	43 Bytes of non-volatile User EEPROM							

Register Definitions; Manufacturer EEPROM, Address 2Ch to 2Fh and 38h to 3Fh:

Address	Function	Conv.	Bit 7	Bit 6	Bit 5	Bit 4	Bit 3	Bit 2	Bit 1	Bit 0
2Ch to 2Fh	EEPROM RESERVED	Prot.	RESERVED							
38h to 3Fh	EEPROM RESERVED	Prot.	RESERVED							

2. HANDLING PROCEDURES

This device has built-in protection against high static voltages or electric fields; however, anti-static precautions must be taken as for any other CMOS component. Unless otherwise specified, proper operation can only occur when all terminal voltages are kept within the voltage range. Unused inputs must always be tied to a defined logic voltage level.

3. PIN DESCRIPTION

PIN		I/O TYPE		DESCRIPTION
NO.	NAME	DIRECTION	SUPPLY	
1	V _{DD}			Positive power supply
2	V _{Backup}			Battery Supply Voltage. When the backup switchover function is not needed, V _{BACKUP} must be tied to V _{SS} with a 10 kΩ resistor.
3	V _{SS}		V _{SS}	Ground
4	TESTEM	I	V _{DD}	Test input for factory test. Connect to V _{SS}
5	Xtal_out	O		Oscillator output Wire length between quartz and package shall be minimized.
6	Xtal_in	I		Oscillator input Wire length between quartz and package shall be minimized.
7	SDA	I/O	V _{DD}	I ² C Serial Data Input-Output; open-drain; requires pull-up resistor. In V _{BACKUP} Power state, the SDA pin is disabled (high impedance).
8	SCL	I	V _{DD}	I ² C Serial Clock Input; requires pull-up resistor. In V _{BACKUP} Power state, the SCL pin is disabled.
9	nINT	O	V _{DD} or V _{BACKUP}	Interrupt Output; open-drain; active LOW; requires pull-up resistor; used to output Periodic Countdown Timer, Periodic Time Update, Alarm, External Event, Automatic Backup Switchover and Power On Reset Interrupt signals. Interrupt output also in V _{BACKUP} Power state.
10	EVI	I	V _{DD} or V _{BACKUP}	External Event Input; used for interrupt generation, interrupt driven clock output and time stamp function. Remains active also in V _{BACKUP} Power state. This pin should not be left floating.
11	FOUT	O	V _{DD}	<p>Clock Output; push-pull; Normal and Interrupt driven clock output can be activated concurrently.</p> <ol style="list-style-type: none"> Normal clock output is controlled by the CLKOE bit. When CLKOE is set to 1 (default), the FOUT pin drives the square wave on the FOUT pin. When CLKOE bit is set to 0, the FOUT pin is LOW. Interrupt driven clock output is controlled by an interrupt event. When CLKIE is set to 1 the occurrence of the interrupt selected in the Clock Interrupt Mask Register (12h) allows the square wave output on the FOUT pin. Writing 0 to CLKIE will disable new interrupts from driving square wave on FOUT. When CLKF flag is cleared, the FOUT pin is LOW. <p>Depending of the settings in the XO field, the FOUT pin can drive the square wave of 32.768 kHz (default), 8192 Hz, 1024 Hz, 64 Hz, 32 Hz or 1 Hz, or the predefined periodic countdown timer interrupt. When XO field is 111 the FOUT pin is LOW.</p> <p>When CLKS_Y bit set to 1, the enabling and disabling of the clock output is synchronized. CLKS_Y has no effect on the timer interrupt signal.</p> <p>In V_{BACKUP} Power state, the FOUT pin is LOW.</p>

Table 1 Pin Out description

4. PACKAGE / PIN OUT / MARKING

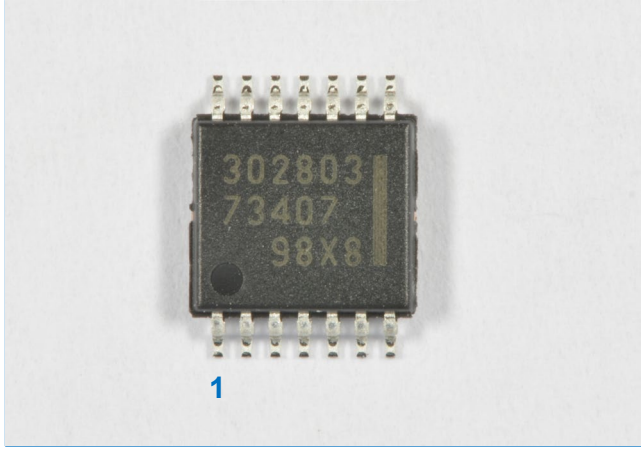
14LD TSSOP: (top view)		NO.	NAME
	1	V _{DD}	
	2	V _{Backup}	
	3	N.C.	
	4	V _{SS}	
	5	TESTEM	
	6	Xtal_out	
	7	Xtal_in	
	8	N.C.	
	9	SDA	
	10	SCL	
	11	nINT	
	12	N.C.	
	13	EVI	
	14	FOUT	

Figure 4-1 14LD TSSOP

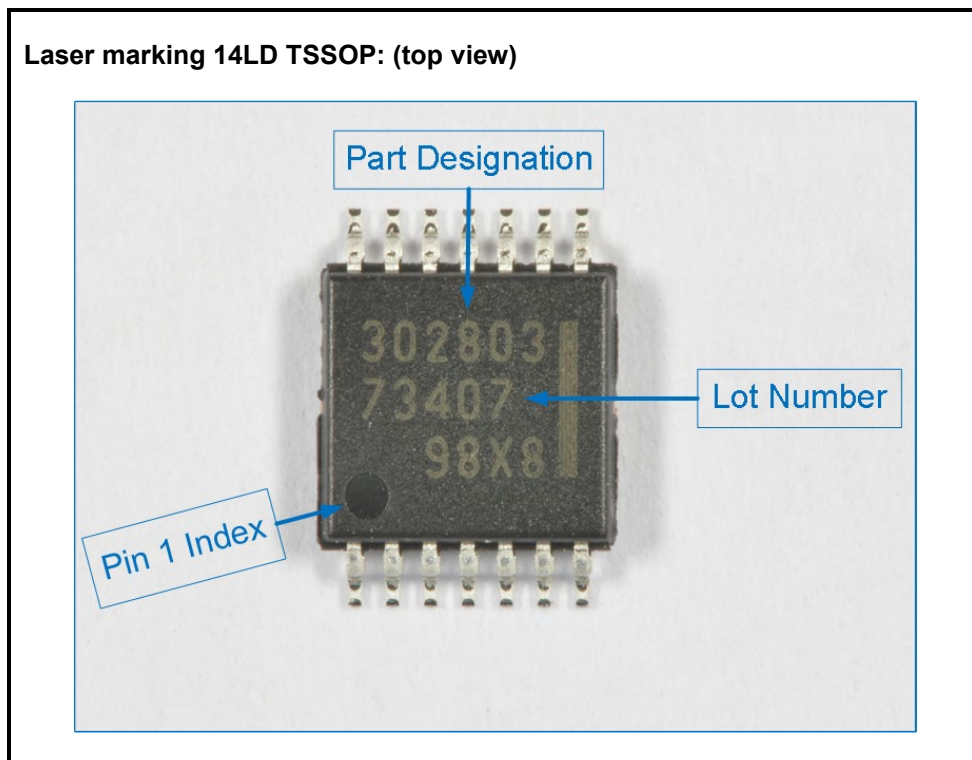


Figure 4-2 Laser marking 14LD TSSOP

5. ELECTRICAL SPECIFICATIONS

5.1. ABSOLUTE MAXIMUM RATINGS

PARAMETER	VALUE		UNIT
	MIN	MAX	
Power supply V_{DD}	-0.3	+6.0	V
Storage Temperature Range (T_{STG})	-50	+150	°C
Electrostatic discharge to ANSI/ESDA/JEDEC JS-001 for HBM	-2000	+2000	V
Latch-up testing, according to JESD78., Class I (room temperature), level A (100)	-100	+100	mA

Table 2 Absolute maximum ratings

Stresses above these listed maximum ratings may cause permanent damages to the device. Exposure beyond specified operating conditions may affect device reliability or cause malfunction.

Warning: The device is not functional when exposed to light. When a non-packaged version is used, it is mandatory to protect the device from light.

5.2. OPERATING CONDITIONS

PARAMETER	SYMBOL	MIN	TYP	MAX	UNIT
Supply voltage	V_{DD}	1.1		5.5	V
Battery Supply voltage	V_{BACKUP}	1.1		5.5	V
Temperature range	T_R	-40		+85	°C

Table 3 Operating Conditions

5.3. ELECTRICAL CHARACTERISTICS

Unless otherwise specified: $V_{DD} = 1.2$ to $5.5V$, $T_A = -40$ to $+85^\circ C$ for min max specifications and $T_A = 25^\circ C$, $V_{DD} = 3.0V$, $R_s = 40k\Omega$ for typical specifications.

PARAMETER	SYMBOL	CONDITIONS	MIN	TYP	MAX	UNIT
SUPPLIES						
Power Supply Voltage	V_{DD}	Time-keeping mode ⁽¹⁾	1.1		5.5	V
		I ² C-bus (100 kHz)	1.2		5.5	
		I ² C-bus (400 kHz)	2.0		5.5	
Backup Supply Voltage	V_{BACKUP}		1.1		5.5	V
V_{DD} supply current timekeeping I ² C-bus inactive, FOUT disabled, average current	I_{VDD}	$V_{DD} = 1.1 V$ ⁽²⁾		45	300	nA
		$V_{DD} = 3.0 V$ ⁽²⁾		45	330	
		$V_{DD} = 5.0 V$ ⁽²⁾		45	400	
V_{DD} supply current during I ² C burst read/write, FOUT disabled	$I_{VDD:I2C}$	$V_{DD} = 1.2 V$, SCL = 100 kHz ⁽³⁾		2	15	μA
		$V_{DD} = 3.0 V$, SCL = 400 kHz ⁽³⁾		5	40	
		$V_{DD} = 5.0 V$, SCL = 400 kHz ⁽³⁾		7	60	
V_{DD} supply current in level switching mode I ² C-bus inactive, FOUT disabled	$I_{VDD:LEVEL}$	$V_{DD} = 3.0 V$, $T_A = 25^\circ C$		115	180	nA
V_{DD} supply current in direct switching mode I ² C-bus inactive, FOUT disabled	$I_{VDD:DIRECT}$	$V_{DD} = 3.0 V$, $T_A = 25^\circ C$		95	150	nA
Additional V_{DD} supply current ⁽⁴⁾	$\Delta I_{VDD:CK32}$	$V_{DD} = 3.0 V$, $F_{OUT} = 32.768 kHz$, $C_L = 10 pF$		1		μA
	$\Delta I_{VDD:CK1024}$	$V_{DD} = 3.0 V$, $F_{OUT} = 1024 Hz$, $C_L = 10 pF$		30		nA
	$\Delta I_{VDD:CK1}$	$V_{DD} = 3.0 V$, $F_{OUT} = 1 Hz$, $C_L = 10 pF$		0.03		nA

(1) Clocks operating and RAM registers retained.
(2) All inputs and outputs are at 0 V or V_{DD} .
(3) 2.2k pull-up resistors on SCL/SDA, excluding external peripherals and pull-up resistor current. All other inputs (besides SDA and SCL) are at 0 V or V_{DD} . Test conditions: Continuous burst read/write, 55h data pattern, 25 μs between each data byte, 20 pF load on each bus pin.
(4) When FOUT is enabled the additional V_{DD} supply current ΔI_{VDD} can be calculated as follows:
 $\Delta I_{VDD} = C_L \times V_{DD} \times f_{OUT}$, e.g. $\Delta I_{VDD} = 10 pF \times 3.0 V \times 32.768 Hz = 980 nA \approx 1 \mu A$

Table 4 Electrical Specifications

Typical characteristics in direct switching mode: $I_{VDD:LEVEL}@ V_{DD} = 2.1 V$ and $I_{VBACKUP}$ vs. V_{BACKUP} , $T_A = 25^\circ C$, I²C-bus inactive, FOUT disabled.

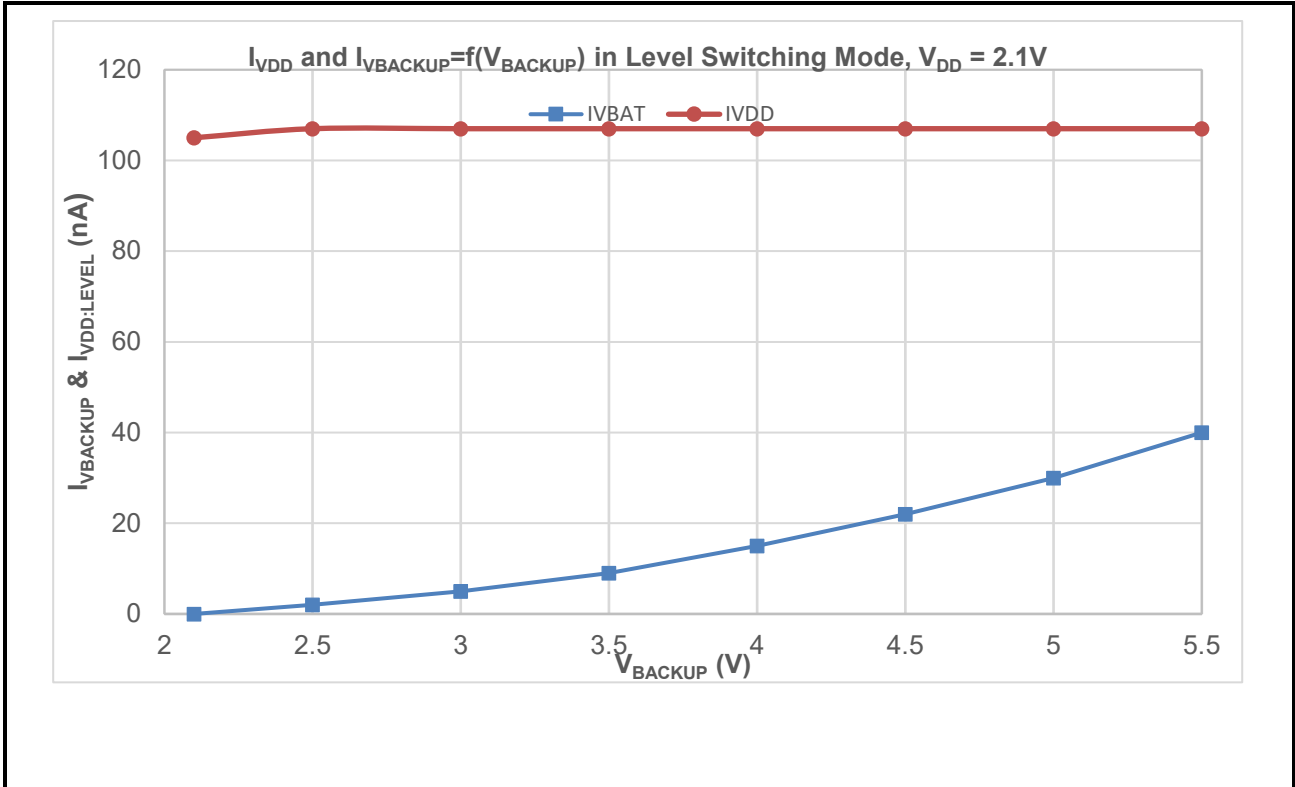


Figure 5-1 Battery Consumption, $T_{OPR} = 25^{\circ}C$, $V_{DD} = 2.1V$, $V_{DD} > V_{th_swbat}$, Level Switching

Unless otherwise specified: $V_{DD} = 1.2$ to $5.5V$, $T_A = -40$ to $+85^\circ C$ for min max specifications and $T_A = 25^\circ C$, $V_{DD} = 3.0V$, $R_s = 40k\Omega$ for typical specifications.

PARAMETER	SYMBOL	CONDITIONS	MIN	TYP	MAX	UNIT
INPUTS						
LOW level input voltage	V_{IL}	$V_{DD} = 1.1V$ to $5.5V$			$0.2 V_{DD}$	V
HIGH level input voltage	V_{IH}	Pins: SCL, SDA, EVI	$0.8 V_{DD}$			V
Input leakage current	I_{ILEAK}	$V_{SS} \leq V_I \leq V_{DD}$	-0.5		0.5	μA
Input capacitance	C_I	$V_{DD} = 3.0V$, $T_A = 25^\circ C$ $f = 1MHz$			7	pF
Outputs						
LOW level output voltage FOUT	$V_{OL:CLK}$	$V_{DD} = 1.1V$, $I_{OL} = -0.1mA$ $V_{DD} = 3.0V$, $I_{OL} = -1.0mA$ $V_{DD} = 5.0V$, $I_{OL} = -1.0mA$			0.1 0.3 0.5	V
HIGH level output voltage FOUT	$V_{OH:CLK}$	$V_{DD} = 1.1V$, $I_{OH} = 0.1mA$ $V_{DD} = 3.0V$, $I_{OH} = 1.0mA$ $V_{DD} = 5.0V$, $I_{OH} = 1.0mA$	1.0 2.7 4.5			V
LOW level output voltage Pins: SDA, nINT	V_{OL}	$V_{DD} = 1.2V$, $I_{OL} = -0.5mA$ $V_{DD} = 3.0V$, $I_{OL} = -3.0mA$ $V_{DD} = 5.0V$, $I_{OL} = -3.0mA$			0.4 0.4 0.3	V
Output leakage current	I_{OLEAK}	$V_O = V_{DD}$ or V_{SS}	-0.5		0.5	μA
Output capacitance	C_{OUT}	$V_{DD} = 3.0V$, $T_A = 25^\circ C$ $f = 1MHz$			7	pF
Power On Reset						
POR detection threshold	V_{POR}		0.75	0.8	0.85	V
Trickle charger						
Current limiting resistors	TCR 1 k Ω	$V_{DD} = 5.0V$, $V_{BACKUP} = 3.0V$, including internal schottky diode	2	3	4	k Ω
	TCR 3 k Ω		4.5	5.5	6.25	
	TCR 6 k Ω		7.5	9.3	11.6	
	TCR 11 k Ω		12.5	15.7	17.4	
Switchover						
Switchover hysteresis in direct switching mode	$V_{HYST:DSM}$	V_{DD} with respect to $V_{BACKUP} = 3.0V$, $T_{OPR} = -40^\circ C$ to $+85^\circ C$		60		mV
Backup switchover threshold voltage	V_{DDSW}	Relative to V_{DD}	1.8	2.0	2.2	V
Switchover hysteresis in level switching mode	$V_{HYST:LSM}$	V_{DD} with respect to $V_{BACKUP} = 3.0V$, $T_{OPR} = -40^\circ C$ to $+85^\circ C$		100		mV
EEPROM Characteristics						
Read voltage	V_{READ}		1.1			V
Programming voltage	V_{PROG}		1.5			
Write voltage, only for voltage $\geq V_{DDSW}$	V_{WRITE}		V_{DDSW}			
EEPROM programming time 1 byte	T_{PROG}		4		30	ms
Write / erase cycles			100		10'000	cycle

5.4. OSCILLATOR CHARACTERISTICS

Unless otherwise specified: $V_{DD} = 1.2$ to $5.5V$, $T_A = -40$ to $+85^\circ C$ for min max specifications and $T_A = 25^\circ C$, $V_{DD} = 3.0V$, $R_s = 40k\Omega$ for typical specifications.

PARAMETER	SYMBOL	CONDITIONS	MIN	TYP	MAX	UNIT
XTAL GENERAL						
Crystal Frequency	F			32.768		kHz
Oscillator start-up time at $V_{DD} = 3.0 V$	t_{START}	$T_A = 25^\circ C$		0.5	1	s
Oscillator start-up voltage	V_{START}	$T_A = 25^\circ C$			3	s
Frequency vs. voltage Characteristics	$\Delta f/V$	$V_{DD} = 1.1 V$ to $5.5 V$ $T_A = 25^\circ C$		0.5		ppm/V
V_{DD} rising slew rate	V_{DDR}	$V_{DD} = 1.1 V$ to $3.6 V$ $V_{DD} = 3.6 V$ to $5.5 V$			2.5 3.8	V/ms
V_{DD} falling slew rate	V_{DDF}	$V_{DD} = 5.5 V$ to $1.1 V$			2.2	V/ms
FOUT duty cycle	ΔF_{OUT}	$V_{DD} = 1.1 V$ to $5.5 V$, $F_{OUT} = 32.768 kHz$	40	50	60	%
XTAL FREQUENCY CHARACTERISTICS						
Frequency accuracy	$\Delta F/F$	$T_A = 25^\circ C$		± 5		ppm
Frequency vs. temperature characteristics	$\Delta F/F_{TOPR}$	$T_{OPR} = -40^\circ C$ to $+85^\circ C$ $V_{DD} = 3.0 V$		$-0.035 ppm/^\circ C^2 (T_{OPR} - T_0)^2 \pm 10\%$		ppm
Turnover temperature	T_0			$+25 \pm 5$		$^\circ C$
Aging first year max.	$\Delta F/F$	$T_A = 25^\circ C$, $V_{DD} = 3.0 V$			± 3	ppm
FREQUENCY OFFSET CORRECTION						
OFFSET correction: Min. corr. step (LSB) and Max. corr. Range	$\Delta t/t$	$T_A = -40^\circ C$ to $+85^\circ C$	± 0.954		$+243.2 / -244.1$	ppm
Achievable time accuracy	$\Delta t/t$	Calibrated at an initial temperature and voltage	-0.48		+0.48	ppm

Integrated C_{XTAL_in} and C_{XTAL_out} tolerance: $C_{XTAL_min} = (0.9 * C_{XTAL_typ}) - 0.5$
 $C_{XTAL_max} = (1.1 * C_{XTAL_typ}) + 0.5$

Integrated load capacitance, C_L , is a calculation of C_{XTAL_in} and C_{XTAL_out} in series: $C_L = \frac{(C_{XTAL_in} * C_{XTAL_out})}{(C_{XTAL_in} + C_{outXTAL_out})}$

Crystal Reference : Micro Crystal CM7V-T1A

web: www.microcrystal.com

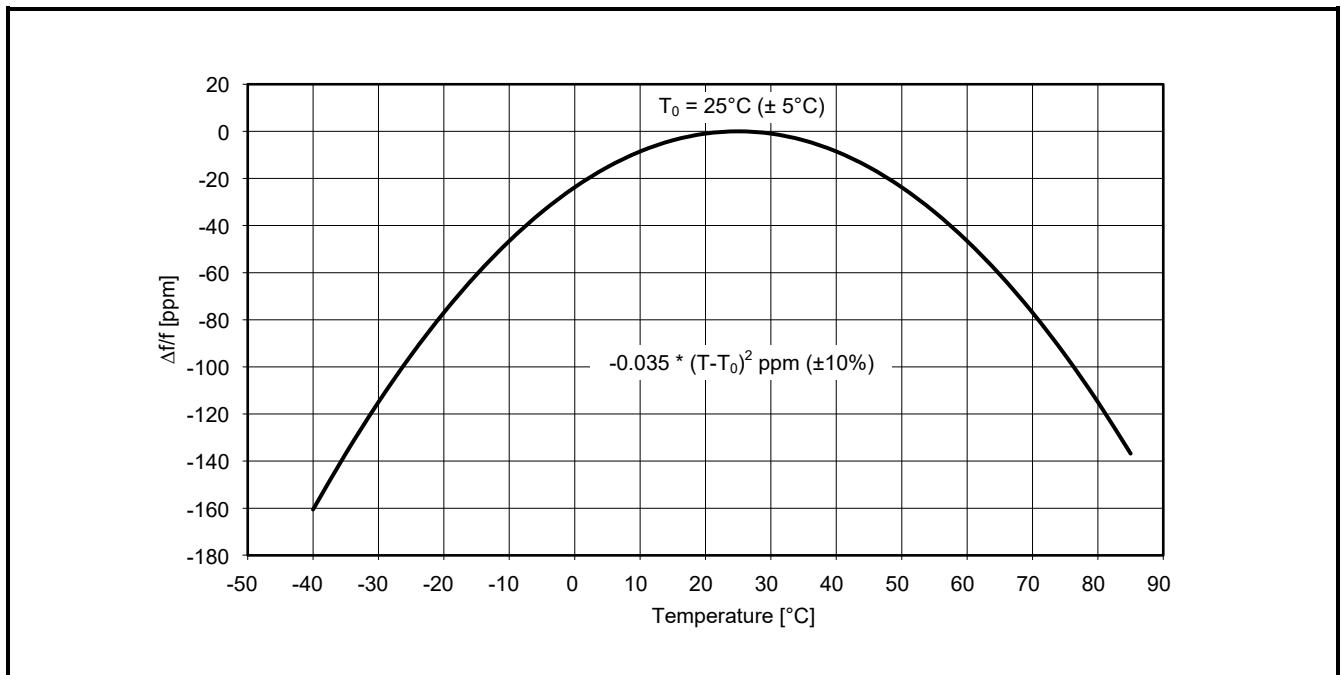


Figure 5-2 XTAL Frequency vs Temperature Characteristics

5.5. TIMING CHARACTERISTICS

Unless otherwise specified: VDD = 1.2 to 5.5V, TA=-40 to +85°C for min max specifications and TA= 25°C and 3.0V for typical specifications

PARAMETER	SYMBOL	CONDITIONS	MIN	TYP	MAX	UNIT
VDD rising slew rate at initial power on reset (POR)	V _{DDR1}	FOUT enabled (CLKOE = 1)	0.1		1	V/ms
Oscillator start-up time at V _{DD} = 3.0 V	t _{START}		0.5	3	s	
First refreshment time	t _{REFR}		66		ms	

Table 5 Timing Characteristics

5.5.1. POWER ON

The following Figure describes the power on AC electrical characteristics for the FOUT pin. The clock output signal on FOUT pin is enabled by the CLKOE bit (EEPROM 35h), see also **Use of the Configuration EEPROM WITH RAM MIRROR Registers.**

Power On AC Electrical Characteristics:

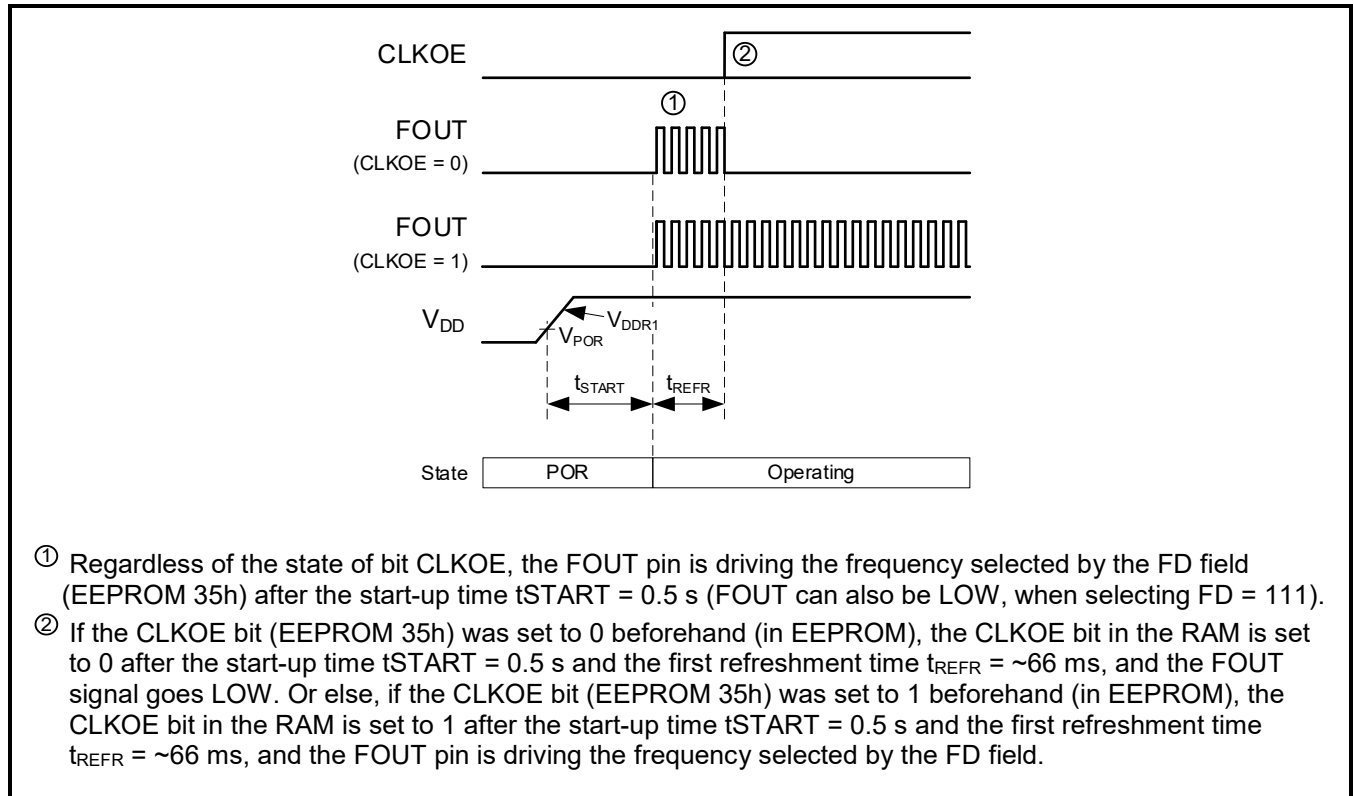


Figure 5-3 Power On Timing Diagram

5.5.2. I²C-BUS CHARACTERISTICS

The following Figure and Table describe the I²C AC electrical parameters.

I²C AC Parameter Definitions:

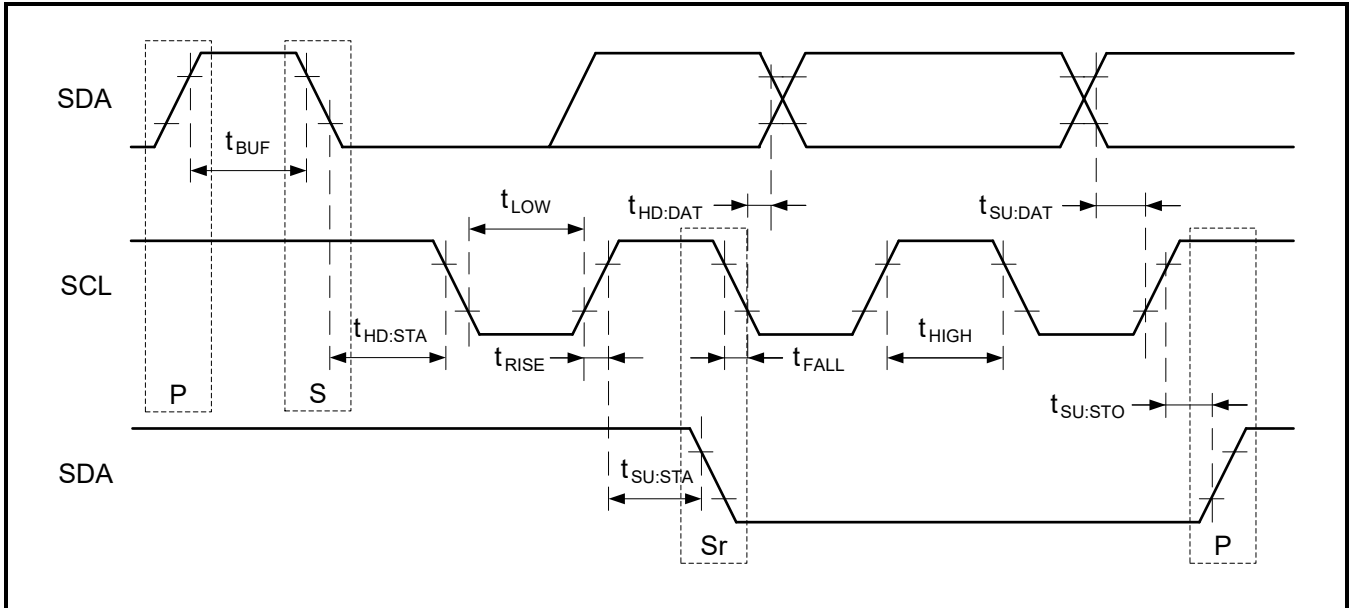


Figure 5-4 I²C BUS Timing Diagram

PARAMETER	SYMBOL	CONDITIONS	MIN	TYP	MAX	UNIT
SCL input clock frequency	f _{SCL}	V _{DD} ≥ 1.2 V	0		100	kHz
		V _{DD} ≥ 2.0 V	0		400	
Low period of SCL clock	t _{LOW}	V _{DD} ≥ 1.2 V	4.7			μs
		V _{DD} ≥ 2.0 V	1.3			
High period of SCL clock	t _{HIGH}	V _{DD} ≥ 1.2 V	4.0			μs
		V _{DD} ≥ 2.0 V	0.6			
Rise time of SDA and SCL	t _{RISE}	V _{DD} ≥ 1.2 V			1000	ns
		V _{DD} ≥ 2.0 V			300	
Fall time of SDA and SCL	t _{FALL}	V _{DD} ≥ 1.2 V			300	ns
		V _{DD} ≥ 2.0 V			300	
START condition hold time	t _{HD:STA}	V _{DD} ≥ 1.2 V	4.0			μs
		V _{DD} ≥ 2.0 V	0.6			
START condition setup time	t _{SU:STA}	V _{DD} ≥ 1.2 V	4.7			μs
		V _{DD} ≥ 2.0 V	0.6			
SDA setup time	t _{SU:DAT}	V _{DD} ≥ 1.2 V	250			ns
		V _{DD} ≥ 2.0 V	100			
SDA hold time	t _{HD:DAT}	V _{DD} ≥ 1.2 V	0			μs
		V _{DD} ≥ 2.0 V	0			
STOP condition setup time	t _{SU:STO}	V _{DD} ≥ 1.2 V	4.0			μs
		V _{DD} ≥ 2.0 V	0.6			
Bus free time before a new transmission	t _{BUF}	V _{DD} ≥ 1.2 V	4.7			μs
		V _{DD} ≥ 2.0 V	1.3			

S = Start condition, Sr = Repeated Start condition, P = Stop condition

Table 6 5 I²C Timing Characteristics

Caution:

When accessing the EM3028, all communication from transmitting the Start condition to transmitting the Stop condition after access should be completed within 950 ms.

If such communication requires 950 ms or longer, the I²C bus interface is reset by the internal bus timeout function.

6. PRODUCT CONFIGURATION

6.1. CLOCK REGISTERS

00h – Seconds. This register holds the count of seconds, in two binary coded decimal (BCD) digits. Values will be from 00 to 59. Read: Always readable. Write: Can be write-protected by password.

Address	Function	Conv.	Bit 7	Bit 6	Bit 5	Bit 4	Bit 3	Bit 2	Bit 1	Bit 0
00h	Seconds	R/WP	○	40	20	10	8	4	2	1
	Reset		0	0	0	0	0	0	0	0
Bit	Symbol	Value	Description							
7	○	0	Read only. Always 0.							
6:0	Seconds	00 to 59	Holds the count of seconds, coded in BCD format. When 1 is written to the RESET bit the Seconds register value remains unchanged.							

Table 7 Seconds (0x00h).

01h – Minutes. This register holds the count of minutes, in two binary coded decimal (BCD) digits. Values will be from 00 to 59. Read: Always readable. Write: Can be write-protected by password.

Address	Function	Conv.	Bit 7	Bit 6	Bit 5	Bit 4	Bit 3	Bit 2	Bit 1	Bit 0
01h	Minutes	R/WP	○	40	20	10	8	4	2	1
	Reset		0	0	0	0	0	0	0	0
Bit	Symbol	Value	Description							
7	○	0	Read only. Always 0.							
6:0	Minutes	00 to 59	Holds the count of minutes, coded in BCD format.							

Table 8 Minutes (0x01h).

02h – Hours. This register holds the count of hours, in two binary coded decimal (BCD) digits. If the 12_24 bit is cleared (default) (see [Configuration Registers](#), 10h – Control 2) the values will be from 0 to 23. If the 12_24 bit is set, the hour values will range from 1 to 12 and the AMPM bit will be 0 for AM hours and 1 for PM hours. Read: Always readable. Write: Can be write-protected by password.

Address	Function	Conv.	Bit 7	Bit 6	Bit 5	Bit 4	Bit 3	Bit 2	Bit 1	Bit 0
02h	Hours (24 hour mode) – default value	R/WP	○	○	20	10	8	4	2	1
	Hours (12 hour mode)				AMPM	10	8	4	2	1
	Reset		0	0	0	0	0	0	0	0
Hours (24 hour mode), 12_24 = 0 – default value										
Bit	Symbol	Value	Description							
7:6	○	0	Read only. Always 0.							
5:0	Hours (24 hour mode) – default value	0 to 23	Holds the count of hours, coded in BCD format.							
Hours (12 hour mode), 12_24 = 1										
Bit	Symbol	Value	Description							
7:6	○	0	Read only. Always 0.							
5	AMPM	0	AM hours.							
		1	PM hours.							
4:0	Hours (12 hour mode)	1 to 12	Holds the count of hours, coded in BCD format.							

Table 9 Hours (0x02h).

6.2. CALENDAR REGISTERS

03h – Weekday. This register holds the current day of the week. Each value represents one weekday that is assigned by the user. Values will range from 0 to 6. Read: Always readable. Write: Can be write-protected by password.

Address	Function	Conv.	Bit 7	Bit 6	Bit 5	Bit 4	Bit 3	Bit 2	Bit 1	Bit 0
03h	Weekday	R/WP	○	○	○	○	○	4	2	1
	Reset		0	0	0	0	0	0	0	0
Bit	Symbol	Value	Description							
7:3	○	0	Read only. Always 0.							
2:0	Weekday	0 to 6	Holds the weekday counter value.							
Weekday			Bit 7	Bit 6	Bit 5	Bit 4	Bit 3	Bit 2	Bit 1	Bit 0
Weekday 1 – Default value			0	0	0	0	0	0	0	0
Weekday 2								0	0	1
Weekday 3								0	1	0
Weekday 4								0	1	1
Weekday 5								1	0	0
Weekday 6								1	0	1
Weekday 7								1	1	0

Table 10 Weekday (0x03h).

04h – Date. This register holds the current day of the month, in two binary coded decimal (BCD) digits. Values will range from 01 to 31. Leap years are correctly handled from 2000 to 2099. Read: Always readable. Write: Can be write-protected by password.

Address	Function	Conv.	Bit 7	Bit 6	Bit 5	Bit 4	Bit 3	Bit 2	Bit 1	Bit 0
04h	Date	R/WP	○	○	20	10	8	4	2	1
	Reset		0	0	0	0	0	0	0	1
Bit	Symbol	Value	Description							
7:6	○	0	Read only. Always 0.							
5:0	Date	01 to 31	Holds the current date of the month, coded in BCD format. – Default value = 01							

Table 11 Date (0x04h).

05h – Month. This register holds the current month, in two binary coded decimal (BCD) digits. Values will range from 01 to 12. Read: Always readable. Write: Can be write-protected by password.

Address	Function	Conv.	Bit 7	Bit 6	Bit 5	Bit 4	Bit 3	Bit 2	Bit 1	Bit 0
05h	Month	R/WP	○	○	○	10	8	4	2	1
	Reset		0	0	0	0	0	0	0	1
Bit	Symbol	Value	Description							
7:5	○	0	Read only. Always 0.							
4:0	Month	01 to 12	Holds the current month, coded in BCD format.							
Months			Bit 7	Bit 6	Bit 5	Bit 4	Bit 3	Bit 2	Bit 1	Bit 0
January – Default value			0	0	0	0	0	0	0	1
February						0	0	0	1	0
March						0	0	0	1	1
April						0	0	1	0	0
May						0	0	1	0	1
June						0	0	1	1	0
July						0	0	1	1	1
August						0	1	0	0	0
September						0	1	0	0	1
October						1	0	0	0	0
November						1	0	0	0	1
December						1	0	0	1	0

Table 12 Month (0x05h).

06h – Year. This register holds the current year, in two binary coded decimal (BCD) digits. Values will range from 00 to 99. Leap years are correctly handled from 2000 to 2099. Read: Always readable. Write: Can be write-protected by password.

Address	Function	Conv.	Bit 7	Bit 6	Bit 5	Bit 4	Bit 3	Bit 2	Bit 1	Bit 0
06h	Year	R/WP	80	40	20	10	8	4	2	1
	Reset		0	0	0	0	0	0	0	0
Bit	Symbol	Value	Description							
7:0	Year	00 to 99	Holds the current year, coded in BCD format. – Default value = 00							

Table 13 Year (0x06h)

6.3. ALARM REGISTERS

07h – Minutes Alarm. This register holds the Minutes Alarm Enable bit AE_M and the alarm value for minutes, in two binary coded decimal (BCD) digits. Values will range from 00 to 59. Read: Always readable. Write: Can be write-protected by password.

Address	Function	Conv.	Bit 7	Bit 6	Bit 5	Bit 4	Bit 3	Bit 2	Bit 1	Bit 0
07h	Minutes Alarm	R/WP	AE_M	40	20	10	8	4	2	1
	Reset		1	0	0	0	0	0	0	0

Bit	Symbol	Value	Description
7	AE_M		Minutes Alarm Enable bit. Enables alarm together with AE_H and AE_WD (see Use of The Alarm Interrupt).
		0	Minutes Alarm is enabled.
		1	Minutes Alarm is disabled. – Default value
6:0	Minutes Alarm	00 to 59	Holds the alarm value for minutes, coded in BCD format.

Table 14 Minutes Alarm (0x07h).

08h – Hours Alarm. This register holds the Hours Alarm Enable bit AE_H and the alarm value for hours, in two binary coded decimal (BCD) digits. If the 12_24 bit is cleared (default value) (see [Configuration Registers](#), 10h – Control 2) the values will range from 0 to 23. If the 12_24 bit is set, the hour values will be from 0 to 12 and the AMPM bit will be 0 for AM hours and 1 for PM hours. Read: Always readable. Write: Can be write-protected by password.

Address	Function	Conv.	Bit 7	Bit 6	Bit 5	Bit 4	Bit 3	Bit 2	Bit 1	Bit 0
08h	Hours Alarm (24 hour mode) – default value	R/WP	AE_H	○	20	10	8	4	2	1
	Hours Alarm (12 hour mode)				AMPM	10	8	4	2	1
	Reset		1	0	0	0	0	0	0	0

Hours Alarm (24 hour mode), 12_24 = 0 – default value			
Bit	Symbol	Value	Description
7	AE_H		Hours Alarm Enable bit (see Use of The Alarm Interrupt).
		0	Enabled
		1	Disabled – Default value
6	○	0	Read only. Always 0.
5:0	Hours Alarm (24 hour mode) – default value	0 to 23	Holds the alarm value for hours, coded in BCD format.

Hours Alarm(12 hour mode), 12_24 = 1			
Bit	Symbol	Value	Description
7	AE_H		Hours Alarm Enable bit (see Use of The Alarm Interrupt).
		0	Enabled
		1	Disabled – Default value
6	○	0	Read only. Always 0.
5	AMPM	0	AM hours.
		1	PM hours.
4:0	Hours Alarm (12 hour mode)	1 to 12	Holds the alarm value for hours, coded in BCD format.

Table 15 Hours Alarm (0x08h).

09h – Weekday/Date Alarm. This register holds the Weekday/Date Alarm Enable bit AE_WD. If the WADA bit is 0 (Bit 5 in Register 0Fh), it holds the alarm value for the weekday (weekdays assigned by the user), in two binary coded decimal (BCD) digits. Values will range from 0 to 6. If the WADA bit is 1, it holds the alarm value for the date, in two binary coded decimal (BCD) digits. Values will range from 01 to 31. Leap years are correctly handled from 2000 to 2099. Read: Always readable. Write: Can be write-protected by password.

Address	Function	Conv.	Bit 7	Bit 6	Bit 5	Bit 4	Bit 3	Bit 2	Bit 1	Bit 0
09h	Weekday Alarm – default value	R/WP	AE_WD	○	○	○	○	4	2	1
	Date Alarm				20	10	8	4	2	1
	Reset	1	0	0	0	0	0	0	0	0
Weekday Alarm, WADA = 0 – default value										
Bit	Symbol	Value	Description							
7	AE_WD	Weekday/Date Alarm Enable bit. Enables alarm together with AE_M and AE_H (see Use of The Alarm Interrupt).								
		0	Enabled							
		1	Disabled – Default value							
6:3	○	0	Read only. Always 0.							
2:0	Weekday Alarm	0 to 6	Holds the weekday alarm value, coded in BCD format.							
Date Alarm, WADA = 1										
Bit	Symbol	Value	Description							
7	AE_WD	Weekday/Date Alarm Enable bit. Enables alarm together with AE_M and AE_H (see Use of The Alarm Interrupt).								
		0	Enabled							
		1	Disabled – Default value							
6	○	0	Read only. Always 0.							
5:0	Date Alarm	01 to 31	Holds the alarm value for the date, coded in BCD format. The Reset value 00 after POR has to be replaced by a valid value (01 to 31).							

Table 16 Weekday/Date Alarm (0x09h).

6.4. PERIODIC COUNTDOWN TIMER CONTROL REGISTERS

0Ah – Timer Value 0. This register is used to set the lower 8 bits of the Timer Value (preset value) for the Periodic Countdown Timer. This value will be reloaded into the Countdown Timer when it reaches zero if the TRPT bit is 1. This allows for periodic timer interrupts (see calculation below). Read: Always readable. Write: Can be write-protected by password.

Address	Function	Conv.	Bit 7	Bit 6	Bit 5	Bit 4	Bit 3	Bit 2	Bit 1	Bit 0
0Ah	Timer Value 0	R/WP	128	64	32	16	8	4	2	1
	Reset		0	0	0	0	0	0	0	0
Bit	Symbol	Value	Description							
7:0	Timer Value 0	00h to FFh	The Timer Value for the Periodic Countdown Timer in binary format (lower 8 bit) (see Use of the Periodic Countdown Timer Interrupt). When read, only the preset value is returned and not the actual value. When the Periodic Countdown Timer Interrupt function is not used, register 0Ah can be used as RAM byte.							

Table 17 Timer Value 0 (0x0Ah).

0Bh – Timer Value 1. This register is used to set the upper 4 bits of the Timer Value (preset value) for the Periodic Countdown Timer. This value will be reloaded into the Countdown Timer when it reaches zero if the TRPT bit is a 1. This allows for periodic timer interrupts (see calculation below). Read: Always readable. Write: Can be write-protected by password.

Address	Function	Conv.	Bit 7	Bit 6	Bit 5	Bit 4	Bit 3	Bit 2	Bit 1	Bit 0
0Bh	Timer Value 1	R/WP	○	○	○	○	2048	1024	512	256
	Reset		0	0	0	0	0	0	0	0
Bit	Symbol	Value	Description							
7:4	○	0	Read only. Always 0.							
3:0	Timer Value 1	0h to Fh	The Timer Value for the Periodic Countdown Timer in binary format (upper 4 bit) (see Use of the Periodic Countdown Timer Interrupt). When read, only the preset value is returned and not the actual value.							

Table 18 Timer Value 1 (0x0Bh).

Countdown Period in seconds:

$$\text{Countdown Period} = \frac{\text{Timer Value}}{\text{Timer Clock Frequency}}$$

0Ch – Timer Status 0. This register holds the lower 8 bits of the current value of the Periodic Countdown Timer. It is read only. Writing to this register has no effect.

Address	Function	Conv.	Bit 7	Bit 6	Bit 5	Bit 4	Bit 3	Bit 2	Bit 1	Bit 0
0Ah	Timer Value 0	R/WP	128	64	32	16	8	4	2	1
	Reset		0	0	0	0	0	0	0	0
Bit	Symbol	Value	Description							
7:0	Timer Value 0	00h to FFh	The Timer Value for the Periodic Countdown Timer in binary format (lower 8 bit) (see Use of the Periodic Countdown Timer Interrupt). When read, only the preset value is returned and not the actual value. When the Periodic Countdown Timer Interrupt function is not used, register 0Ah can be used as RAM byte.							

Table 19 Timer Status 0 (0x0Ch).

0Dh – Timer Status 1 shadow. This register holds the upper 4 bits of the current value of the Periodic Countdown Timer. It is read only. Writing to this register has no effect.

Address	Function	Conv.	Bit 7	Bit 6	Bit 5	Bit 4	Bit 3	Bit 2	Bit 1	Bit 0
0Dh	Timer Status 1	R	○	○	○	○	2048	1024	512	256
	Reset		0	0	0	0	0	0	0	0
Bit	Symbol	Value	Description							
7:4	○	0	Read only. Always 0.							
3:0	Timer Status 1	0h to Fh	The current value of the Periodic Countdown Timer in binary format (upper 4 bit) (see Use of the Periodic Countdown Timer Interrupt).							

Table 20 Timer Status 1 shadow (0x0Dh).

When TE bit is set to 1, reading the Timer Status 0 value updates the Timer Status 1 shadow register. Reading Timer Status 1 will return the Timer Status 1 shadow register value, memorized during Timer Status 0 read. When a 0 is written to the TE bit, the Timer Status 0 and Timer Status 1 registers store the last updated value.

6.5. CONFIGURATION REGISTERS

0Eh – Status. This register is used to detect the occurrence of various interrupt events and reliability problems in internal data. Read: Always readable. Write: Can be write-protected by password.

Address	Function	Conv.	Bit 7	Bit 6	Bit 5	Bit 4	Bit 3	Bit 2	Bit 1	Bit 0		
0Eh	Status	R/WP	EEbusy	CLKF	BSF	UF	TF	AF	EVF	PORF		
	Reset		1 → 0	0	0	0	0	0	X	1		
Bit	Symbol	Value	Description									
7	EEbusy	EEPROM Memory Busy Status Bit – (Read Only) (see EEPROM READ/WRITE)										
		0	The transfer is finished.									
		1	Indicates that the EEPROM is currently handling a read or write request and will ignore any further commands until the current one is finished. At power up a refresh is automatically generated. The time of this first refreshment is ~66 ms. After the refreshment is finished; EEbusy is cleared to 0 automatically.									
6	CLKF	Clock Output Interrupt Flag (see Programmable Clock Output)										
		0	No event detected. When cleared to 0 the frequency output will stop depending on CLKSY and FOUT settings.									
		1	If set to 0 beforehand, indicates the occurrence of an interrupt driven clock output on FOUT pin. The value 1 is retained until a 0 is written by the user.									
5	BSF	Backup Switch Flag (see AUTOMATIC BACKUP Switchover Function)										
		0	No backup switchover detected. At power up (POR) this flag is automatically cleared to 0. When the backup switchover function is disabled (PM field = 00) BSF is always logic 0.									
		1	If set to 0 beforehand, indicates that a switchover from main power V _{DD} to V _{BACKUP} has occurred. The value 1 can be cleared by writing a 0 to the bit if RTC module is in VDD Power state. Caution: The EVF flag is also set by an event of the Backup Switchover function when bits TSS and TSE are set to 1.									
4	UF	Periodic Time Update Flag (see Periodic Time Update Interrupt Function)										
		0	No event detected.									
		1	If set to 0 beforehand, indicates the occurrence of a Periodic Time Update Interrupt event. The value 1 is retained until a 0 is written by the user.									
3	TF	Periodic Countdown Timer Flag (see Periodic Countdown Timer Interrupt Function)										
		0	No event detected.									
		1	If set to 0 beforehand, indicates the occurrence of a Periodic Countdown Timer Interrupt event. The value 1 is retained until a 0 is written by the user.									
2	AF	Alarm Flag (see Alarm Interrupt Function)										
		0	No event detected.									
		1	If set to 0 beforehand, indicates the occurrence of an Alarm Interrupt event. The value 1 is retained until a 0 is written by the user.									
1	EVF	Event Flag (see External Event Function)										
		X	At POR, the default value depends on the voltage on the EVI pin and has to be cleared by writing a 0 to the bit. At POR EHL = 0, the low level is regarded as an External Event Interrupt. At POR, EVF = 0, no LOW level was detected on EVI pin. At POR, EVF = 1, LOW level was detected on EVI pin.									
		0	No event detected.									
0	PORF	Power On Reset Flag										
		0	No voltage drop detected.									
		1	If set to 0 beforehand, indicates a voltage drop below V _{POR} . The data in the device are no longer valid and all registers must be initialized. The value 1 is retained until a 0 is written by the user. At startup (POR) the value is set to 1, the user has to write 0 to the flag to use it.									

Table 21 Status (0x0Eh).

0Fh – Control 1. This register is used to specify the target for the Alarm Interrupt function and the Periodic Time Update Interrupt function and to select or set operations for the Periodic Countdown Timer. Read: Always readable. Write: Can be write-protected by password. Always readable. Write: Can be write-protected by password.

Address	Function	Conv.	Bit 7	Bit 6	Bit 5	Bit 4	Bit 3	Bit 2	Bit 1	Bit 0
0Fh	Control 1	R/WP	TRPT	-	WADA	USEL	EERD	TE	TD	
	Reset		0	0	0	0	0	0	0	0

Bit	Symbol	Value	Description
7	TRPT		Timer Repeat bit. Specifies either Single or Repeat Mode for the Periodic Countdown Timer Interruption function (see Periodic Countdown Timer Interrupt Function)
		0	Single Mode is selected. When the Countdown Timer is enabled (TE = 1) it will halt when it reaches zero and TE is automatically cleared. – Default value
		1	Repeat Mode is selected. When the Countdown Timer is enabled (TE = 1) it reloads the value from the Timer Value registers upon reaching 0, and continues counting.
6	-	0	Bit not implemented. Will return a 0 when read.
5	WADA		Weekday Alarm / Date Alarm selection bit. This bit is used to specify either the Weekday or Date as the source for the Alarm Interrupt function (see Alarm Interrupt Function).
		0	Weekday is the source for the Alarm Interrupt function. – Default value
		1	Date is the source for the Alarm Interrupt function.
4	USEL		Update Interrupt Select bit. Specifies either Second or Minute update for the Periodic Time Update Interrupt function. When 1 is written to the RESET bit the interrupt function is retarded (see Periodic Time Update Interrupt Function).
		0	Second update (Auto reset time $t_{RTN2} = 500$ ms). – Default value
		1	Minute update (Auto reset time $t_{RTN2} = 7.813$ ms).
3	EERD		EEPROM Memory Refresh Disable bit. When 1, disables the automatic refresh of the Configuration Registers from the non-volatile EEPROM Memory (see Refresh (ALL CONFIGURATION EEPROM → RAM)).
		0	Refresh is active. All data in the Configuration Registers are refreshed by the data stored in the EEPROM each 24 hours, at date increment (1 second before midnight). Refresh is only active when RTC is not in VBACKUP mode. At power up a refresh is automatically generated. The time of the first refreshment is ~66 ms. – Default value
		1	Refresh is disabled.
2	TE		Periodic Countdown Timer Enable bit. This bit controls the start/stop setting for the Periodic Countdown Timer Interruption function (see Periodic Countdown Timer Interrupt Function).
		0	Stops the Periodic Countdown Timer Interrupt function. TE is also automatically cleared when Single Mode is selected (TRPT = 0) and when the Countdown Timer reaches zero. – Default value
		1	Starts the Periodic Countdown Timer Interrupt function (a countdown starts from the preset value set in Timer Value registers).
1:0	TD	00 to 11	Timer Clock Frequency selection. Sets the countdown source clock for the Periodic Countdown Timer Interrupt function. With this setting the Auto reset time t_{RTN1} is also defined. When the clock source has been set to Second update (1 Hz) or Minute update (1/60 Hz), the timing of both, countdown and interrupts, is coordinated with the clock update timing. When 1 is written to the RESET bit, the interrupt function is retarded. See Table 22 Control 1 (0x0Fh) (see also Periodic Countdown Timer Interrupt Function).

TD Value	Timer Clock Frequency	Countdown period	t_{RTN1}	RESET bit
00	4096 Hz – Default value	244.14 μ s	122 μ s	When 1 is written to the RESET bit, the interrupt function is retarded
01	64 Hz	15.625 ms	7.813 ms	
10	1 Hz	1 s		
11	1/60 Hz	60 s		

Table 22 Control 1 (0x0Fh)

10h – Control 2. This register is used to control the interrupt event output for the nINT pin, the stop/start status of clock and calendar operations, the interrupt controlled clock output on FOUT pin, the hour mode and the time stamp enable. Read: Always readable. Write: Can be write-protected by password. Read: Always readable. Write: Can be write-protected by password.

Address	Function	Conv.	Bit 7	Bit 6	Bit 5	Bit 4	Bit 3	Bit 2	Bit 1	Bit 0
10h	Control 2	R/WP	TSE	CLKIE	UIE	TIE	AIE	EIE	12_24	RESET
	Reset		0	0	0	0	0	0	0	0
Bit	Symbol	Value	Description							
7	TSE	Time Stamp Enable bit (see TIME STAMP Function)								
		0	Disables the time stamp function. – Default value							
		1	Enables the Time stamp function.							
6	CLKIE	Interrupt Controlled Clock Output Enable bit. When enabled, it is possible to wake-up an external system by outputting a frequency. (see Programmable Clock Output)								
		0	Disabled – Default value							
		1	When set to 1, the clock output on FOUT pin is automatically enabled when an interrupt occurs, based on the Clock Interrupt Mask Register (12h) and according to clock setting defined by the FD field. This function is disabled in VBACKUP Power state.							
5	UIE	Periodic Time Update Interrupt Enable bit (see Periodic Time Update Interrupt Function)								
		0	No interrupt signal is generated on nINT pin when a Periodic Time Update event occurs or the signal is cancelled on nINT pin. – Default value							
		1	An interrupt signal is generated on nINT pin when a Periodic Time Update event occurs. The low-level output signal is automatically cleared after $t_{RTN2} = 500$ ms (Second update) or $t_{RTN2} = 7.813$ ms (Minute update).							
4	TIE	Periodic Countdown Timer Interrupt Enable bit(see Periodic Time Update Interrupt Function)								
		0	No interrupt signal is generated on nINT pin when a Periodic Countdown Timer event occurs or the signal is cancelled on nINT pin. – Default value							
		1	An interrupt signal is generated on nINT pin when a Periodic Countdown Timer event occurs. The low-level output signal is automatically cleared after $t_{RTN1} = 122$ μ s (TD = 00) or $t_{RTN1} = 7.813$ ms (TD = 01, 10, 11).							
3	AIE	Alarm Interrupt Enable bit (see Alarm Interrupt Function)								
		0	No interrupt signal is generated on nINT pin when an Alarm event occurs or the signal is cancelled on nINT pin. – Default value							
		1	An interrupt signal is generated on nINT pin when an Alarm event occurs. This setting is retained until the AF flag is cleared to 0 (no automatic cancellation).							
2	EIE	Event Interrupt Enable bit(see External Event Function and Interrupt Scheme)								
		0	No interrupt signal is generated on nINT pin when an External Event on EVI pin occurs, or when an Automatic Backup Switchover occurs when TSS and TSE are set to 1, or the signal on nINT pin is cleared. – Default value							
		1	An interrupt signal is generated on nINT pin when an External Event on EVI pin occurs, or when an Automatic Backup Switchover occurs when TSS and TSE are set to 1. The signal on nINT pin is retained until the EVF flag is cleared to 0 (no automatic cancellation).							
1	12_24	12 or 24 hour mode (see Clock Registers and Alarm Registers)								
		0	24 hour mode is selected (0 to 23). – Default value							
		1	12 hour mode is selected (1 to 12).							
0	RESET	Reset bit. This bit is used for a software-based time adjustment (synchronizing)(see RESET bit Function).								
		1	When 1 is written to the RESET bit, the clock prescaler from 4096 Hz to 1 Hz is reset. An eventual present memorized 1 Hz update is also reset. The RESET bit is then automatically cleared. Because the upper two stages of the prescaler are not reset (16.384 kHz and 8192 Hz) and the I ² C interface is asynchronous, the first 1 Hz period after synchronization will be 0 to 244 μ s shorter than 1 second. Resetting the prescaler will have an influence on the length of the current clock period on all subsequent peripherals (clock and calendar, FOUT, timer clock, update timer clock, UNIX clock, EVI input filter).							

Table 23 Control 2 (0x10h).

11h – GP Bits. This register holds the bits for general purpose use (7 bits). Read: Always readable. Write: Can be write-protected by password.

Address	Function	Conv.	Bit 7	Bit 6	Bit 5	Bit 4	Bit 3	Bit 2	Bit 1	Bit 0
11h	GP Bits	R/WP	-	GP6	GP5	GP4	GP3	GP2	GP1	GP0
	Reset		0	0	0	0	0	0	0	0
Bit	Symbol	Value	Description							
7	-	0	Bit not implemented. Will return a 0 when read.							
6:0	GPx	0 or 1	Register bits for general purpose use (7 bits).							

Table 24 GP bits (0x11h).

12h – Clock Interrupt Mask. This register is used to select a predefined interrupt for automatic clock output. Setting a bit to 1 selects the corresponding interrupt. Multiple interrupts can be selected. After power on, no interrupt is selected (see [Clock Output Scheme](#)). Read: Always readable. Write: Can be write-protected by password.

Address	Function	Conv.	Bit 7	Bit 6	Bit 5	Bit 4	Bit 3	Bit 2	Bit 1	Bit 0
12h	Clock Interrupt Mask	R/WP	-	-	-	-	CEIE	CAIE	CTIE	CUIE
	Reset		0	0	0	0	0	0	0	0
Bit	Symbol	Value	Description							
7:4		0	Bit not implemented. Will return a 0 when read.							
3	CEIE	Clock output when Event Interrupt bit. The source for the Event Interrupt can be the External Event from EVI pin or the Automatic Backup Switchover (see Interrupt Scheme).								
		0	Disabled – Default value							
		1	Enabled. Internal signal EI is selected.							
2	CAIE	Clock output when Alarm Interrupt bit.								
		0	Disabled – Default value							
		1	Enabled. Internal signal AI is selected.							
1	CTIE	Clock output when Periodic Countdown Timer Interrupt bit.								
		0	Disabled – Default value							
		1	Enabled: Internal signal TI is selected.							
0	CUIE	Clock output when Periodic Time Update Interrupt bit.								
		0	Disabled – Default value							
		1	Enabled: Internal signal TI is selected.							

Table 25 Clock Interrupt Mask (0x12h).

6.6. EVENT CONTROL REGISTER

13h – Event Control. This register controls the event detection on the EVI pin. Depending of the EHL bit a high or a low signal can be detected. Moreover a digital glitch filtering can be applied to the EVI signal by selecting a sampling period in the ET field. Furthermore this register holds control functions for the Time Stamp data. And the switching over to VBACKUP Power state can be selected as source for an event. Read: Always readable. Write: Can be write-protected by password.

Address	Function	Conv.	Bit 7	Bit 6	Bit 5	Bit 4	Bit 3	Bit 2	Bit 1	Bit 0	
13h	Event Control	R/WP	○	EHL	ET		○	TSR	TSOW	TSS	
	Reset		0	0	0	0	0	0	0	0	
Bit	Symbol	Value	Description								
7	○	0	Read only. Always 0.								
6	EHL	Event High/Low detection Select (see External Event Function)									
		0	The low level (negative edge) is regarded as the External Event on pin EVI. – Default value								
		1	The high level (positive edge) is regarded as the External Event on pin EVI.								
5:4	ET	Event Filtering Time set. Applies a digital filtering to the EVI pin by sampling the EVI signal. Edge and stable steady state are detected when ET = 01, 10 or 11 (see Use of the External Event Function)									
		00	No filtering. Edge detection (minimal pulse time is 30.5 μs). – Default value								
		01	3.9 ms sampling period (256 Hz).								
		10	15.6 ms sampling period (64 Hz).								
		11	125 ms sampling period (8 Hz).								
3	○	0									
2	TSR	Time Stamp Reset bit (see TIME STAMP Function)									
		0	Disables the Time Stamp Reset. – Default value								
		1	When this bit is set to 1, all seven time stamp registers (Count TS to Year TS) are cleared to 00h. The TSR bit is automatically cleared to 0 after performing the reset.								
1	TSOW	Time Stamp Overwrite bit. Controls the overwrite function of the TS registers. Exception: The counter Count TS is always working, independent of the settings of the overwrite bit TSOW. (see TIME STAMP Function)									
		0	The time stamp of the first occurred event is recorded and remains in TS registers. To initialize or reinitialize the first event detection function, the EVF has to be cleared. – Default value								
		1	The time stamp of the last occurred event is recorded and TS registers are overwritten. The EVF flag does not need to be cleared.								
0	TSS	Time Stamp Source Selection bit (see TIME STAMP Function)									
		0	A time stamp is generated (if TSE = 1) when an External Event on EVI pin occurs – Default value								
		1	A time stamp is generated (if TSE = 1) when the circuit goes to VBACKUP Power state.								

Table 26 Event Control (0x13h).

6.7. TIME STAMP REGISTERS

14h – Count TS. This register contains the number of occurrences of the corresponding event in standard binary format. The values range from 0 to 255. It is read only. Writing to this register has no effect.

Address	Function	Conv.	Bit 7	Bit 6	Bit 5	Bit 4	Bit 3	Bit 2	Bit 1	Bit 0
14h	Count TS	R	128	64	32	16	8	4	2	1
	Reset		0	0	0	0	0	0	0	0
Bit	Symbol	Value	Description							
7:0	Count TS	0 to 255	Number of occurrences of the corresponding event, coded in binary. In case of an overflow the counter starts again with 00h When bit TSE = 0, the counter stops counting events. When bit TSE = 1, the counter is increased when event occurs. The counter Count TS is always working, independent of the settings of the overwrite bit TSOW. The Count TS register is cleared to 00h when a 1 is written to the reset bit TSR (see TIME STAMP Function)							

Table 27 Count TS (0x14h).

15h – Seconds TS. This register holds a recorded Time Stamp of the Seconds register, in two binary coded decimal (BCD) digits. The values are from 00 to 59. It is read only. Writing to this register has no effect.

Address	Function	Conv.	Bit 7	Bit 6	Bit 5	Bit 4	Bit 3	Bit 2	Bit 1	Bit 0
15h	Seconds TS	R	0	40	20	10	8	4	2	1
	Reset		0	0	0	0	0	0	0	0
Bit	Symbol	Value	Description							
7	0	0	Read only. Always 0.							
6:0	Seconds TS	00 to 59	Holds a recorded Time Stamp of the Seconds register, coded in BCD format. When enabled (bit TSE = 1), Depending on the setting of the TSOW bit it contains the time stamp of the first or last occurred event. The Seconds TS register is cleared to 00h when a 1 is written to the reset bit TSR.							

Table 28 Seconds TS (0x15h).

16h – Minutes TS. This register holds a recorded Time Stamp of the Minutes register, in two binary coded decimal (BCD) digits. The values are from 00 to 59. It is read only. Writing to this register has no effect.

Address	Function	Conv.	Bit 7	Bit 6	Bit 5	Bit 4	Bit 3	Bit 2	Bit 1	Bit 0
16h	Minutes TS	R	0	40	20	10	8	4	2	1
	Reset		0	0	0	0	0	0	0	0
Bit	Symbol	Value	Description							
7	0	0	Read only. Always 0.							
6:0	Minutes TS	00 to 59	Holds a recorded Time Stamp of the Minutes register, coded in BCD format. When enabled (bit TSE = 1), Depending on the setting of the TSOW bit it contains the time stamp of the first or last occurred event. The Minutes TS register is cleared to 00h when a 1 is written to the reset bit TSR.							

Table 29 Minutes TS (0x16h).

17h – Hours TS. This register holds a recorded Time Stamp of the Hours register, in two binary coded decimal (BCD) digits. If the 12_24 bit is cleared (default) (see **Configuration Registers**, 10h – Control 2) the values will be from 0 to 23. If the 12_24 bit is set, the hour values will range from 1 to 12 and the AMPM bit will be 0 for AM hours and 1 for PM hours. It is read only. Writing to this register has no effect.

Address	Function	Conv.	Bit 7	Bit 6	Bit 5	Bit 4	Bit 3	Bit 2	Bit 1	Bit 0
17h	Hours TS (24 hour mode) – default value	R	○	○	20	10	8	4	2	1
	Hours TS (12 hour mode)				AMPM	10	8	4	2	1
	Reset		0	0	0	0	0	0	0	0

Hours TS (24 hour mode) – default value

Bit	Symbol	Value	Description
7:6	○	0	Read only. Always 0.
5:0	Hours TS (24 hour mode) – default value	0 to 23	Holds a recorded Time Stamp of the Hours register, coded in BCD format. When enabled (bit TSE = 1), Depending on the setting of the TSOW bit it contains the time stamp of the first or last occurred event. The Hours TS register is cleared to 00h when a 1 is written to the reset bit TSR.

Hours TS (12 hour mode)

Bit	Symbol	Value	Description
7:6	○	0	Read only. Always 0.
5	AMPM	0	AM hours, from the recorded Time Stamp of the Hours register.
		1	PM hours, from the recorded Time Stamp of the Hours register.
4:0	Hours TS (12 hour mode)	1 to 12	Holds a recorded Time Stamp of the Hours register, coded in BCD format. When enabled (bit TSE = 1), Depending on the setting of the TSOW bit it contains the time stamp of the first or last occurred event. The Hours TS register is cleared to 00h when a 1 is written to the reset bit TSR.

Table 30 Hours TS (0x17h).

18h – Date TS. This register holds a recorded Time Stamp of the Date register, in two binary coded decimal (BCD) digits. The values will range from 01 to 31. It is read only. Writing to this register has no effect.

Address	Function	Conv.	Bit 7	Bit 6	Bit 5	Bit 4	Bit 3	Bit 2	Bit 1	Bit 0
18h	Date TS	R	○	○	20	10	8	4	2	1
	Reset		0	0	0	0	0	0	0	0

Bit	Symbol	Value	Description
7:6	○	0	Read only. Always 0.
5:0	Date TS	01 to 31	Holds a recorded Time Stamp of the Date register, coded in BCD format. When enabled (bit TSE = 1), Depending on the setting of the TSOW bit it contains the time stamp of the first or last occurred event. The Date TS register is cleared to 00h when a 1 is written to the reset bit TSR. After POR or when reset with bit TSR and when a Time Stamp is recorded, the value 00 will be automatically replaced by a valid value (01 to 31).

Table 31 Date TS (0x18h).

19h – Month TS. This register holds a recorded Time Stamp of the Month register, in two binary coded decimal (BCD) digits. The values will range from 01 to 12. It is read only. Writing to this register has no effect.

Address	Function	Conv.	Bit 7	Bit 6	Bit 5	Bit 4	Bit 3	Bit 2	Bit 1	Bit 0
19h	Month TS	R	o	o	o	10	8	4	2	1
	Reset		0	0	0	0	0	0	0	0
Bit	Symbol	Value	Description							
7:5	o	0	Read only. Always 0.							
4:0	Month TS	01 to 12	Holds a recorded Time Stamp of the Month register, coded in BCD format. When enabled (bit TSE = 1), Depending on the setting of the TSOW bit it contains the time stamp of the first or last occurred event. The Month TS register is cleared to 00h when a 1 is written to the reset bit TSR. After POR or when reset with bit TSR and when a Time Stamp is recorded, the value 00 will be automatically replaced by a valid value (01 to 12).							

Table 32 Month TS (0x19h).

1Ah – Year TS. This register holds a recorded Time Stamp of the Year register, in two binary coded decimal (BCD) digits. Values will range from 00 to 99. It is read only. Writing to this register has no effect.

Address	Function	Conv.	Bit 7	Bit 6	Bit 5	Bit 4	Bit 3	Bit 2	Bit 1	Bit 0
1Ah	Year TS	R	80	40	20	10	8	4	2	1
	Reset		0	0	0	0	0	0	0	0
Bit	Symbol	Value	Description							
7:0	Year TS	00 to 99	Holds a recorded Time Stamp of the Year register, coded in BCD format. When enabled (bit TSE = 1), Depending on the setting of the TSOW bit it contains the time stamp of the first or last occurred event. The Year TS register is cleared to 00h when a 1 is written to the reset bit TSR.							

Table 33 Year TS (0x1Ah).

6.8. UNIX TIME REGISTERS

The UNIX Time counter is a 32-bit counter with the value in binary format. The counter will roll-over to 00000000h when reaching FFFFFFFFh. The 4 counter registers are fully readable and writable. The counter source clock is the digitally tuned 1 Hz clock frequency. The UNIX Time counter increment is inhibited during I²C write access to the 4 UNIX Time registers to allow coherent data values (see **Setting and Reading the Time**). Read: Always readable. Write: Can be write-protected by password.

1Bh – UNIX Time 0. Bit 0 to 7 from 32-bit UNIX Time counter.

Address	Function	Conv.	Bit 7	Bit 6	Bit 5	Bit 4	Bit 3	Bit 2	Bit 1	Bit 0
1Bh	UNIX Time 0	R/WP	UNIX 0 [7:0]							
	Reset		0	0		Reset	0	0		Reset
Bit	Symbol	Value	Description							
7:0	UNIX 0 [7:0]	00h to FFh	Bit 0 to 7 from 32-bit UNIX counter.							

Table 34 UNIX Time 0 (0x1Bh).

1Ch – UNIX Time 1. Bit 8 to 15 from 32-bit UNIX Time counter.

Address	Function	Conv.	Bit 7	Bit 6	Bit 5	Bit 4	Bit 3	Bit 2	Bit 1	Bit 0
1Ch	UNIX Time 1	R/WP	UNIX 1 [15:8]							
	Reset		0	0		Reset	0	0		Reset
Bit	Symbol	Value	Description							
7:0	UNIX 1 [15:8]	00h to FFh	Bit 8 to 15 from 32-bit UNIX counter.							

Table 35 UNIX Time 1 (0x1Ch).

1Dh – UNIX Time 2. Bit 16 to 23 from 32-bit UNIX Time counter.

Address	Function	Conv.	Bit 7	Bit 6	Bit 5	Bit 4	Bit 3	Bit 2	Bit 1	Bit 0
1Dh	UNIX Time 2	R/WP	UNIX 2 [23:16]							
	Reset		0	0		Reset	0	0		Reset
Bit	Symbol	Value	Description							
7:0	UNIX 2 [23:16]	00h to FFh	Bit 16 to 23 from 32-bit UNIX counter.							

Table 36 UNIX Time 2 (0x1Dh).

1Eh – UNIX Time 3. Bit 24 to 31 from 32-bit UNIX Time counter.

Address	Function	Conv.	Bit 7	Bit 6	Bit 5	Bit 4	Bit 3	Bit 2	Bit 1	Bit 0
1Eh	UNIX Time 3	R/WP	UNIX 3 [31:24]							
	Reset		0	0		Reset	0	0		Reset
Bit	Symbol	Value	Description							
7:0	UNIX 3 [31:24]	00h to FFh	Bit 24 to 31 from 32-bit UNIX counter.							

Table 37 UNIX Time 3 (0x1Eh).

6.9. RAM REGISTERS

Two free RAM bytes, which can be used for any purpose, for example, status bytes of the system.

1Fh – User RAM 1. This register holds the bits for general purpose use. Read: Always readable. Write: Can be write-protected by password.

Address	Function	Conv.	Bit 7	Bit 6	Bit 5	Bit 4	Bit 3	Bit 2	Bit 1	Bit 0
1Fh	User RAM 1	R/WP	RAM 1							
	Reset		0	0	0	0	0	0	0	0
Bit	Symbol	Value	Description							
7:0	RAM 1	00h to FFh	RAM 1 data							

Table 38 User RAM 1 (0x1Fh)

20h – User RAM 2. This register holds the bits for general purpose use. Read: Always readable. Write: Can be write-protected by password.

Address	Function	Conv.	Bit 7	Bit 6	Bit 5	Bit 4	Bit 3	Bit 2	Bit 1	Bit 0
20h	User RAM 2	R/WP	RAM 2							
	Reset		0	0	0	0	0	0	0	0
Bit	Symbol	Value	Description							
7:0	RAM 2	00h to FFh	RAM 2 data							

Table 39 User RAM 2 (0x20h)

6.10. PASSWORD REGISTERS

After a Power up and the first refreshment of ~66 ms, the PW 0 to PW 3 registers are reset to 00h.

When enabled by writing 255 into the EEPROM Password Enable register EEPWE (EEPROM 30h), the Password registers are used to be written with the 32-Bit Password necessary to be able to write into all writable registers (for time and configuration registers). This 32-Bit Password is compared to the 32 bits stored in the EEPROM Password registers EEPW 0 to EEPW 3 (EEPROM 31h to 34h) (see [EEPROM Password Registers](#)).

21h – Password 0. Bit 0 to 7 from 32-bit Password. Write only. Returns 0 when read.

Address	Function	Conv.	Bit 7	Bit 6	Bit 5	Bit 4	Bit 3	Bit 2	Bit 1	Bit 0
21h	Password 0	W	PW 0 [7:0]							
	Reset		0	0	0	0	0	0	0	0
Bit	Symbol	Value	Description							
7:0	PW 0 [7:0]	00h to FFh	Bit 0 to 7 from 32-bit Password							

Table 40 Password 0 (0x21h)

22h – Password 1. Bit 8 to 15 from 32-bit Password. Write only. Returns 0 when read.

Address	Function	Conv.	Bit 7	Bit 6	Bit 5	Bit 4	Bit 3	Bit 2	Bit 1	Bit 0
22h	Password 1	W	PW 1 [15:8]							
	Reset		0	0	0	0	0	0	0	0
Bit	Symbol	Value	Description							
7:0	PW 1 [15:8]	00h to FFh	Bit 8 to 15 from 32-bit Password							

Table 41 Password 1 (0x22h)

23h – Password 2. Bit 16 to 23 from 32-bit Password. Write only. Returns 0 when read.

Address	Function	Conv.	Bit 7	Bit 6	Bit 5	Bit 4	Bit 3	Bit 2	Bit 1	Bit 0
23h	Password 2	W	PW 2 [23:16]							
	Reset		0	0	0	0	0	0	0	0
Bit	Symbol	Value	Description							
7:0	PW 2 [23:16]	00h to FFh	Bit 16 to 23 from 32-bit Password							

Table 42 Password 2 (0x23h)

24h – Password 3. Bit 24 to 31 from 32-bit Password. Write only. Returns 0 when read.

Address	Function	Conv.	Bit 7	Bit 6	Bit 5	Bit 4	Bit 3	Bit 2	Bit 1	Bit 0
24h	Password 3	W	PW 3 [31:24]							
	Reset		0	0	0	0	0	0	0	0
Bit	Symbol	Value	Description							
7:0	PW 3 [31:24]	00h to FFh	Bit 24 to 31 from 32-bit Password							

Table 43 Password 3 (0x24h)

6.11. EEPROM MEMORY CONTROL REGISTERS

See also [EEPROM READ/WRITE](#).

25h –EEPROM Address. This register holds the Address used for read or write from/to a single EEPROM Memory byte. Read: Always readable. Write: Can be write-protected by password

Address	Function	Conv.	Bit 7	Bit 6	Bit 5	Bit 4	Bit 3	Bit 2	Bit 1	Bit 0
25h	EEPROM Address	R/WP	EEaddr							
	Reset		0	0	0	0	0	0	0	0
Bit	Symbol	Value	Description							
7:0	EEaddr	00h to FFh	Address for direct read or write one EEPROM Memory byte.							

Table 44 EEPROM Address (0x25h)

26h –EEPROM Data. This register holds the Data that are read from, or that are written to a single EEPROM Memory byte. Read: Always readable. Write: Can be write-protected by password.

Address	Function	Conv.	Bit 7	Bit 6	Bit 5	Bit 4	Bit 3	Bit 2	Bit 1	Bit 0
26h	EEPROM Data	R/WP	EEdata							
	Reset		X	X	X	X	X	X	X	X
Bit	Symbol	Value	Description							
7:0	EEdata	00h to FFh	Data from direct read or for direct write to one EEPROM Memory byte.							

Table 45 EEPROM Data (0x26h)

27h –EEPROM Commands. This register must be written with specific values, in order to read or write all (readable/writeable) configuration registers or to read or write from/to a single EEPROM Memory byte. Before using this commands, the automatic refresh function has to be disabled (EERD = 1) and the busy status bit EEbusy has to indicate, that the last transfer has been finished (EEbusy = 0). Before entering the command 11h, 12h, 21h or 22h, EEcmd has to be written with 00h. Write only. It can be write-protected by password.

Address	Function	Conv.	Bit 7	Bit 6	Bit 5	Bit 4	Bit 3	Bit 2	Bit 1	Bit 0
27h	EEPROM Commands	WP	EEcmd							
	Reset		0	0	0	0	0	0	0	0
Bit	Symbol	Value	Description							
7:0	EEcmd	Commands for EEPROM Memory (see EEPROM READ/WRITE)								
		00h	First command must be 00h. – Default value							
		11h	Write to all Configuration EEPROM registers (Update). When writing a value of 11h, data from all (readable/writeable) configuration RAM bytes (address 30h to 37h) are written (stored) into the corresponding EEPROM bytes.							
		12h	Read all Configuration EEPROM registers (Refresh). When writing a value of 12h, data from all Configuration EEPROM bytes are read and copied into the corresponding RAM bytes (address 30h to 37h).							
		21h	Write to one EEPROM byte (Configuration or User EEPROM). When writing a value of 21h, data from EEdata byte is written (stored) into the EEPROM byte with the address specified in EEaddr. (For Configuration EEPROM bytes (address 30h to 37h) and User EEPROM bytes (address 00h to 2Ah)).							
22h	Read one EEPROM byte (from Configuration or User EEPROM). When writing a value of 22h, data from the EEPROM byte with the address specified in EEaddr is read and copied into the EEdata byte. (For Configuration EEPROM bytes (address 30h to 37h) and User EEPROM bytes (address 00h to 2Ah)).									

Table 46 EEPROM Commands (0x27h)

6.12. ID REGISTER

28h – ID. This register holds the 4 bit Hardware Identification number (HID) and the 4 bit Version Identification number (VID).

The ID can be used to monitor a hardware modification and the version in the production line. It is read only. Writing to this register has no effect.

Address	Function	Conv.	Bit 7	Bit 6	Bit 5	Bit 4	Bit 3	Bit 2	Bit 1	Bit 0
28h	ID	R	HID				VID			
	Reset		Preconfigured Value				Preconfigured Value			
Bit	Symbol	Value	Description							
7:4	HID	0 to 15	Hardware Identification number.							
3:0	VID	0 to 15	Version Identification number.							

Table 47 ID Register (0x28h)

6.13. CONFIGURATION EEPROM WITH RAM MIRROR REGISTERS

All Configuration EEPROM at addresses 2Bh and 30h to 37h are memorized in the EEPROM and mirrored in the RAM.

6.13.1. EEPROM RESERVED

2Bh – EEPROM Reserved. Read: Always readable. Write: Can be write-protected by password. It must not be overwritten.

Address	Function	Conv.	Bit 7	Bit 6	Bit 5	Bit 4	Bit 3	Bit 2	Bit 1	Bit 0
2Bh	EEPROM RESERVED	R/WP	RESERVED (Must not be overwritten)							
	Default value on delivery		Preconfigured Value							
Bit	Symbol	Value	Description							
7:0	RESERVED		Preconfigured Value – It must not be overwritten.							

Table 48 EEPROM Reserved (0x2Bh)

6.13.2. EEPROM PASSWORD ENABLE REGISTER

After a Power up and the first refreshment of ~66 ms, the Password Enable value EEPWE is copied from the EEPROM. The default value preset on delivery is 00h.

30h – EEPROM Password Enable. Read: Always readable. Write: Can be write-protected by password.

Address	Function	Conv.	Bit 7	Bit 6	Bit 5	Bit 4	Bit 3	Bit 2	Bit 1	Bit 0
30h	EEPROM Password Enable	R/WP	EEPWE							
	Default value on delivery		0	0	0	0	0	0	0	0
Bit	Symbol	Value	Description							
7:0	EEPWE		EEPROM Password Enable							
		0 to 254	Password function disabled. When writing a value not equal 255, the password function is disabled. – 00h is default value preset on delivery							
		255	Password function enabled. When writing a value of 255, the Password registers (21h to 24h) can be used to enter the 32-bit Password.							

Table 49 EEPROM Password Enable (0x30h)

6.14. EEPROM PASSWORD REGISTERS

After a Power up and the first refreshment of ~66 ms, the EEPROM Password values EEPW 0 to EEPW 3 are copied from the EEPROM. The default values preset on delivery are 00h.

31h – EEPROM Password 0. Bit 0 to 7 from 32-bit EEPROM Password. Write only. It can be write-protected by password.

Address	Function	Conv.	Bit 7	Bit 6	Bit 5	Bit 4	Bit 3	Bit 2	Bit 1	Bit 0
31h	EEPROM Password 0	WP	EEPW 0 [7:0]							
	Default value on delivery		0	0	0	0	0	0	0	0
Bit Symbol Value Description										
7:0	EEPW 0 [7:0]		00h to FFh	Bit 0 to 7 from 32-bit EEPROM Password						

Table 50 EEPROM Password 0 (0x31h)

32h – EEPROM Password 1. Bit 8 to 15 from 32-bit EEPROM Password. Write only. It can be write-protected by password.

Address	Function	Conv.	Bit 7	Bit 6	Bit 5	Bit 4	Bit 3	Bit 2	Bit 1	Bit 0
32h	EEPROM Password 1	WP	EEPW 1 [15:8]							
	Default value on delivery		0	0	0	0	0	0	0	0
Bit Symbol Value Description										
7:0	EEPW 1 [15:8]		00h to FFh	Bit 8 to 15 from 32-bit EEPROM Password						

Table 51 EEPROM Password 1 (0x32h)

33h – EEPROM Password 2. Bit 16 to 23 from 32-bit EEPROM Password. Write only. It can be write-protected by password.

Address	Function	Conv.	Bit 7	Bit 6	Bit 5	Bit 4	Bit 3	Bit 2	Bit 1	Bit 0
33h	EEPROM Password 2	WP	EEPW 2 [23:16]							
	Default value on delivery		0	0	0	0	0	0	0	0
Bit Symbol Value Description										
7:0	EEPW 2 [23:16]		00h to FFh	Bit 16 to 23 from 32-bit EEPROM Password						

Table 52 EEPROM Password 2 (0x33h)

34h – EEPROM Password 3. Bit 24 to 31 from 32-bit EEPROM Password. Write only. It can be write-protected by password.

Address	Function	Conv.	Bit 7	Bit 6	Bit 5	Bit 4	Bit 3	Bit 2	Bit 1	Bit 0
34h	EEPROM Password 3	WP	EEPW 3 [31:24]							
	Default value on delivery		0	0	0	0	0	0	0	0
Bit Symbol Value Description										
7:0	EEPW 3 [31:24]		00h to FFh	Bit 24 to 31 from 32-bit EEPROM Password						

Table 53 EEPROM Password 3 (0x34h)

6.15. EEPROM FOUT REGISTER

35h – EEPROM FOUT. A programmable square wave output is available at FOUT pin. Operation is enabled by the CLKOE bit (see **Programmable Clock**). Read: Always readable. Write: Can be write-protected by password.

Address	Function	Conv.	Bit 7	Bit 6	Bit 5	Bit 4	Bit 3	Bit 2	Bit 1	Bit 0
35h	EEPROM FOUT	R/WP	CLKOE	CLKSY	-	-	PORIE	FD		
	Default value on delivery		1	1	0	0	0	0	0	0
Bit	Symbol	Value	Description							
7	CLKOE	FOUT Enable bit (see Programmable Clock Output)								
		0	The FOUT pin is LOW.							
		1	The clock output signal on FOUT pin is enabled. – Default value on delivery							
6	CLKSY	FOUT Synchronized enable/disable (see Synchronized Enable/Disable)								
		0	Disabled							
		1	Enables the Synchronized enable/disable (by CLKOE) of the FOUT frequency. – Default value on delivery							
5:4	-	0	Bit not implemented. Will return a 0 when read.							
3	PORIE	Power On Reset Interrupt Enable bit(see POWER ON RESET Interrupt Function)								
		0	No interrupt signal is generated on nINT pin when a Power On Reset occurs or the signal is cancelled on nINT pin. – Default value on delivery							
		1	An interrupt signal is generated on nINT pin when a Power On Reset occurs. This setting is retained until the PORF flag is cleared to 0 (no automatic cancellation).							
2:0	FD	000 to 111	FOUT Frequency Selection (see FOUT Frequency Selection)							
FD	FOUT Frequency Selection		Effect when 1 is written to the RESET bit							
000	32.768 kHz – Default value on delivery		No effect							
001	8192 Hz (1)		No effect							
010	1024 Hz (1)		FOUT goes LOW							
011	64 Hz (1)		FOUT goes LOW							
100	32 Hz (1)		FOUT goes LOW							
101	1 Hz (1)		FOUT goes LOW							
110	Predefined periodic countdown timer interrupt (1) (2)		FOUT goes LOW							
111	FOUT = LOW		No effect							
(1) 8192 Hz to 1 Hz clock pulses and the timer interrupt pulses can be affected by compensation pulses (Frequency OFFSET Correction). (2) CLKSY bit has no effect.										

Table 54 EEPROM FOUT Register (0x35h).

6.16. EEPROM OFFSET REGISTER

The registers EEPROM Offset and EEPROM Backup hold the EEOffset value to digitally compensate the initial frequency deviation of the 32.768 kHz oscillator or for aging adjustment (see [Frequency OFFSET Correction](#)).

Caution: Bit EEOffset [0] is in the

36h – EEPROM Offset. This register holds the upper 8 bits of the EEOffset value. Read: Always readable. Write: Can be write-protected by password.

Address	Function	Conv.	Bit 7	Bit 6	Bit 5	Bit 4	Bit 3	Bit 2	Bit 1	Bit 0
36h	EEPROM Offset	R/WP	EEOffset [8:1]							
	Default value on delivery		0	0	0	0	0	0	0	0
Bit	Symbol	Value	Description							
7:0	EEOffset [8:1]	00h to FFh	Bits 8 to 1 of the EEOffset [8:0] value. EEOffset defines correction pulses in steps. Each pulse introduces a deviation of 0.9537 ppm, the maximum range is from +243.2 ppm to -244.1 ppm. The value of 0.9537 ppm is based on a nominal 32.768 kHz clock (see Frequency OFFSET Correction)							

Table 55 EEPROM Offset (0x36h)

6.17. EEPROM BACKUP REGISTER

37h – EEPROM Backup. This register is used to control the switchover function and the trickle charger and it holds bit 0 (LSB) of the EEOffset value. Read: Always readable. Write: Can be write-protected by password.

Address	Function	Conv.	Bit 7	Bit 6	Bit 5	Bit 4	Bit 3	Bit 2	Bit 1	Bit 0
37h	EEPROM Backup	R/WP	EEOffset [0]	BSIE	TCE	FEDE	BSM		TCR	
	Default value on delivery		0	0	0	1	0	0	0	0
Bit	Symbol	Value	Description							
7	EEOffset [0]	0 to 1	Bit 0 of the EEOffset [8:0] value. EEOffset defines correction pulses in steps. Each pulse introduces a deviation of 0.9537 ppm, the maximum range is from +243.2 ppm to -244.1 ppm. The value of 0.9537 ppm is based on a nominal 32.768 kHz clock (see Frequency OFFSET Correction)							
6	BSIE	Backup Switchover Interrupt Enable bit (see AUTOMATIC BACKUP Switchover Function and Automatic BACKUP Switchover Interrupt Function)								
		0	No interrupt signal is generated on nINT pin when an Automatic Backup Switchover occurs or the signal is cancelled on nINT pin.– Default value on delivery							
		1	An interrupt signal is generated on nINT pin when an Automatic Backup Switchover occurs. This setting is retained until the BSF flag is cleared to 0 (no automatic cancellation).							
5	TCE	Trickle Charger Enable bit (see Trickle Charger)								
		0	Disabled – Default value on delivery							
		1	Enabled							
4	FEDE	Fast Edge Detection Enable bit (see AUTOMATIC BACKUP Switchover Function and Automatic BACKUP Switchover Interrupt Function)								
		0	Disabled.							
		1	FEDE should always be set to 1. When the FEDE bit is 1, the Fast Edge Detection for the Automatic Backup Switchover function is enabled. A voltage with a rising or falling edge with a slew rate typically bigger than 7 V/ms can be recorded correctly on V _{DD} power supply pin and the Automatic Backup Switchover function is adapted to this specific situation. – Default value on delivery							
3:2	BSM	Backup Switchover Mode(see AUTOMATIC BACKUP Switchover Function and Automatic BACKUP Switchover Interrupt Function) To read/write to/from the EEPROM, the user has to disable the Backup Switchover function by setting the BSM field to 00 or 10 (see routine in EEPROM Read/Write Conditions)								
		00	Switchover Disabled. The automatic backup switchover function is disabled. Used when only one power supply is available (V _{DD}). V _{BACKUP} pin should be connected to ground. – Default value on delivery							
		01	Enables the Direct Switching Mode (DSM). Switchover when V _{DD} < V _{BACKUP} .							
		10	Standby Mode. When V _{DD} < V _{BACKUP} the device enters the standby mode and does not draw any current from the backup source before it is powered up again from main supply V _{DD} .							
		11	Enables the Level Switching Mode (LSM). Switchover when V _{DD} < V _{BACKUP} AND V _{DD} < V _{DDSW} (AND V _{BACKUP} > V _{DDSW}).							
1:0	TCR	Trickle Charger Series Resistance (see Trickle Charger)								
		00	TCR = 1 kΩ – Default value on delivery							
		01	TCR = 3 kΩ							
		10	TCR = 6 kΩ							
		11	TCR = 11 kΩ							

Table 56 EEPROM Backup Register (0x37h).

EEOffset [8:0]	EEOffset correction value in decimal	Correction pulses in steps	FOUT frequency correction in ppm(*)
011111111	255	255	243.187
011111110	254	254	242.233
:	:	:	:
000000001	1	1	0.954
000000000 (default)	0	0	0.000
111111111	511	-1	-0.954
111111110	510	-2	-1.907
:	:	:	:
100000001	257	-255	-243.187
100000000	256	-256	-244.141

(*)Each correction pulse corresponds to $1 / (32768 \times 32) = 0.9537$ ppm. The frequency deviation measured at FOUT pin can be compensated by computing the correction value EEOffset and writing it into the EEPROM Offset and EEPROM Backup registers (see [Frequency OFFSET Correction](#)).

Table 57 EEOffset Value (0x36h, 0x37h)

6.18. USER EEPROM

00h – 2Ah – User EEPROM.

43 Bytes of User EEPROM for general purpose storage are provided. Read: Always readable. Write: Can be write-protected by password.

Address	Function	Conv.	Bit 7	Bit 6	Bit 5	Bit 4	Bit 3	Bit 2	Bit 1	Bit 0
00h to 2Ah	User EEPROM	R/WP	43 Bytes of non-volatile User EEPROM							

Table 58 User EEPROM (0x00h to 2Ah).

6.19. MANUFACTURER EEPROM

2Ch – 2Fh and 38h to 3Fh – Manufacturer EEPROM.

This registers are Protected. Not readable, but normal address pointer incrementing.

Address	Function	Conv.	Bit 7	Bit 6	Bit 5	Bit 4	Bit 3	Bit 2	Bit 1	Bit 0
2Ch to 2Fh	EEPROM RESERVED	Prot.	4 Bytes of non-volatile Manufacturer EEPROM							
38h to 3Fh	EEPROM RESERVED	Prot.	8 Bytes of non-volatile Manufacturer EEPROM							

Table 59 Manufacturer EEPROM (0x2Ch to 2Fh and 38h to 3Fh).

6.20. REGISTER RESET VALUES SUMMARY

Reset values; RAM, Address 00h to 3Fh:

Address	Function	Conv.	Bit 7	Bit 6	Bit 5	Bit 4	Bit 3	Bit 2	Bit 1	Bit 0
00h	Seconds	R/WP	0	0	0	0	0	0	0	0
01h	Minutes	R/WP	0	0	0	0	0	0	0	0
02h	Hours (24h / 12h)	R/WP	0	0	0	0	0	0	0	0
03h	Weekday	R/WP	0	0	0	0	0	0	0	0
04h	Date	R/WP	0	0	0	0	0	0	0	1
05h	Month	R/WP	0	0	0	0	0	0	0	1
06h	Year	R/WP	0	0	0	0	0	0	0	0
07h	Minutes Alarm	R/WP	1	0	0	0	0	0	0	0
08h	Hours Alarm (24h / 12h)	R/WP	1	0	0	0	0	0	0	0
09h	Weekday Alarm / Date Alarm	R/WP	1	0	0	0	0	0	0	0
0Ah	Timer Value 0	R/WP	0	0	0	0	0	0	0	0
0Bh	Timer Value 1	R/WP	0	0	0	0	0	0	0	0
0Ch	Timer Status 0	R	0	0	0	0	0	0	0	0
0Dh	Timer Status 1 shadow	R	0	0	0	0	0	0	0	0
0Eh	Status	R/WP	1 → 0	0	0	0	0	0	X	1
0Fh	Control 1	R/WP	0	0	0	0	0	0	0	0
10h	Control 2	R/WP	0	0	0	0	0	0	0	0
11h	GP Bits	R/WP	0	0	0	0	0	0	0	0
12h	Clock Int. Mask	R/WP	0	0	0	0	0	0	0	0
13h	Event Control	R/WP	0	0	0	0	0	0	0	0
14h	Count TS	R	0	0	0	0	0	0	0	0
15h	Seconds TS	R	0	0	0	0	0	0	0	0
16h	Minutes TS	R	0	0	0	0	0	0	0	0
17h	Hours TS	R	0	0	0	0	0	0	0	0
18h	Date TS	R	0	0	0	0	0	0	0	0
19h	Month TS	R	0	0	0	0	0	0	0	0
1Ah	Year TS	R	0	0	0	0	0	0	0	0
1Bh	UNIX Time 0	R/WP	0	0	0	0	0	0	0	0
1Ch	UNIX Time 1	R/WP	0	0	0	0	0	0	0	0
1Dh	UNIX Time 2	R/WP	0	0	0	0	0	0	0	0
1Eh	UNIX Time 3	R/WP	0	0	0	0	0	0	0	0
1Fh	User RAM 1	R/WP	0	0	0	0	0	0	0	0
20h	User RAM 2	R/WP	0	0	0	0	0	0	0	0
21h	Password 1	W	0	0	0	0	0	0	0	0
22h	Password 2	W	0	0	0	0	0	0	0	0
23h	Password 3	W	0	0	0	0	0	0	0	0
24h	Password 4	W	0	0	0	0	0	0	0	0
25h	EEPROM Addr.	R/WP	0	0	0	0	0	0	0	0
26h	EEPROM Data	R/WP	X	X	X	X	X	X	X	X
27h	EEPROM Com.	WP	0	0	0	0	0	0	0	0
28h	ID	R	Preconfigured Value				Preconfigured Value			
29h and 2Ah	Non-existing		Non-existing RAM address (will be skipped by address pointer)							
2Ch to 2Fh	RESERVED	Prot.	RESERVED (not readable, but normal address pointer incrementing)							
38h to 3Fh	RESERVED	Prot.	RESERVED (not readable, but normal address pointer incrementing)							

X = not defined

Table 60 Reset Values; RAM (00h to 3Fh).

Default values on delivery; Configuration EEPROM with RAM mirror, Address 2Bh and 30h to 37h:

Address	Function	Conv.	Bit 7	Bit 6	Bit 5	Bit 4	Bit 3	Bit 2	Bit 1	Bit 0
2Bh	EEPROM RESERVED	R/WP	X	X	X	X	X	X	X	X
30h	EEPROM PW Enable	R/WP	0	0	0	0	0	0	0	0
31h	EEPROM Password 0	WP	0	0	0	0	0	0	0	0
32h	EEPROM Password 1	WP	0	0	0	0	0	0	0	0
33h	EEPROM Password 2	WP	0	0	0	0	0	0	0	0
34h	EEPROM Password 3	WP	0	0	0	0	0	0	0	0
35h	EEPROM Fout	R/WP	1	1	0	0	0	0	0	0
36h	EEPROM Offset	R/WP	0	0	0	0	0	0	0	0
37h	EEPROM Backup	R/WP	0	0	0	1	0	0	0	0

X = not defined

Table 61 Configuration EEPROM (0x2Bh and 0x30h to 37h).

Default values on delivery; User EEPROM, Address 00h to 2Ah:

Address	Function	Conv.	Bit 7	Bit 6	Bit 5	Bit 4	Bit 3	Bit 2	Bit 1	Bit 0
00h to 2Ah	User EEPROM	R/WP	00h							

Table 62 Default values: User EEPROM (0x00h to 2Ah).

Default values on delivery; Manufacturer EEPROM, Address 2Ch to 2Fh and 38h to 3Fh:

Address	Function	Conv.	Bit 7	Bit 6	Bit 5	Bit 4	Bit 3	Bit 2	Bit 1	Bit 0
2Ch to 2Fh	EEPROM RESERVED	Prot..	XXh							
38h to 3Fh	EEPROM RESERVED	Prot..	XXh							

X = not defined

Table 63 Default values: Manufacturer EEPROM (0x2Ch to 2Fh and 38h to 3Fh).

EM3028 reset values after power on (RAM) and default values on delivery (EEPROM):

RAM, reset values:

Time (hh:mm:ss)	=	00:00:00
Date (YY-MM-DD)	=	00-01-01
Weekday	=	0
Hour mode	=	24 hour mode (0 to 23)
Count TS	=	0 (read only)
Time TS (hh:mm:ss)	=	00:00:00 (read only)
Date TS (YY-MM-DD)	=	00-00-00 (read only)
UNIX Time	=	00000000h
Alarm function	=	disabled, weekday is selected
Timer function	=	disabled, Timer Frequency = 4096 Hz, Single Mode selected
Update function	=	Second update is selected
Ext. Event function	=	LOW level is regarded as External Event on pin EVI, filtering on EVI pin disabled, first event recorded is enabled
Time Stamp function	=	disabled, Ext. Event selected, Time Stamp overwrite disabled, Time Stamp Reset disabled
EEPROM Memory Refresh	=	enabled
Reset function	=	disabled
Interrupts	=	disabled
EEbusy status bit	=	1 → 0 (1 for the time of ~66 ms, then it is cleared to 0 automatically)
EVF Flag	=	0 or 1 (0 if High level is detected on EVI pin; 1 if Low level is detected)
PORF Flag	=	1 (can be cleared by writing 0 to the bit)
Int. Controlled Clock	=	disabled, no interrupt selected
Password	=	00000000h (write only)
EEPROM Address	=	00h
EEPROM Data	=	XXh
EEPROM Commands	=	00h (first command) (write only)
ID	=	Preconfigured Value (read only)
General Purpose Bit	=	0 (7 bits)
User RAM 1, 2	=	00h (2 bytes)

Configuration EEPROM with RAM mirror, default values on delivery:

EEPROM RESERVED	=	Preconfigured Value (must not be overwritten)
EEPROM Password Enable	=	disabled
EEPROM Password	=	00000000h (write only)
FOUT	=	enabled, synchronization enabled, F = 32.768 kHz
Power On Reset Interrupt	=	disabled
EEOffset value	=	0 (9 bits)
Backup Switchover	=	disabled, interrupt disabled, Fast Edge Detection enabled
Trickle charger	=	disabled, TCR = 1 kΩ selected

User EEPROM, default values on delivery:

User EEPROM (43 Bytes)	=	00h
------------------------	---	-----

Manufacturer EEPROM, Address 2Ch to 2Fh and 38h to 3Fh, default values on delivery:

EEPROM RESERVED	=	XXh (protected)
-----------------	---	-----------------

7. DETAILED FUNCTIONAL DESCRIPTION

7.1. POWER ON RESET (POR)

The power on reset (POR) is generated at start-up (see [POWER ON](#)). All RAM registers including the Counter Registers are initialized to their reset values and the Configuration EEPROM registers with the RAM mirror registers are set to their preset default values. At power up a refresh of the RAM mirror values by the values in the Configuration EEPROM is automatically generated. The time of this first refreshment is ~66 ms. The EEBusy bit in the Status register (0Eh) can be used to monitor the status of the refreshment (see [Register Reset Values Summary](#)).

The Power On Reset Flag PORF indicates the occurrence of a voltage drop of the internal power supply voltage below V_{POR} threshold needed to cause the generation of the device POR. A PORF value of 1 indicates that the voltage had dropped below the threshold level V_{POR} and that the time information is corrupted. The value 1 is retained until a 0 is written by the user.

When PORIE bit (EEPROM 35h) is set and the PORF flag was cleared beforehand, an interrupt signal on nINT pin can be generated when a Power On Reset occurs (see [POWER ON RESET Interrupt Function](#)).

7.2. AUTOMATIC BACKUP SWITCHOVER FUNCTION

Basic Hardware Definitions:

- The EM3028 has two power supply pins.
 - V_{DD} is the main power supply input pin.
 - V_{BACKUP} is the backup power supply input pin.
- V_{DDSW} is the backup switchover threshold voltage. The typical value is 2.0 V.
- A debounce logic provides a 122 μ s – 183 μ s debounce time t_{DEB} , which will filter V_{DD} oscillation when the backup switchover will switch back from V_{BACKUP} to V_{DD} .
- The FEDE bit (EEPROM 37h) should always be set to 1, so that Fast Edge Detection (≥ 7 V/ms) is always enabled. – Default value on delivery

Switchover Modes:

The EM3028 has four backup switchover modes. The desired mode can be selected by the BSM field in the Configuration EEPROM, see [EEPROM BACKUP Register](#):

- BSM = 00. Backup switchover disabled (default value on delivery), see [SWITCHOVER Disabled](#).
- BSM = 01. Direct Switching Mode (DSM): when $V_{DD} < V_{BACKUP}$, switchover occurs from V_{DD} to V_{BACKUP} without requiring V_{DD} to drop below V_{DDSW} , see [Direct Switching Mode \(DSM\)](#).
- BSM = 10. Standby mode: when $V_{DD} < V_{BACKUP}$ (backup battery charged, no V_{DD}), the device enters the standby mode and draw any current from the backup source, see [STANDBY MODE](#).
- BSM = 11. Level Switching Mode (LSM): when $V_{DD} < V_{BACKUP}$ AND $V_{DD} < V_{DDSW}$ (AND $V_{BACKUP} > V_{DDSW}$), switchover occurs from V_{DD} to V_{BACKUP} , see [Level Switching Mode \(LSM\)](#).
-

Function Overview:

When a valid backup switchover condition occurs (direct or level switching mode) and the internal power supply switches to the V_{BACKUP} voltage (VBACKUP Power state) the following sequence applies:

- The Backup Switch Flag BSF is set and, if BSIE bit is 1 (EEPROM 37h), an interrupt will be generated on nINT pin and remains as long as BSF is not cleared to 0. If BSIE is 0 no interrupt will be generated (see [Automatic BACKUP Switchover Interrupt Function](#)).
- The I²C-bus interface is automatically disabled (high impedance) and reset.
- EVI input remains active for interrupt generation, interrupt driven clock output and time stamp function
- FOUT pin is held LOW during VBACKUP Power state.
- The interrupt output pin nINT remains active in VBACKUP Power state for any previously configured interrupt condition.
- Going into VBACKUP Power state can be used as a time stamp condition (see [TIME STAMP Function](#)).
- The backup switchover condition can also be used to enable the clock output on FOUT pin automatically, when again in VDD Power state (see [Automatic BACKUP Switchover Interrupt Function](#)).

The Backup Switch Flag BSF can be cleared using the I²C-bus interface as soon as the circuit resumes from VBACKUP Power state and switched back to V_{DD}.

Note: After the device has switched back from VBACKUP Power state to V_{DD} Power state the I²C interface has to be reinitialized by sending a STOP followed by a START (see also **I²C-BUS in Switchover Condition**).

7.2.1. SWITCHOVER DISABLED

The automatic backup switchover function is disabled when the BSM field (EEPROM 37h) is set to 00 (default value on delivery). Used when only one power supply is available.

- The power supply is applied on V_{DD} pin.
- V_{BACKUP} pin must be tied to V_{SS} with a 10 kΩ resistor.
- The battery flag BSF is always logic 0.

7.2.2. DIRECT SWITCHING MODE (DSM)

This mode is selected with BSM = 01 (EEPROM 37h).

- If V_{DD} > V_{BACKUP} the internal power supply is V_{DD}.
- If V_{DD} < V_{BACKUP} the internal power supply is V_{BACKUP}.

The Direct Switching Mode is useful in systems where V_{DD} is higher than V_{BACKUP} at all times (for example, V_{DD} = 5.0 V, V_{BACKUP} = 3.5 V). If the V_{DD} and V_{BACKUP} values are similar (for example, V_{DD} = 3.3 V, V_{BACKUP} ≥ 3.0V), the Direct Switching Mode is not recommended.

In Direct Switching Mode, the power consumption is reduced compared to the Level Switching Mode (LSM) because the monitoring of V_{BACKUP} and V_{DSSW} is not performed (typical I_{VDD:DIRECT} = 95 nA).

Note that the circuit needs in worst case 2 ms to react when the mode is changed from Standby Mode or Backup Switchover Disabled to DSM.

Backup switchover in Direct Switching Mode and with Backup Switchover Interrupt enabled with BSIE = 1 (EEPROM 37h):

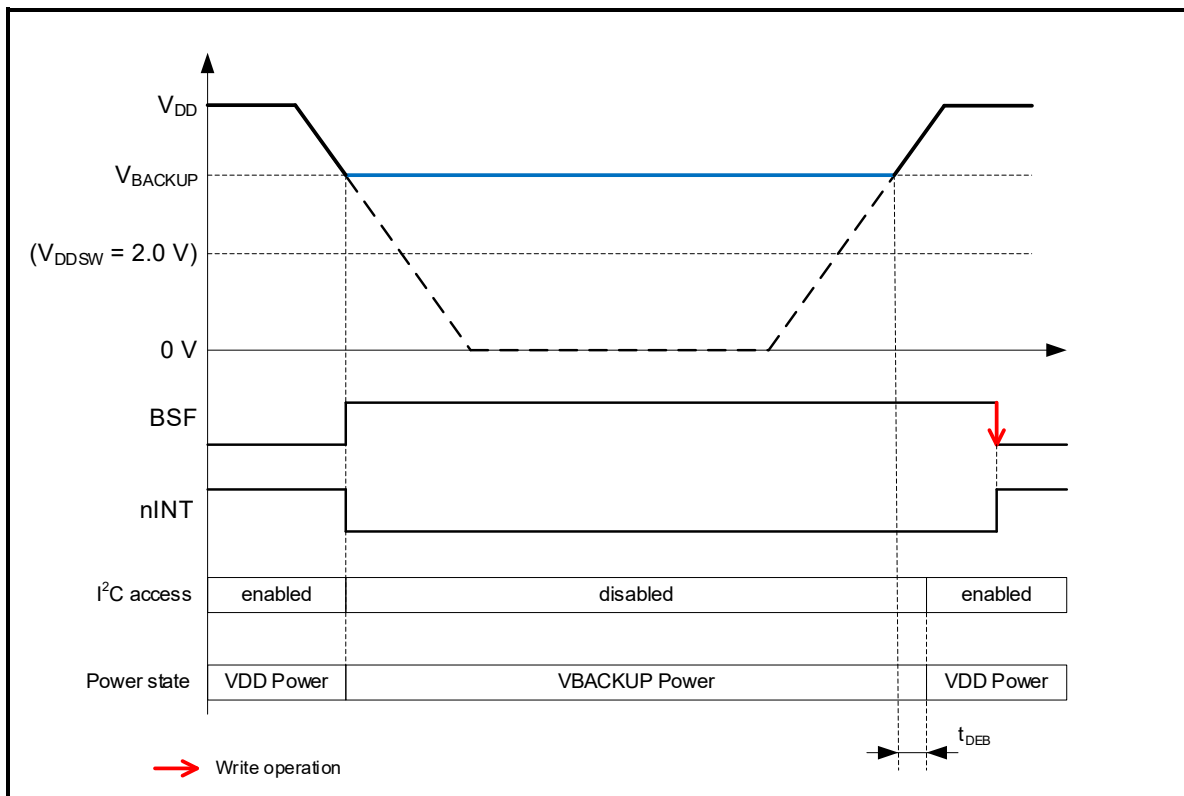


Figure 7-1 Direct Switching Mode

7.2.3. STANDBY MODE

When the device is first powered up from the backup supply (V_{BACKUP}) but without a main supply (V_{DD}), the device automatically enters the Standby Mode. In Standby Mode the device does not draw any power from the backup source until the device is powered up from the main power supply V_{DD} .

It is also possible to enter into Standby Mode when the device is already supplied by the main power supply V_{DD} and a backup supply V_{BACKUP} is connected. To enter the Standby Mode, the BSM field (EEPROM 37h) has to be set logic 10. Then the main power supply V_{DD} must be removed. As a result of it, the device enters the Standby Mode and does not draw any current from the backup supply before it is powered up again from main supply V_{DD} and set to a switchover mode.

7.2.4. LEVEL SWITCHING MODE (LSM)

This mode is selected with BSM = 11 (EEPROM 37h).

- If $V_{DD} > V_{BACKUP}$ OR $V_{DD} > V_{DDSW}$, the internal power supply is V_{DD} .
- If $V_{DD} < V_{BACKUP}$ AND $V_{DD} < V_{DDSW}$ (AND $V_{BACKUP} > V_{DDSW}$), the internal power supply is V_{BACKUP} .

In Level Switching Mode, the power consumption is increased compared to the Direct Switching Mode (DSM) because of the monitoring of V_{BACKUP} and V_{DDSW} (typical $I_{VDD:LEVEL} = 115 \text{ nA}$). See also typical characteristics in level switching mode in section **Electrical Characteristics**.

Note that the circuit needs in worst case 15.625 ms to react when the mode is changed from Standby Mode or Backup Switchover Disabled to LSM.

Backup switchover in Level Switching Mode and with Backup Switchover Interrupt enabled with BSIE = 1 (EEPROM 37h):

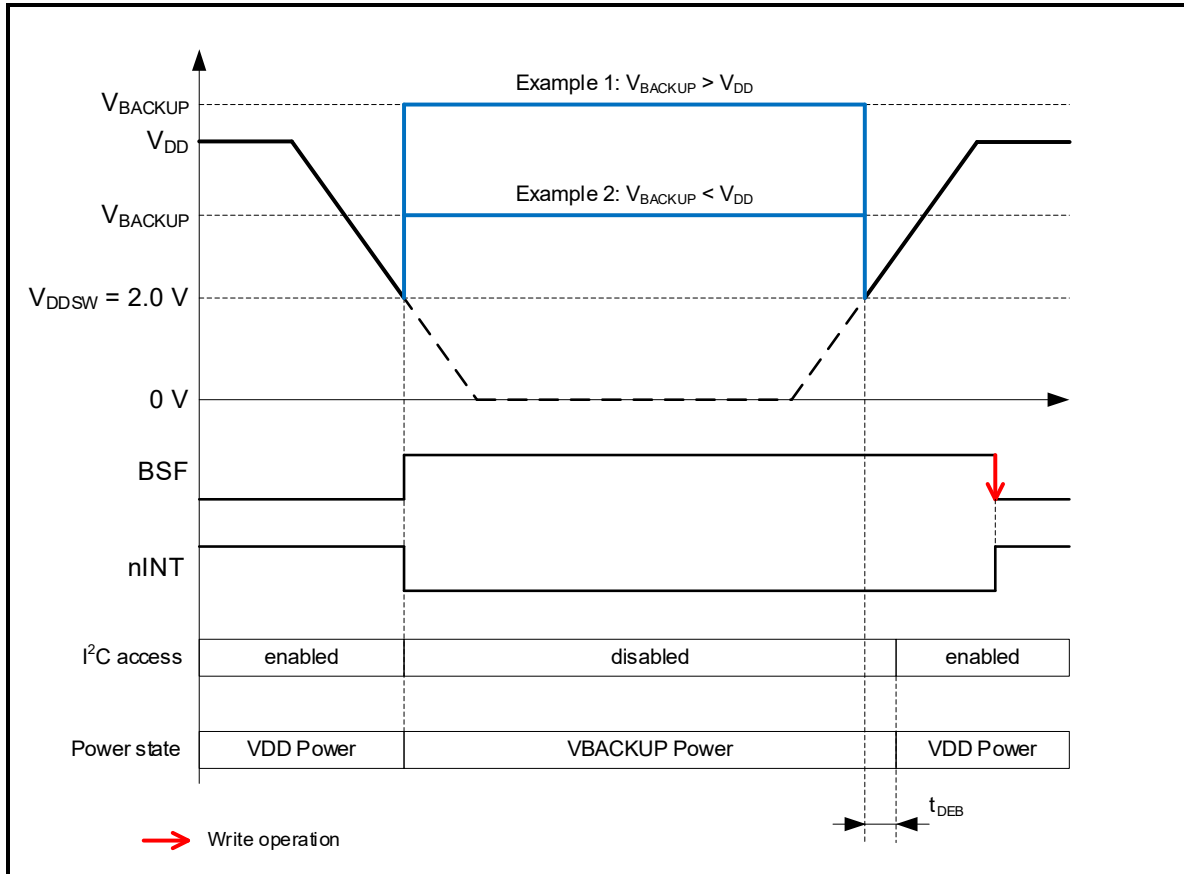


Figure 7-2 Level Switching Mode

7.3. TRICKLE CHARGER

The device supporting the V_{BACKUP} pin include a trickle charging circuit which allows a battery or supercapacitor connected to the V_{BACKUP} pin to be charged from the power supply connected to the V_{DD} pin. The circuit of the Trickle Charger is shown in the following Figure. The Trickle Charger is enabled with bit TCE (EEPROM 37h). The series current limiting resistor is selected by the TCR field (EEPROM 37h) as shown in the Figure (default value on delivery is 1 k Ω). A schottky diode, with a typical voltage drop of 0.25 V, is inserted in the charging path.

Trickle Charger:

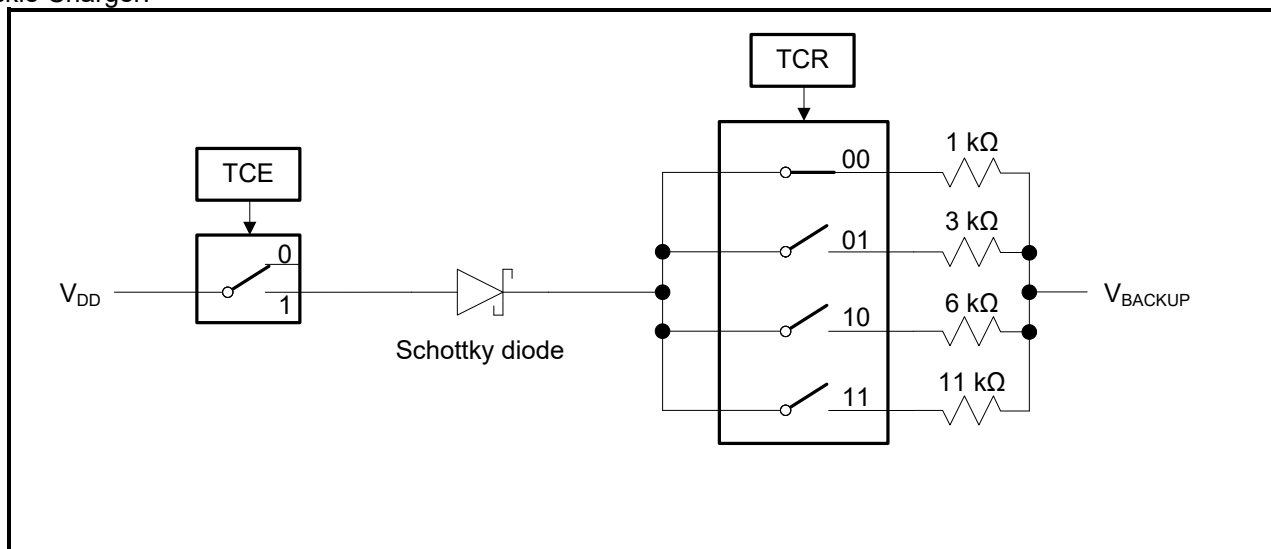


Figure 7-3 Trickle Charger configuration

The trickle charger is disabled when the device is in V_{BACKUP} Power state.

7.4. PROGRAMMABLE CLOCK OUTPUT

Six different frequencies or the countdown timer interrupt signal can be output on FOUT pin, the signal selection is done in the FD field (EEPROM 35h).

- 32.768 kHz, direct from Xtal oscillator, not tuned.
- 8192 Hz, 1024 Hz, 64 Hz, 32 Hz, 1 Hz; divided Xtal oscillator frequencies, digitally tuned according to the oscillator offset value EEOffset (EEPROM 36h and 37h).
- Timer interrupt is controlled by the Countdown Timer Control Registers and the Control 1 register.

The initial original clock signal (32.768 kHz) is initiated for switching on/off at his negative edge, a subsequently selected clock signal is taking over on his negative edge by controlling bits CLKF, CLKOE and FD field, in-between FOUT is tied to V_{SS} .

FOUT is tied to V_{SS} in V_{BACKUP} Power state independent of the FOUT configuration settings.

The frequency output can be controlled directly via the I²C-bus interface commands (normal operation) or can be interrupt driven to allow waking up an external system by supplying a clock.

At POR the synchronization function is active since the bit CLKS_Y is set to 1 (default), the 32.768 kHz frequency is output to FOUT pin since the bit CLKOE is set to 1 (default) and FD field is set to 000 (default). Hint: These are the default values on delivery, stored in the Configuration EEPROM with RAM mirror. To customize these POR values, the user can change the values in the Configuration EEPROM.

7.4.1. FOUT FREQUENCY SELECTION

A programmable square wave is available at pin FOUT. Operation is controlled by the FD field (EEPROM 35h). Frequencies from 32.768 kHz (Default value on delivery) to 1 Hz and countdown timer interrupt can be generated for use as a system clock, microcontroller clock, input to a charge pump, or for calibration of the crystal oscillator.

Pin FOUT is a push-pull output that is enabled at power on (Default value on delivery). FOUT can be disabled by setting CLKOE bit to 0 or FD field to 111. When disabled, the FOUT pin is LOW.

The RESET bit function can affect the FOUT signal depending on the selected frequency. When 1 is written to the RESET bit and the FOUT is enabled, the FOUT pin goes LOW for the frequencies 1024 Hz to 1 Hz (for more details, see **RESET bit Function**).

FOUT Frequency Selection:

FD	FOUT Frequency Selection	When 1 is written to the RESET bit
000	32.768 kHz –Default value on delivery	No effect
001	8192 Hz (1)	No effect
010	1024 Hz (1)	FOUT goes LOW
011	64 Hz (1)	FOUT goes LOW
100	32 Hz (1)	FOUT goes LOW
101	1 Hz (1)	FOUT goes LOW
110	Predefined periodic countdown timer interrupt (1) (2)	FOUT goes LOW
111	FOUT = LOW	No effect

(1) 8192 Hz to 1 Hz clock pulses and the timer interrupt pulses can be affected by correction pulses (see **Frequency OFFSET Correction**).

(2) CLKSY bit has no effect.

7.4.2. NORMAL CLOCK OUTPUT

Writing bit CLKOE to 1 will drive the selected frequency on FOUT, writing CLKOE to 0 will clear the selected frequency on FOUT.

7.4.3. INTERRUPT CONTROLLED CLOCK OUTPUT

Writing 1 to CLKIE the occurrence of the selected interrupt condition allows frequency output on FOUT. This function allows waking up an external system by outputting a clock.

Writing 0 to CLKIE will disable new interrupts from driving frequencies on FOUT, but if there is already an active interrupt driven frequency output (CLKF flag is set), the active frequency output will not be stopped. Writing the CLKF flag to 0 will clear the flag and frequency output will stop. Normal and Interrupt controlled clock output can be activated concurrently.

7.4.4. SYNCHRONIZED ENABLE/DISABLE

The enabled Synchronized FOUT Enable/Disable function (CLKSY = 1) consists of two sub-functions.

- Synchronized FOUT enable. For enabling clock output on FOUT pin the internal first negative clock edge of the selected clock source (FD field) is detected after CLKF or CLKOE are set.
- Synchronized FOUT disable. Clock output on FOUT will be disabled at the next negative clock edge of the selected clock source (FD field) after both CLKF and CLKOE are cleared and after the I²C-bus interface stop condition. When disabled, FOUT is tied to V_{SS}.

(CLKF and CLKOE = 0 → disable condition → next negative clock edge → FOUT driven to V_{SS})

Synchronized FOUT Enable/Disable times (CLKSY = 1):

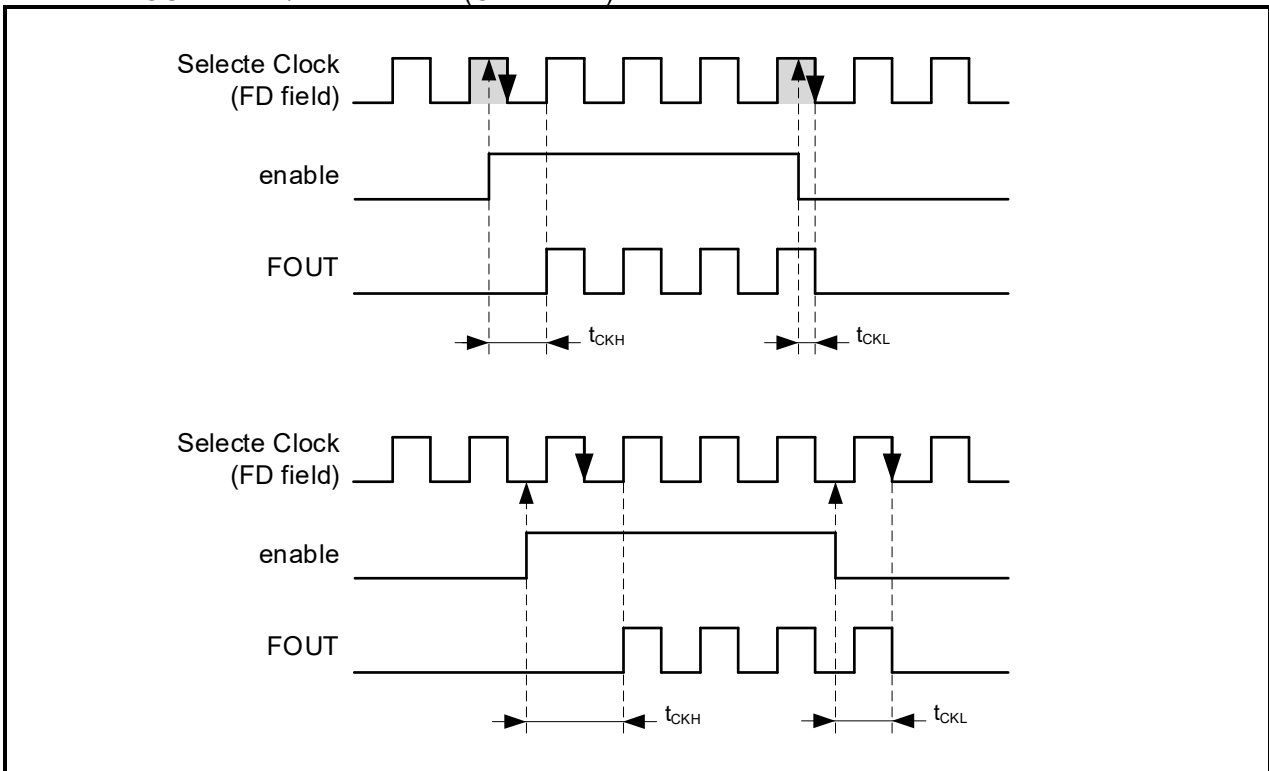


Figure 7-4 Frequency Output configuration

Hint: Glitch free frequency change on FOUT requires clearing flag CLKF and bit CLKOE to 0 before the new clock is selected in FD field.

(CLKF and CLKOE = 0 → disable condition → next negative clock edge → FOUT driven to V_{SS} → FD field selection → CLKF and/or CLKOE = 1 → enable condition → next negative clock edge)

7.4.5. CLOCK OUTPUT SCHEME

Complete frequency output scheme:

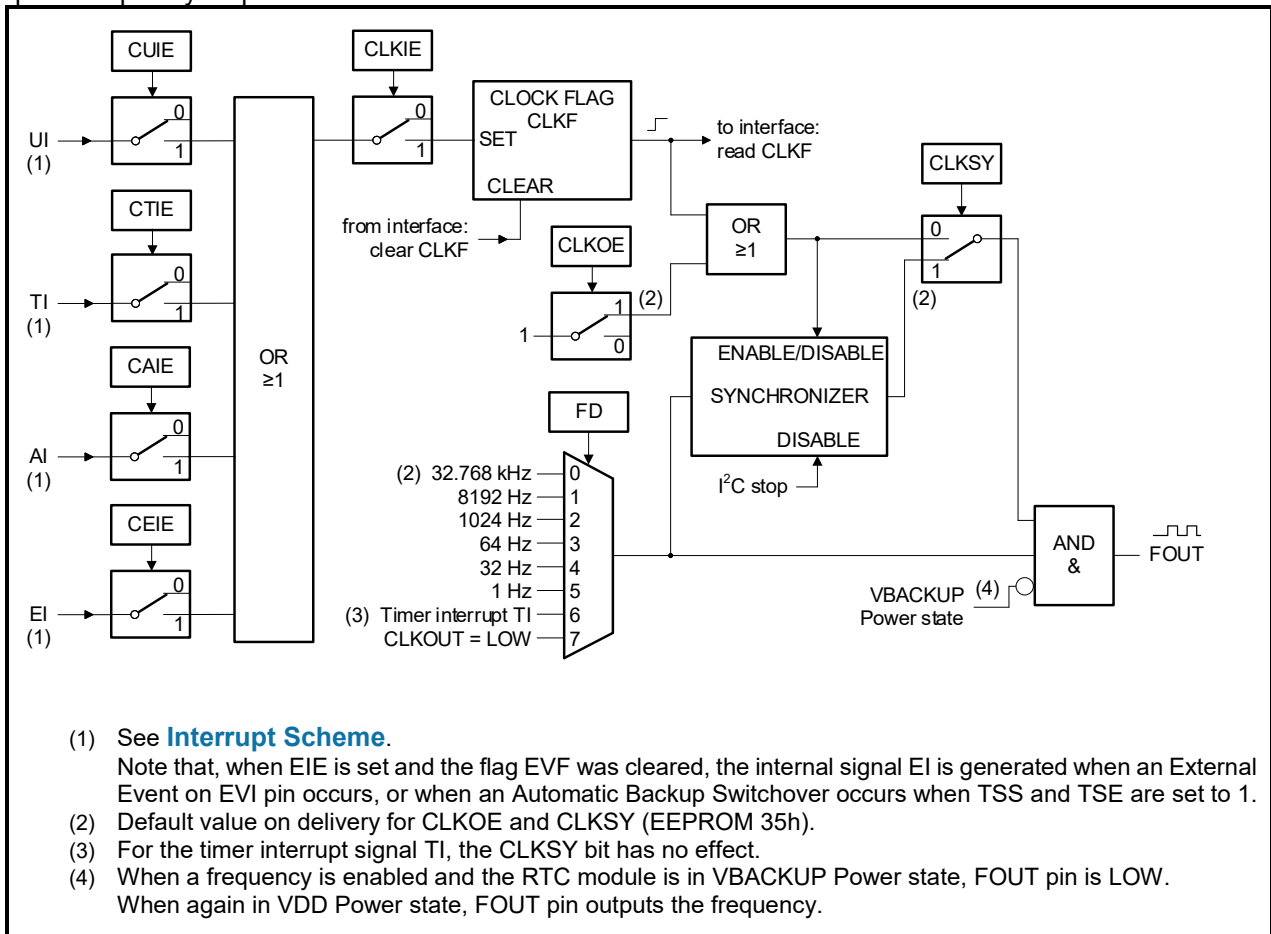


Figure 7-5 Frequency Output scheme

7.5. SETTING AND READING THE TIME

Data flow and data dependencies starting from the 1 Hz clock tick:

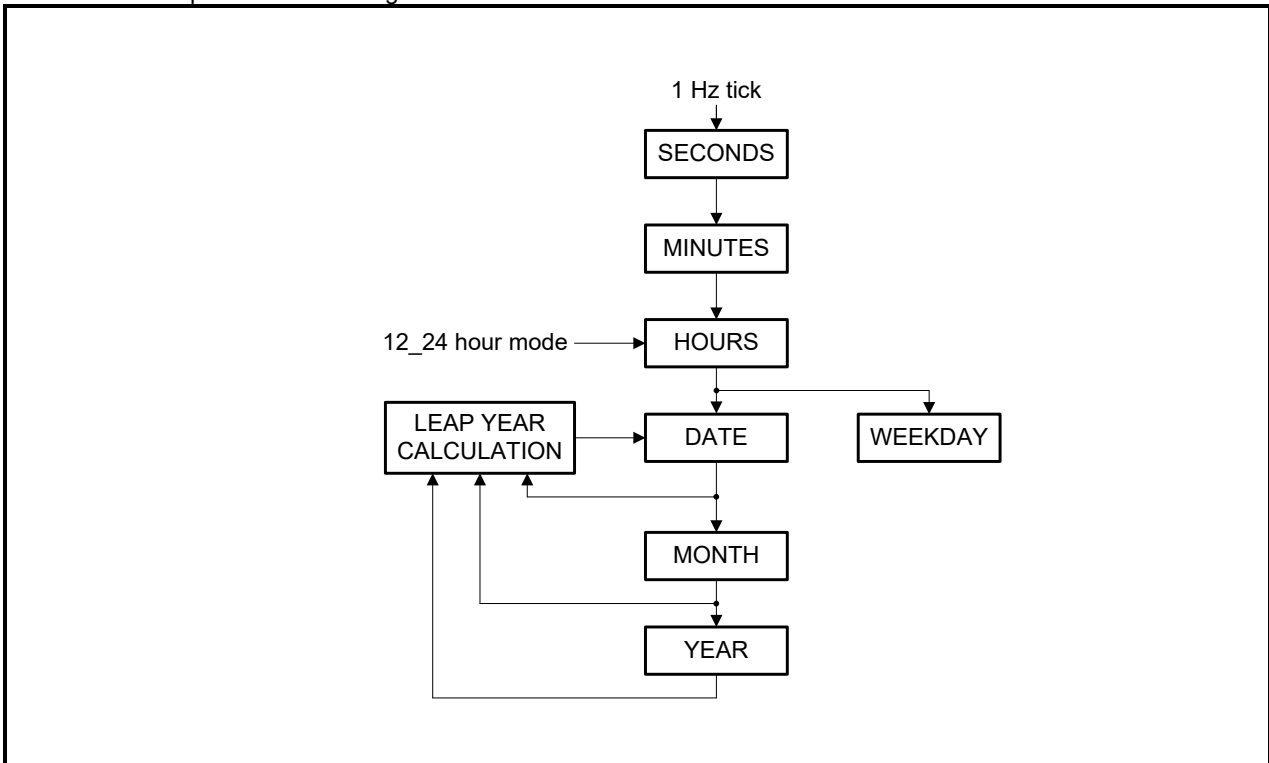


Figure 7-6 Setting and Reading the Time

During read/write operations, all clock and calendar registers (00h to 06h) are blocked for 950 ms second. The clock counter increment (1 Hz tick) is inhibited during I²C access to the EM3028 to allow coherent data values. A counter increment (maximum one 1 Hz tick) occurring during inhibition time is memorized and will be realized after the I²C stop condition.

Exception: If during the inhibition time the Seconds register was written by an I²C command the prescaler from 4096 Hz to 1 Hz will be reset. Resetting the prescaler will have an influence on the length of the current clock period on all subsequent peripherals (clock and calendar, FOUT, timer clock, update timer clock, UNIX clock, EVI input filter). Writing to the Seconds register has the same effect as setting RESET bit to 1 (see **RESET bit Function**).

When the read/write access has been terminated within 950 milliseconds ($t < 950$ ms), the time circuit is de-blocked immediately and any pending request to increment the time counters that occurred during a read access is correctly applied. Maximal one 1 Hz tick can be handled (see **Figure 7-7 Access time for Read/Write Operations**).

Access time for read/write operations:

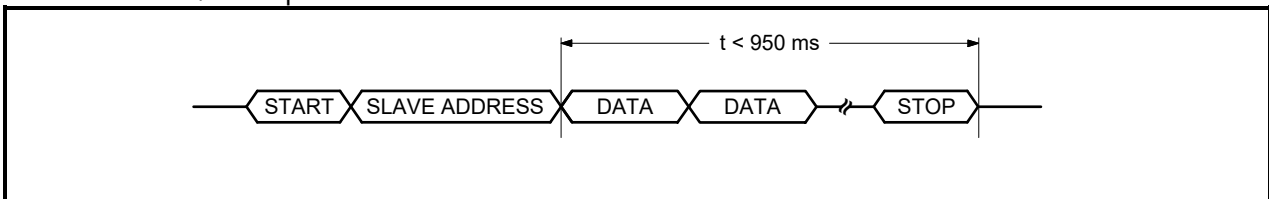


Figure 7-7 Access time for Read/Write Operations

Because of this method, it is very important to make a read or write access in one go, that is, setting or reading seconds through to years should be made in one single access. Failing to comply with this method could result in the time becoming corrupted.

7.5.1. SETTING THE TIME

Advantage of register blocking during setting the time:

- Register blocking prevents faulty writing to the clock and calendar during an I²C write access (no incrementing of time registers during the write access).
- A possible 1 Hz tick occurring during the write access will be dropped.

The divider chain is reset whenever the Seconds register is written. This feature can be used to make a synchronized time setting. The other method is to use the **RESET bit Function**).

7.5.2. READING THE TIME

Advantage of register blocking and memorization of one 1 Hz tick during reading the time:

- Register blocking prevents faulty reading of the clock and calendar during an I²C read access (no incrementing of time registers during the read access).
- After reading, one memorized 1 Hz tick can be handled. Clock and calendar are updated.
- No second reading is needed. The read data are coherent.

Hint: The UNIX Time counter does not know such register blocking (see **UNIX Time Counter**).

7.6. EEPROM READ/WRITE

7.6.1. POR REFRESH (ALL CONFIGURATION EEPROM → RAM)

Read of all Configuration EEPROM registers at Power On Reset (POR):

At power up a refresh of the RAM mirror values by the values in the Configuration EEPROM is automatically generated (see [Register Reset Values Summary](#)). The time of this first refreshment is ~66 ms. The EEbusy bit in the register Status (0Eh) can be used to monitor the status of the refreshment.

7.6.2. AUTOMATIC REFRESH (ALL CONFIGURATION EEPROM → RAM)

Read all Configuration EEPROM registers automatically:

- To keep the integrity of the configuration data, all data of the Configuration RAM are refreshed by the data in the Configuration EEPROM each 24 hours, at date increment (1 second before midnight).
- Refresh is only active when EM3028 is not in VBACKUP mode and not disabled by EERD (EEPROM Memory Refresh Disable) bit.

7.6.3. REFRESH (ALL CONFIGURATION EEPROM → RAM)

Read all Configuration EEPROM registers:

- Before starting to read the configuration stored in the EEPROM, the auto refresh of the registers from the EEPROM has to be disabled by writing 1 into the EERD control bit.
- Then the actual configuration can be read from the Configuration EEPROM registers, writing the command 00h into the register EEcmd, and then the second command 12h into the register EEcmd will start the copy of the configuration into the RAM.
- When the transfer is finished (EEbusy = 0), the user can enable again the auto refresh of the registers by writing 0 into the EERD bit in the Control 1 register.

7.6.4. UPDATE (ALL CONFIGURATION RAM → EEPROM)

Write to all Configuration EEPROM registers:

- Before starting to change the configuration stored in the EEPROM, the auto refresh of the registers from the EEPROM has to be disabled by writing 1 into the EERD control bit.
- Then the new configuration can be written into the configuration RAM registers, when the whole new configuration is in the registers, writing the command 00h into the register EEcmd, then the second command 11h into the register EEcmd will start the copy of the configuration into the EEPROM.
- When the transfer is finished (EEbusy = 0), the user can enable again the auto refresh of the registers by writing 0 into the EERD bit in the Control 1 register.

7.6.5. READ ONE EEPROM BYTE (EEPROM → RAM-EEDATA)

Read one EEPROM byte from Configuration EEPROM or User EEPROM registers:

- Before starting to read a byte in the EEPROM, the auto refresh of the registers from the EEPROM has to be disabled by writing 1 into the EERD control bit.
- To read a single byte from EEPROM, the address to be read from is put in the EEaddr register, then the command 00h is written in the EEcmd register, then the second command 22h is written in the EEcmd register and the resulting byte can be read from the EEdata register.
- When the transfer is finished (EEbusy = 0), the user can enable again the auto refresh of the registers by writing 0 into the EERD bit in the Control 1 register.

7.6.6. WRITE TO ONE EEPROM BYTE (RAM-EEDATA → EEPROM)

Write to one EEPROM byte of the Configuration EEPROM or User EEPROM registers:

- Before starting to change data stored in the EEPROM, the auto refresh of the registers from the EEPROM has to be disabled by writing 1 into the EERD control bit.
- To write a single byte to EEPROM, the address to be written to is put in the EEaddr register and the data to be written is put in the EEdata register, then the command 00h is written in the EEcmd register, then a second command 21h is written in the EEcmd register to start the EEPROM write.
- When the transfer is finished (EEbusy = 0), the user can enable again the auto refresh of the registers by writing 0 into the EERD bit in the Control 1 register.

7.6.7. EEBUSY BIT

The set EEBusy status bit (bit 7 in the Status register 0Eh) indicates that the EEPROM is currently handling a read or write request and will ignore any further commands until the current one is finished. At power up a refresh is automatically generated. The time of this first refreshment is ~66 ms. After the refreshment is finished; EEBusy is cleared to 0 automatically. The cleared EEBusy status bit indicates that the EEPROM transfer is finished.

To prevent access collision between the internal automatic EEPROM refresh cycle (EERD = 0) and external EEPROM read/write access through interface the following procedures can be applied.

- Set EERD = 1 Automatic EEPROM Refresh needs to be disabled before EEPROM access.
- Check for EEBusy = 0 Access EEPROM only if not busy.
- Clear EERD = 0 It is recommended to enable Automatic EEPROM Refresh at the end of read/write access.
- Write EEPROM Wait 10 ms after each written EEPROM register before checking for EEBusy = 0 to allow internal data transfer.

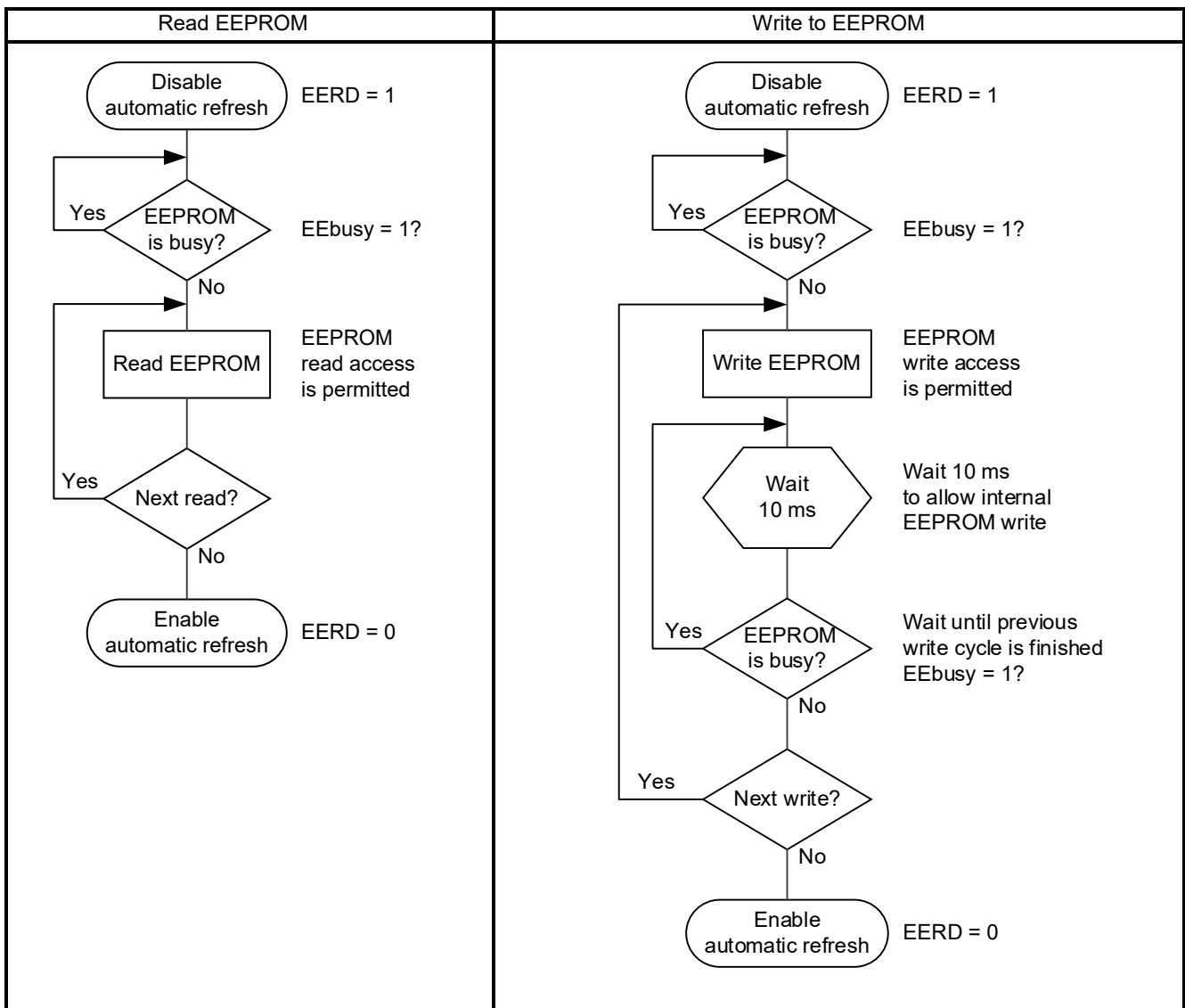


Figure 7-8 EEBusy bit

Note: In VDD Power state a minimum voltage of $V_{PROG} = 1.5\text{ V}$ during the whole EEPROM write procedure is required; i.e. until EEBusy = 0.

7.6.8. EEPROM READ/WRITE CONDITIONS

During a read/write of the EEPROM, if the V_{DD} supply drops, the device will continue to operate and communicate until a switchover to V_{BACKUP} occurs (in DSM or LSM mode). It is not recommended to operate during this time and all I²C communication should be halted as soon as V_{DD} failure is detected.

During the time that data is being written to the EEPROM, V_{DD} should remain above the minimum programming voltage $V_{PROG} = 1.5$ V. If at any time V_{DD} drops below this voltage, the data written to the device get corrupted.

To program the EEPROM, the backup switchover circuit must switch back to the main power supply V_{DD} . See also **Automatic BACKUP Switchover Interrupt Function**.

7.7. USE OF THE CONFIGURATION EEPROM WITH RAM MIRROR REGISTERS

The best practice method to use the Configuration EEPROM with RAM mirror registers at addresses 2Bh and 30h to 37h is to make all Configuration settings in the RAM first and then to update all Configuration EEPROMs by the Update command EEcmd = 11h, see **Update (ALL CONFIGURATION RAM → EEPROM)**.

Edit the Configuration settings:

1. Enter the correct password PW (PW = EEPW) to unlock write protection (PW0 to PW3)
2. Disable automatic refresh (EERD = 1)
3. Edit Configuration settings (RAM)
 - a. For changing Password EEPW, see **User Programmable Password**
4. Enter correct password PW (PW = EEPW) to unlock write protection (PW0 to PW3)
5. Update EEPROM (all Configuration RAM → EEPROM) with EEcmd = 00h followed by 11h
6. Enable automatic refresh (EERD = 0)
7. Enter an incorrect password PW (PW ≠ EEPW) to (PW0 to PW3) to lock the device

7.8. INTERRUPT OUTPUT

The interrupt pin nINT can be triggered by six different functions:

- Periodic Countdown Timer Interrupt F
- Periodic Time Update Interrupt F
- Alarm Interrupt F
- External Event F
- Automatic BACKUP Switchover Interrupt F
- POWER ON RESET Interrupt F

7.8.1. SERVICING INTERRUPTS

The nINT pin can indicate six types of interrupts. It outputs the logic OR operation result of these interrupt outputs. When an interrupt is detected (when nINT pin produces a negative pulse or is at low level), the TF, UF, AF, EVF, BSF and PORF flags can be read to determine which interrupt event has occurred.

To keep nINT pin from changing to low level, clear the TIE, UIE, AIE, EIE and BSIE (EEPROM 37h) and PORIE (EEPROM 35h) bits. To check whether an event has occurred without outputting any interrupts via the nINT pin, software can read the TF, UF, AF, EVF, BSF and PORF interrupt flags (polling).

Caution: The EVF flag is also set by an event of the Backup Switchover function when bits TSS and TSE are set to 1.

7.8.2. INTERRUPT SCHEME

Interrupt Scheme (Part 1)

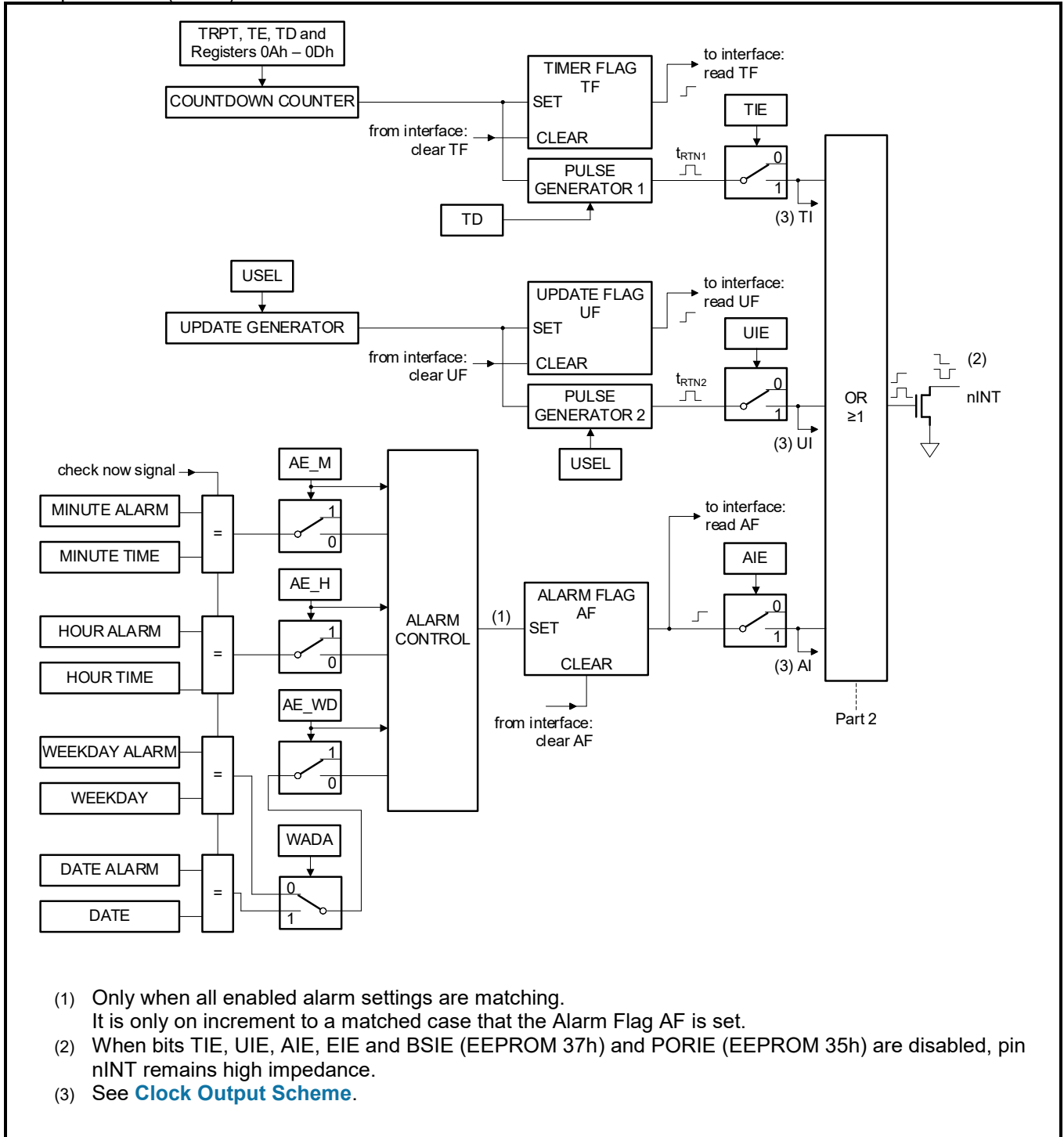
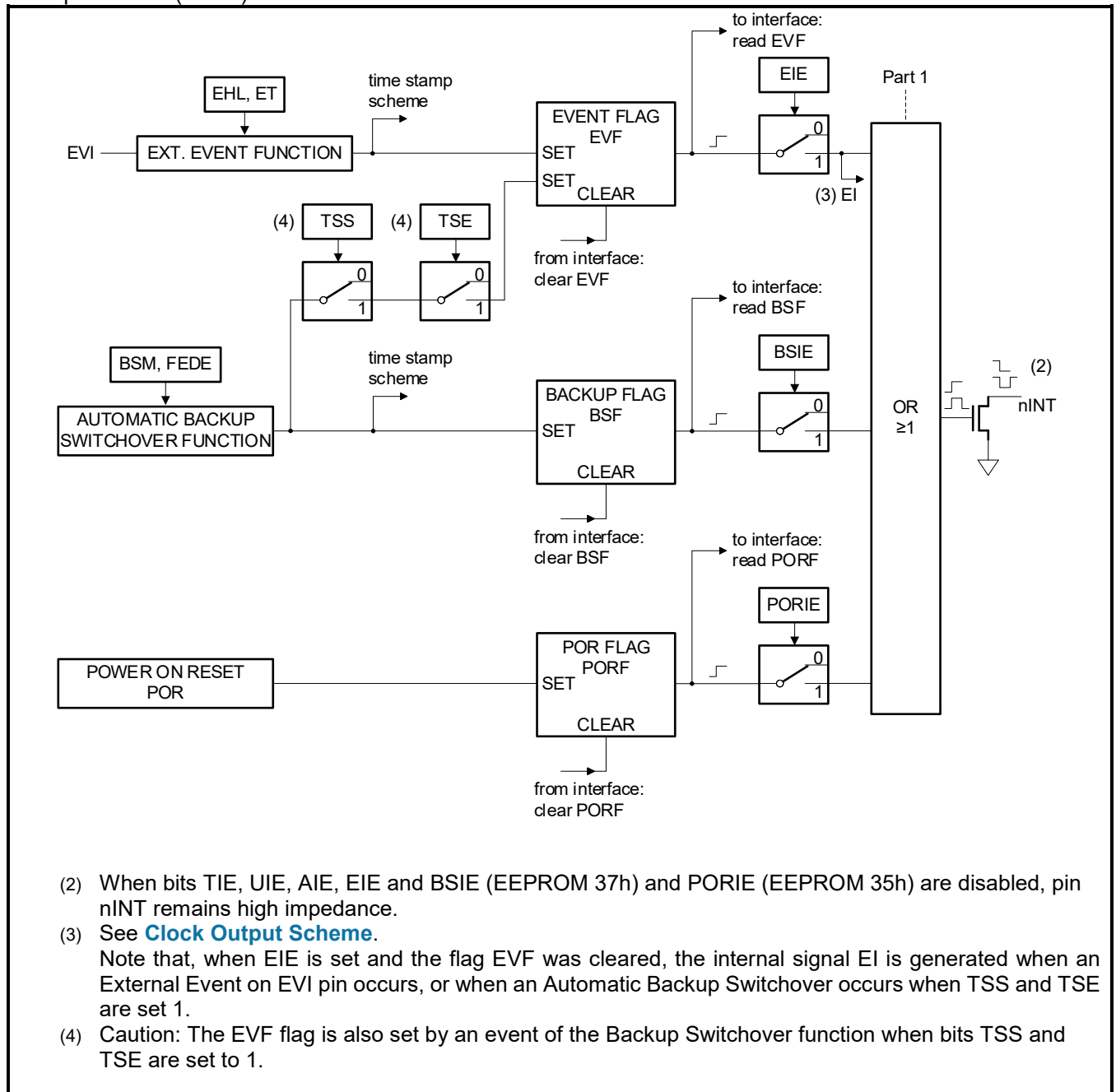


Figure 7-9 Interrupt Scheme (Part 1)

Interrupt Scheme (Part 2)



- (2) When bits TIE, UIE, AIE, EIE and BSIE (EEPROM 37h) and PORIE (EEPROM 35h) are disabled, pin nINT remains high impedance.
- (3) See [Clock Output Scheme](#).
Note that, when EIE is set and the flag EVF was cleared, the internal signal EI is generated when an External Event on EVI pin occurs, or when an Automatic Backup Switchover occurs when TSS and TSE are set 1.
- (4) Caution: The EVF flag is also set by an event of the Backup Switchover function when bits TSS and TSE are set to 1.

Figure 7-10 Interrupt Scheme (Part 2)

7.9. PERIODIC COUNTDOWN TIMER INTERRUPT FUNCTION

The Periodic Countdown Timer Interrupt function generates an interrupt event once or periodically at any period set from 244.14 μ s to 4095 minutes.

If TRPT is set to 0 (default), Single Mode is selected. In Single Mode the counter will stop after reaching 0 and bit TE will be reset.

TRPT bit has to be set to 1 if periodic countdown is needed (Repeat Mode). In Repeat Mode the timer will be reloaded with the Timer Value from the Timer Value 0 and Timer Value 1 registers. This will repeat until TE is cleared or TRPT will be set to 0. In later case the countdown will stop when the timer reaches 0 for the next time and TE will be cleared. Loading the Timer Value with 0 stops the timer, interrupt is cleared and the flag TF is reset.

When starting the countdown timer for the first time, only the first period does not have a fixed duration. The amount of inaccuracy for the first timer period depends on the selected source clock (see [First Period Duration](#)).

When an interrupt event is generated, the nINT pin goes to the low level and the TF flag is set to 1 to indicate that an event has occurred. The output on the nINT pin is only effective if the TIE bit in the Control 2 register is set to 1. The low-level output signal on the nINT pin is automatically cleared after the Auto reset time t_{RTN1} . $t_{RTN1} = 122 \mu$ s (TD = 00) or $t_{RTN1} = 7.813$ ms (TD = 01, 10, 11).

When bit TIE is set to 1, the internal countdown timer interrupt pulse (TI) can be used to enable the clock output on FOUT pin automatically, when bits CTIE, CLKIE and CLKOE are set to 1 and a frequency is selected in the FD field. The interrupt pulses (TI) can even be used as FOUT frequency, when selecting 110 in the FD field (see [Clock Output Scheme](#)).

7.9.1. PERIODIC COUNTDOWN TIMER DIAGRAM

Diagram of the Periodic Countdown Timer Interrupt function: In Repeat Mode (TRPT = 1). Countdown Timer Signal on FOUT (CLKOE = 1 and FD = 110).

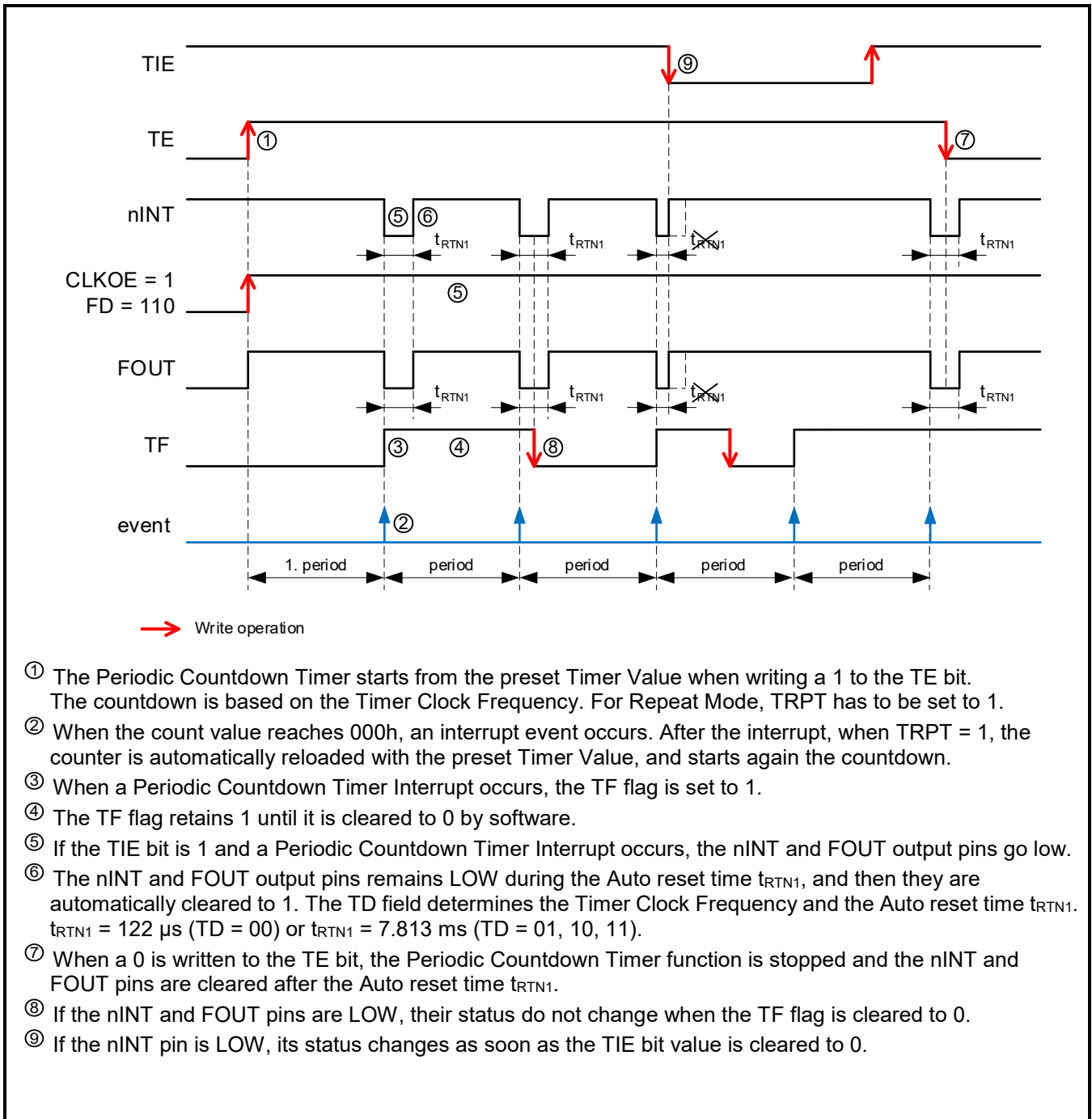


Figure 7-11 Periodic Countdown Timer Interrupt

7.9.2. USE OF THE PERIODIC COUNTDOWN TIMER INTERRUPT

The following registers, fields and bits are related to the Periodic Countdown Timer Interrupt and Automatic Clock output function:

- Timer Value 0 Register (0Ah) (see [Periodic Countdown Timer Control Registers](#))
- Timer Value 1 Register (0Bh) (see [Periodic Countdown Timer Control Registers](#))
- Timer Status 0 Register (0Ch) (see [Periodic Countdown Timer Control Registers](#))
- Timer Status 1 shadow Register (0Dh) (see [Periodic Countdown Timer Control Registers](#))
- TF flag (see [Configuration Registers](#), 0Eh – Status)
- TRPT bit, TE bit and TD field (see [Configuration Registers](#), 0Fh – Control 1)
- TIE bit (see [Configuration Registers](#), 10h – Control 2)
- CTIE bit (see [Configuration Registers](#), 12h – Clock Interrupt Mask)

For selecting Countdown Timer Signal for FOUT pin (CLKOE = 1 and FD = 110):

- CLKOE bit and FD field (see [EEPROM FOUT Register](#))

Prior to entering any timer settings for the Periodic Countdown Timer Interrupt, it is recommended to write a 0 to the TIE and TE bits to prevent inadvertent interrupts on nINT pin. When 1 is written to the RESET bit, the Periodic Countdown Timer Interrupt function is retarded. When the Periodic Countdown Timer Interrupt function is not used, one Timer Value register (0Ah) can be used as RAM byte. The Timer Clock Frequency selection field TD is used to set the countdown period (source clock) for the Periodic Countdown Timer Interrupt function (four settings are possible).

Procedure to use the Periodic Countdown Timer Interrupt function and Automatic Clock output function:

1. Initialize bits TE, TIE and TF to 0. In that order, to prevent inadvertent interrupts on nINT pin.
2. Set TRPT bit to 1 if periodic countdown is needed (Repeat Mode).
3. Choose the Timer Clock Frequency and write the corresponding value in the TD field.
4. Choose the Countdown Period based on the Timer Clock Frequency, and write the corresponding Timer Value to the registers Timer Value 0 (0Ah) and Timer Value 1 (0Bh). See following table.
5. Set the TIE bit to 1 if you want to get a hardware interrupt on nINT pin.
6. Set CTIE bit to 1 to enable clock output when a timer interrupt occurs. See also [Clock Output Scheme](#).
7. Set the TIE and CLKOE bits to 1 and the FD field to 110 if you want to get the timer signal on FOUT.
8. Set the TE bit from 0 to 1 to start the Periodic Countdown Timer. The countdown starts at the rising edge of the SCL signal after Bit 0 of the Address 0Fh is transferred. See subsequent Figure that shows the start timing.

Countdown Period in seconds:

$$\text{Countdown Period} = \frac{\text{Timer Value}}{\text{Timer Clock Frequency}}$$

Timer Value (0Ah and 0Bh)	Countdown Period			
	TD = 00 (4096 Hz)	TD = 01 (64 Hz)	TD = 10 (1 Hz)	TD = 11 (1/60 Hz)
0	-	-	-	-
1	244.14 μs	15.625 ms	1 s	1 min
2	488.28 μs	31.25 ms	2 s	2 min
:	:	:	:	:
41	10.010 ms	640.63 ms	41 s	41 min
205	50.049 ms	3.203 s	205 s	205 min
410	100.10 ms	6.406 s	410 s	410 min
2048	500.00 ms	32.000 s	2048 s	2048 min
:	:	:	:	:
4095 (FFFh)	0.9998 s	63.984 s	4095 s	4095 min

General countdown timer behavior:

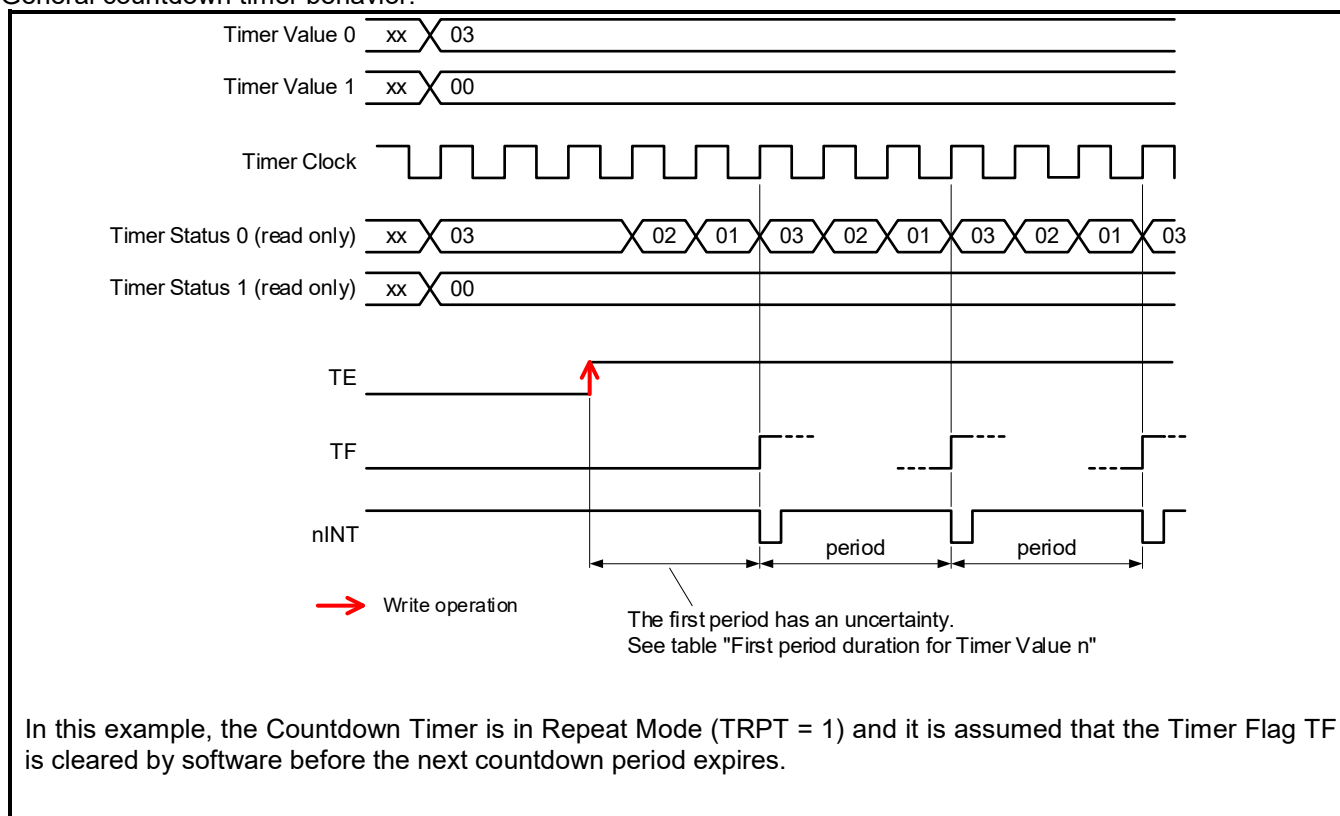


Figure 7-12 Periodic Countdown Timer Interrupt

Start timing of the Periodic Countdown Timer:

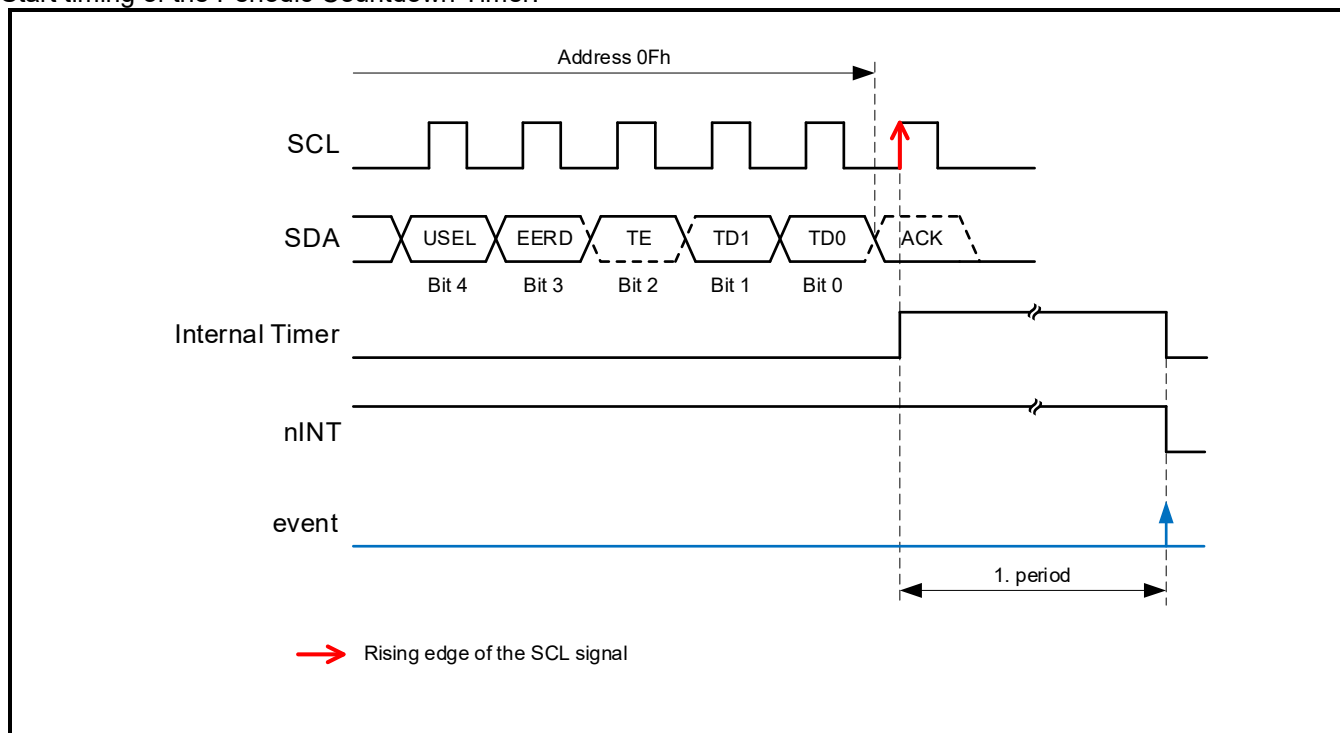


Figure 7-13 Periodic Countdown Timer Interrupt, countdown starting synchronization

7.9.3. FIRST PERIOD DURATION

When the TF flag is set, it indicates that an interrupt signal on nINT is generated if this mode is enabled. See Section [Interrupt Output](#) for details on how the interrupt can be controlled.

When starting the timer for the first time, the first period has an uncertainty. The uncertainty is a result of the enable instruction being generated from the interface clock which is asynchronous from the Timer Clock Frequency. Subsequent timer periods do not have such deviation. The amount of deviation for the first timer period depends on the chosen Timer Clock Frequency, see following Table.

First period duration for Timer Value n⁽¹⁾:

TD	Timer Clock Frequency	First period duration		Subsequent periods duration
		Minimum Period	Maximum Period	
00	4096 Hz	$n * 244 \mu\text{s}$	$(n + 1) * 244 \mu\text{s}$	$n * 244 \mu\text{s}$
01	64 Hz	$n * 15.625 \text{ ms}$	$(n + 1) * 15.625 \text{ ms}$	$n * 15.625 \text{ ms}$
10	1 Hz	$n * 1 \text{ s}$	$n * 1 \text{ s} + 15.625 \text{ ms}$	$n * 1 \text{ s}$
11	1/60 Hz	$n * 60 \text{ s}$	$n * 60 \text{ s} + 15.625 \text{ ms}$	$n * 60 \text{ s}$

(1) Timer Values n from 1 to 4095 are valid. Loading the counter with 0 stops the timer.

At the end of every countdown, the timer sets the Periodic Countdown Timer Flag (bit TF in Status Register). Bit TF can only be cleared by command. When enabled, a pulse is generated at the interrupt pin nINT.

When reading the Timer Value (Timer Value 0 and Timer Value 1), the preset value is returned and not the actual value. The actual value of the Periodic Countdown Timer can be read in the registers Timer Status 0 and Timer Status 1.

7.10. PERIODIC TIME UPDATE INTERRUPT FUNCTION

The Periodic Time Update Interrupt function generates an interrupt event periodically at the One-Second or the One-Minute update time, according to the selected timer source with bit USEL.

When an interrupt event is generated, the nINT pin goes to the low level and the UF flag is set to 1 to indicate that an event has occurred. The output on nINT pin is only effective if UIE bit in Control 2 register is set to 1. The low-level output signal on the nINT pin is automatically cleared after the Auto reset time t_{RTN2} . $t_{RTN2} = 500$ ms (Second update) or $t_{RTN2} = 7.813$ ms (Minute update).

When bit UIE is set to 1, the internal update interrupt pulse (UI) can be used to enable the clock output on FOUT pin automatically, when bits CUIE, CLKIE and CLKOE are set to 1 and a frequency is selected in the FD field (see **Clock Output Scheme**).

7.10.1. PERIODIC TIME UPDATE DIAGRAM

Diagram of the Periodic Time Update Interrupt function:

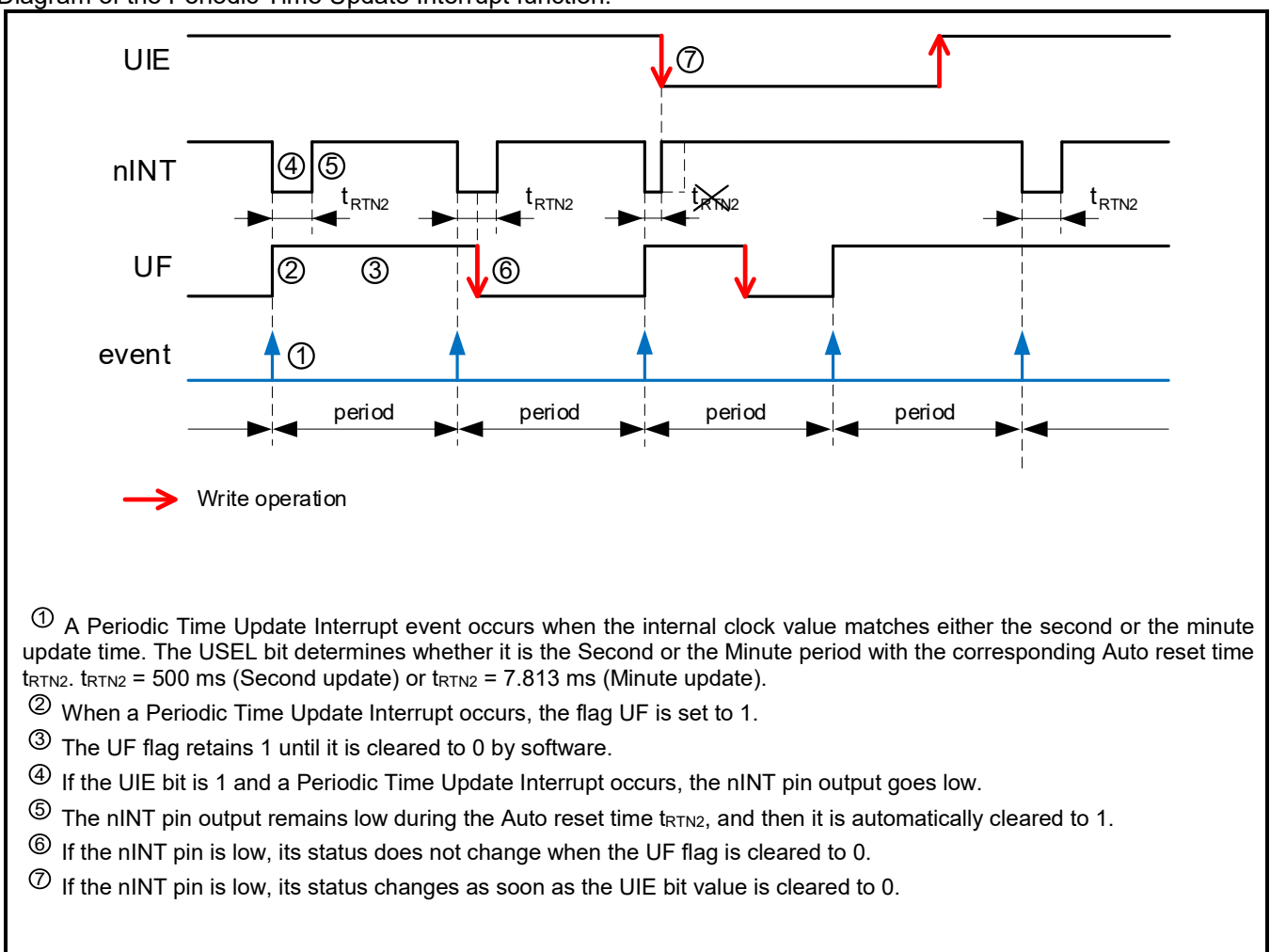


Figure 7-14 Periodic Time Update Interrupt

7.10.2. USE OF THE PERIODIC TIME UPDATE INTERRUPT

The following bits are related to the Periodic Time Update Interrupt and Automatic Clock output function:

- UF flag (see [Configuration Registers](#), 0Eh – Status)
- USEL bit (see [Configuration Registers](#), 0Fh – Control 1)
- UIE bit (see [Configuration Registers](#), 10h – Control 2)
- CUIE bit (see [Configuration Registers](#), 12h – Clock Interrupt Mask)

Prior to entering any other settings, it is recommended to write a 0 to the UIE bit to prevent inadvertent interrupts on nINT pin. The Periodic Time Update Interrupt function cannot be fully stopped, but by writing a 0 in the UIE bit, it prevents the occurrence of a hardware interrupt on the nINT pin.

When 1 is written to the RESET bit (see [Configuration Registers](#), 10h – Control 2) the divider chain is reset and the Periodic Time Update Interrupt will be retarded. The reset function only interrupts the Periodic Time Update Interrupt function but does not turn it off.

Procedure to use the Periodic Time Update Interrupt and Automatic Clock output function:

1. Initialize bits UIE and UF to 0.
2. Choose the timer source clock and write the corresponding value in the USEL bit.
3. Set the UIE bit to 1 if you want to get a hardware interrupt on nINT pin.
4. Set CUIE bit to 1 to enable clock output when a time update interrupt occurs. See also [Clock Output Scheme](#).
5. The first interrupt will occur after the next event, either second or minute change.

7.11. ALARM INTERRUPT FUNCTION

The Alarm Interrupt function generates an interrupt for alarm settings such as weekday/date, hour and minute settings.

When an interrupt event is generated, the nINT pin goes to the low level and the AF flag is set to 1 to indicate that an event has occurred. The output on the nINT pin is only effective if the AIE bit in the Control 2 register is set to 1.

When bit AIE is set to 1, the internal alarm interrupt signal (AI) can be used to enable the clock output on FOUT pin automatically, when bits CAIE, CLKIE and CLKOE are set to 1 and a frequency is selected in the FD field (see [Clock Output Scheme](#)).

7.11.1. ALARM DIAGRAM

Diagram of the Alarm Interrupt function:

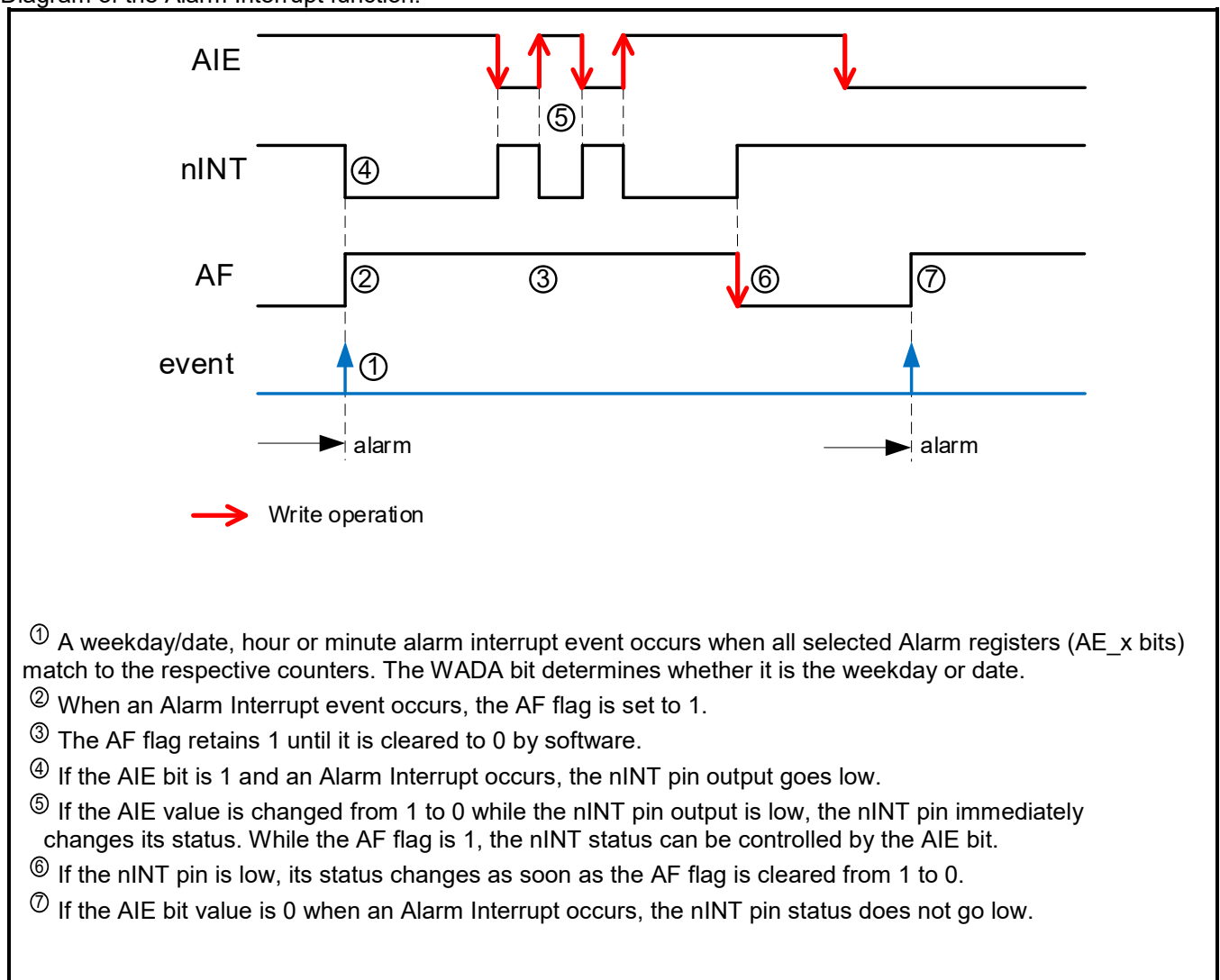


Figure 7-15 Alarm Interrupt

7.11.2. USE OF THE ALARM INTERRUPT

The following registers and bits are related to the Alarm Interrupt and Automatic Clock output function:

- Minutes Register (01h) (see [Clock Registers](#))
- Hours Register (02h) (see [Clock Registers](#))
- Weekday Register (03h) (see [Calendar Registers](#))
- Date Register (04h) (see [Calendar Registers](#))
- Minutes Alarm Register and AE_M bit (07h) (see [Alarm Registers](#))
- Hours Alarm Register and AE_H bit (08h) (see [Alarm Registers](#))
- Weekday/Date Alarm Register and AE_WD bit (09h) (see [Alarm Registers](#))
- AF flag (see [Configuration Registers](#), 0Eh – Status)
- WADA bit (see [Configuration Registers](#), 0Fh – Control 1)
- AIE bit (see [Configuration Registers](#), 10h – Control 2)
- CAIE bit (see [Configuration Registers](#), 12h – Clock Interrupt Mask)

Prior to entering any timer settings for the Alarm Interrupt, it is recommended to write a 0 to the AIE bit to prevent inadvertent interrupts on nINT pin. When 1 is written to the RESET bit, an Alarm Interrupt function event can be retarded. When the Alarm Interrupt function is not used, one Byte (07h) of the Alarm registers can be used as RAM byte. In such case, be sure to write a 0 to the AIE bit (if the AIE bit value is 1 and the Alarm register is used as RAM register, nINT may change to low level unintentionally).

Procedure to use the Alarm Interrupt and Automatic Clock output function:

1. Initialize bits AIE and AF to 0.
2. Choose weekday alarm or date alarm (weekday/date) by setting the WADA bit. WADA = 0 for weekday alarm or WADA = 1 for date alarm.
3. Write the desired alarm settings in registers 07h to 09h. The three alarm enable bits, AE_M, AE_H and AE_WD, are used to select the corresponding register that has to be taken into account for match or not. See the following table.
6. Set CAIE bit to 1 to enable clock output when an alarm occurs. See also [Clock Output Scheme](#).
4. Set the AIE bit to 1 if you want to get a hardware interrupt on nINT pin.

Alarm Interrupt:

Alarm enable bits			Alarm event
AE_WD	AE_H	AE_M	
0	0	0	When minutes, hours and weekday/date match (once per weekday/date)
0	0	1	When hours and weekday/date match (once per weekday/date)
0	1	0	When minutes and weekday/date match (once per hour per weekday/date)
0	1	1	When weekday/date match (once per weekday/date)
1	0	0	When hours and minutes match (once per day)
1	0	1	When hours match (once per day)
1	1	0	When minutes match (once per hour)
1	1	1	All disabled – Default value

AE_x bits (where x is WD, H or M)
 AE_x = 0: Alarm is enabled
 AE_x = 1: Alarm is disabled – Default value

7.12. EXTERNAL EVENT FUNCTION

The External Event Interrupt and the Time Stamp function are enabled by the control bits EIE, TSS and TSE. Depending of the EHL bit a high level (positive edge) or low level (negative edge) signal can be regarded as an event and furthermore a digital glitch filtering is applied to the EVI signal when selecting a sampling period in the ET field.

If enabled (EIE = 1, TSS = 0, TSE = 1 and EVF flag was cleared to 0 before) and an External Event on EVI pin is detected, the clock and calendar registers are captured and copied into the Time Stamp registers, the nINT is issued and the EVF flag is set to 1 to indicate that an external event has occurred.

When bit EIE is set to 1, the internal event interrupt signal (EI) can be used to enable the clock output on FOUT pin automatically, when bits CEIE, CLKIE and CLKOE are set to 1 and a frequency is selected in the FD field (see [Clock Output Scheme](#)).

Caution: The EVF flag is also set by an event of the Backup Switchover function when bits TSS and TSE are set to 1.

7.12.1. EXTERNAL EVENT DIAGRAM

Diagram of the External Event function. Example with positive edge/level detection (EHL = 1):

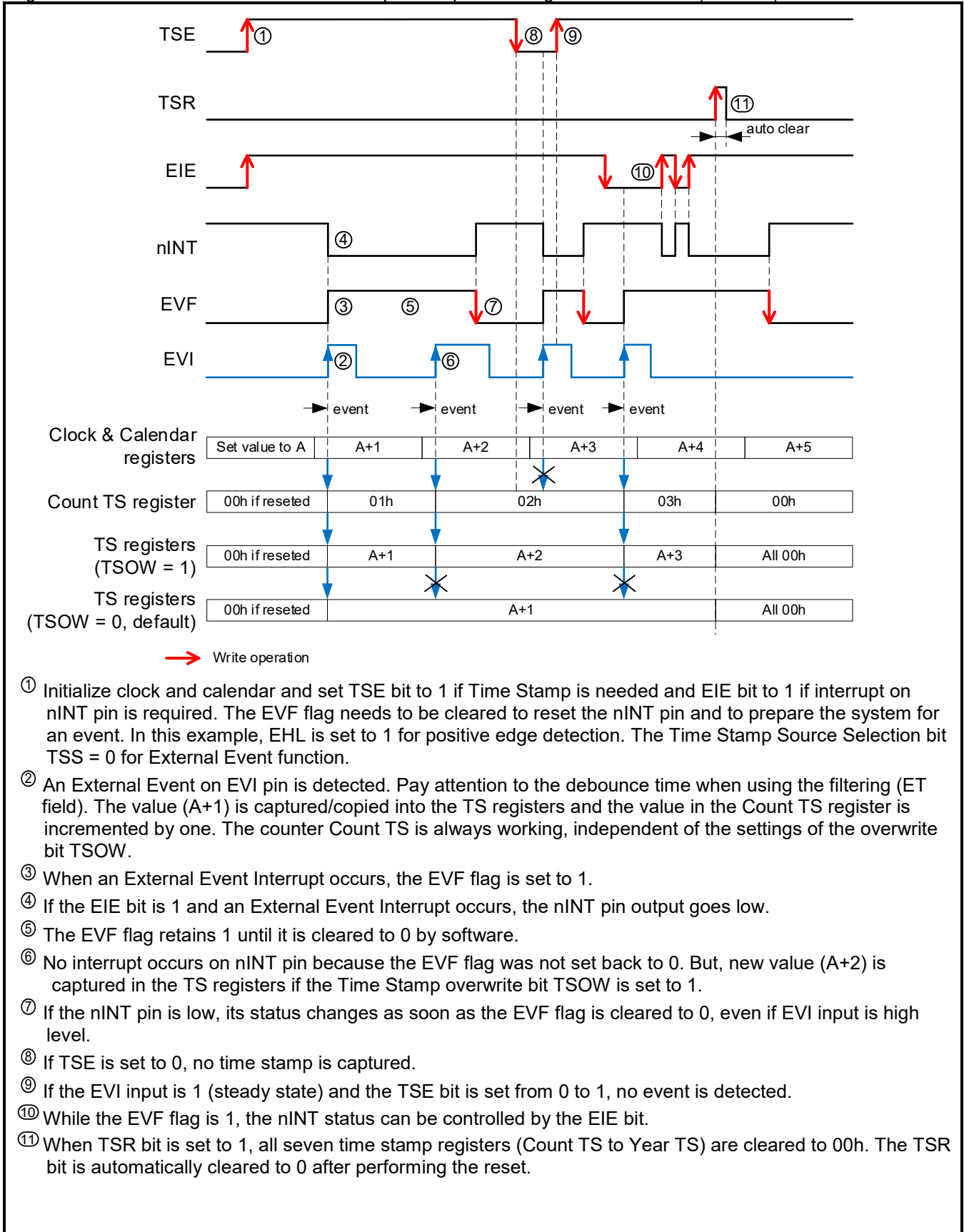


Figure 7-16 External Event

7.12.2. USE OF THE EXTERNAL EVENT FUNCTION

The following registers and bits are related to the External Event Interrupt, Time Stamp and Automatic Clock output function:

- Seconds Register (00h) (see [Clock Registers](#))
- Minutes Register (01h) (see [Clock Registers](#))
- Hours Register (02h) (see [Clock Registers](#))
- Date Register (04h) (see [Calendar Registers](#))
- Month Register (05h) (see [Calendar Registers](#))
- Year Register (06h) (see [Calendar Registers](#))
- Count TS Register (14h) (see [Time Stamp Registers](#))
- Seconds TS (15h) (see [Time Stamp Registers](#))
- Minutes TS (16h) (see [Time Stamp Registers](#))
- Hours TS (17h) (see [Time Stamp Registers](#))
- Date TS (18h) (see [Time Stamp Registers](#))
- Month TS (19h) (see [Time Stamp Registers](#))
- Year TS (1A) (see [Time Stamp Registers](#))
- EVF flag (see [Configuration Registers](#), 0Eh – Status)
- TSE and EIE bits (see [Configuration Registers](#), 10h – Control 2)
- CEIE bit (see [Configuration Registers](#), 12h – Clock Interrupt Mask)
- EHL bit, ET field, TSR bit, TSOW bit and TSS bit (see [Event Control Register](#))

Prior to entering any timer settings for the event interrupt, it is recommended to write a 0 to the EIE bit to prevent inadvertent interrupts on nINT pin.

Procedure to use the External Event Interrupt, Time Stamp and Automatic Clock output function:

1. Initialize bits TSE, EIE and flag EVF to 0.
2. Set TSR bit to 1, to reset all Time Stamp registers to 00h. After reset the TSR bit is automatically cleared.
3. Set EHL bit to 1 or 0 to choose high or low level detection on pin EVI.
4. Set ET field to apply filtering to the EVI pin. See following two diagrams.
5. Set TSS bit to 0 to select External Event on EVI pin as Time Stamp source.
6. Set TSOW bit to 1 if the last occurred event has to be recorded and TS registers are overwritten.
Hint: The counter Count TS is always working, independent of the settings of the overwrite bit TSOW.
7. Set CEIE bit to 1 to enable clock output when external event occurs. See also [Clock Output Scheme](#).
8. Set TSE bit to 1 if you want to enable the Time Stamp function.
9. Set EIE bit to 1 if you want to get a hardware interrupt on nINT pin.

Example with no filtering (ET = 00), with positive edge detection (EHL = 1) and enabled interrupt (EIE = 1):

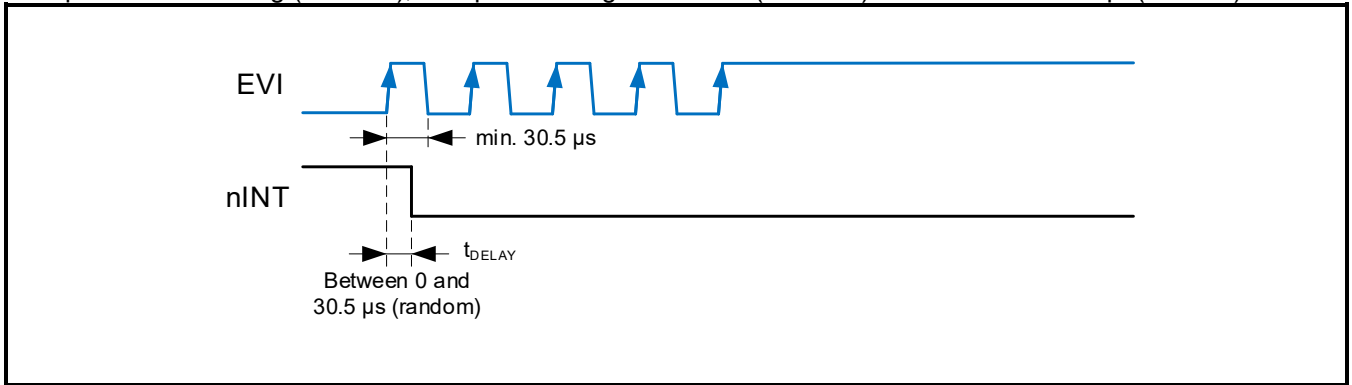


Figure 7-17 External Event function, No filtering example, EIE = 1

Example with digital debounce filtering (ET = 01, 10 or 11; sampling period $t_{SP} = 3.9 \text{ ms}$, 15.6 ms or 125 ms), with positive edge/level detection (EHL = 1) and enabled interrupt (EIE = 1):

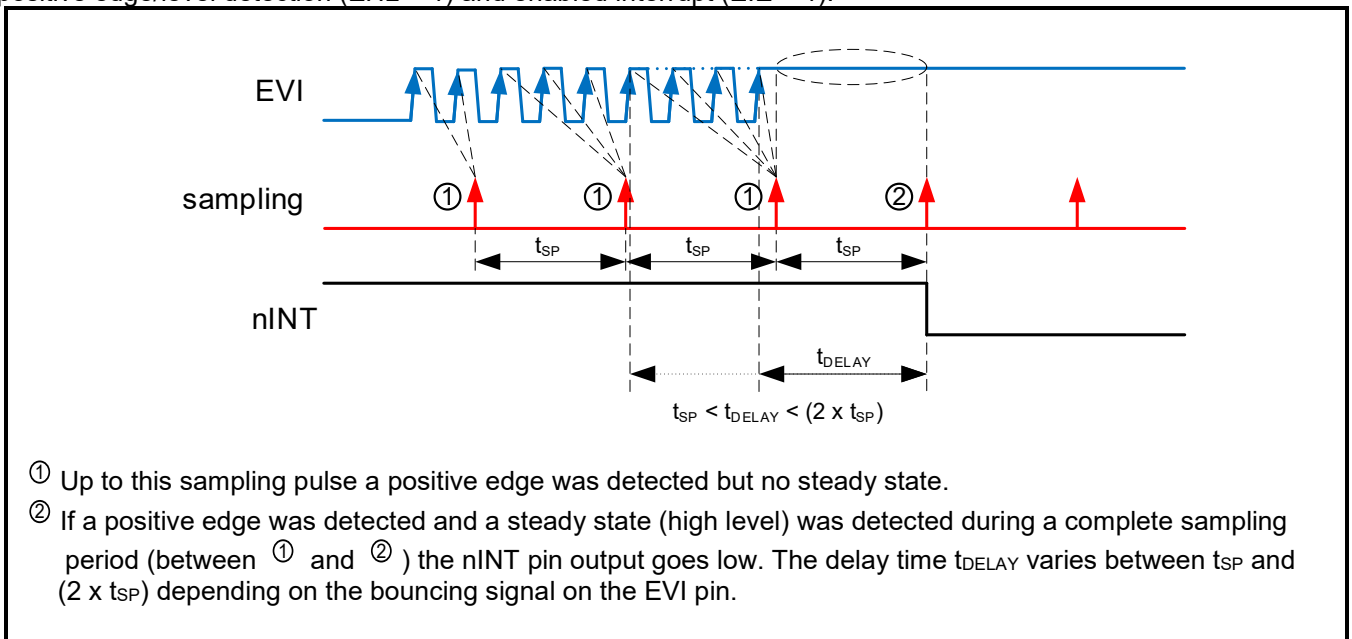


Figure 7-18 External Event function, with Filtering example, EIE = 1

7.13. AUTOMATIC BACKUP SWITCHOVER INTERRUPT FUNCTION

The Automatic Backup Switchover Interrupt function generates an interrupt event when the BSM field (EEPROM 37h) is set to 01 (DSM) or 11 (LSM) and a switchover from VDD Power state to VBACKUP Power state occurs.

When an interrupt event is generated, the nINT pin goes to the low level and the BSF flag is set to 1 to indicate that an event has occurred. The output on the nINT pin is only effective if the BSIE bit (EEPROM 37h) is set to 1.

When bit EIE is set to 1 and when the bits TSS and TSE are set to 1, the internal event interrupt signal (EI) created by the Automatic Backup Switchover function can be used to enable the clock output on FOUT pin automatically, when bits CEIE, CLKIE and CLKOE are set to 1 and a frequency is selected in the FD field. When again in VDD Power state, FOUT pin outputs the frequency (see [Clock Output Scheme](#)).

Hint: A debounce logic provides a 122 μ s – 183 μ s debounce time t_{DEB} , which will filter V_{DD} oscillation when the backup switchover will switch back from V_{BACKUP} to V_{DD} (see [AUTOMATIC BACKUP Switchover Function](#)).

Hint: The FEDE bit (EEPROM 37h) should always be set to 1, so that Fast Edge Detection (≥ 7 V/ms) is always enabled (see [EEPROM BACKUP Register](#)). – Default value on delivery

7.13.1. AUTOMATIC BACKUP SWITCHOVER DIAGRAM

Diagram of the Automatic Backup Switchover Interrupt function:

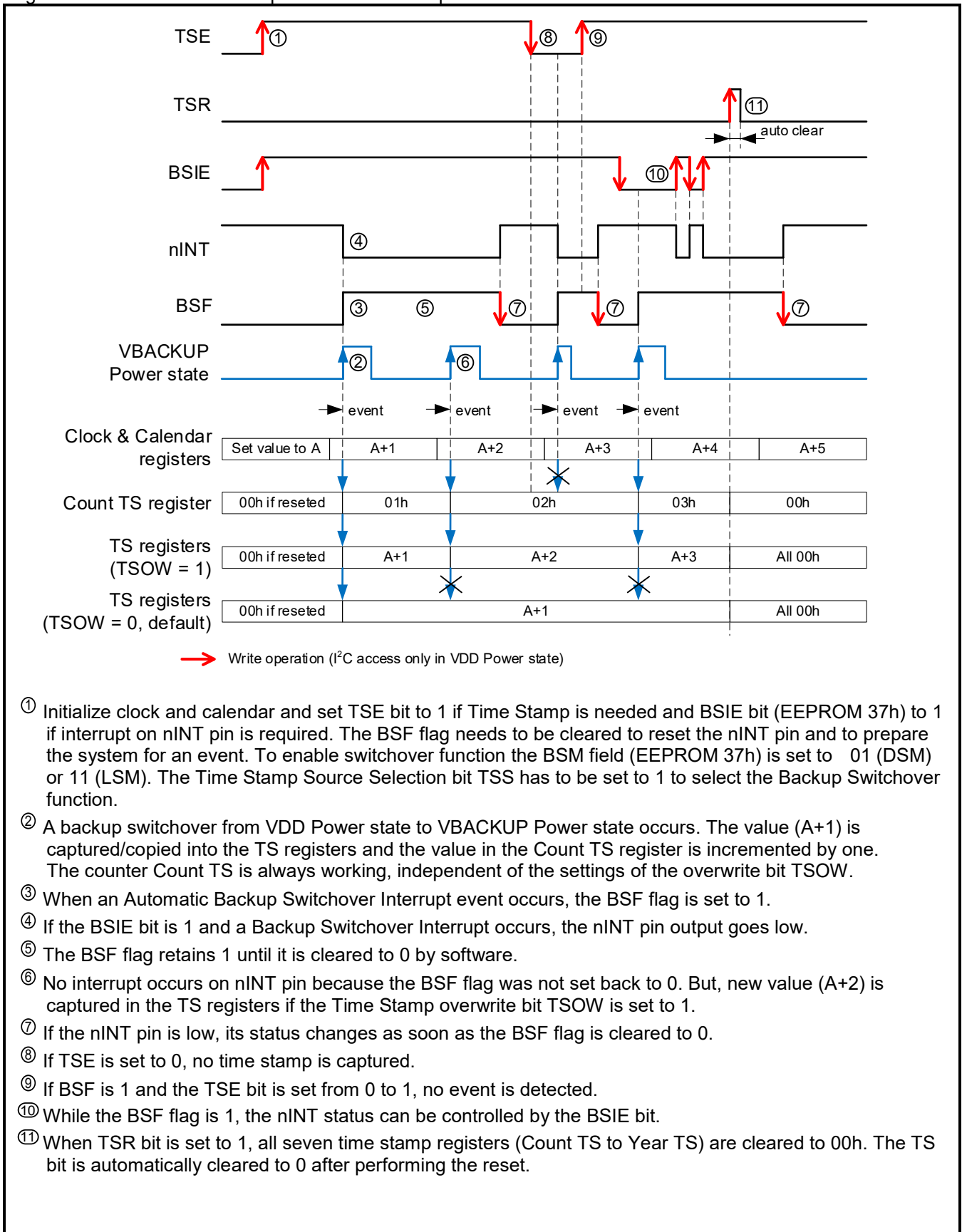


Figure 7-19 Automatic Backup Switchover

7.13.2. USE OF THE AUTOMATIC BACKUP SWITCHOVER INTERRUPT

The following registers and bits are related to the Automatic Backup Switchover Interrupt, Time Stamp and Automatic Clock output function:

- Seconds Register (00h) (see [Clock Registers](#))
- Minutes Register (01h) (see [Clock Registers](#))
- Hours Register (02h) (see [Clock Registers](#))
- Date Register (04h) (see [Calendar Registers](#))
- Month Register (05h) (see [Calendar Registers](#))
- Year Register (06h) (see [Calendar Registers](#))
- Count TS (14h) (see [Time Stamp Registers](#))
- Seconds TS (15h) (see [Time Stamp Registers](#))
- Minutes TS (16h) (see [Time Stamp Registers](#))
- Hours TS (17h) (see [Time Stamp Registers](#))
- Date TS (18h) (see [Time Stamp Registers](#))
- Month TS (19h) (see [Time Stamp Registers](#))
- Year TS (1A) (see [Time Stamp Registers](#))
- BSF flag (see [Configuration Registers](#), 0Eh – Status)
- CEIE bit (see [Configuration Registers](#), 12h – Clock Interrupt Mask)
- TSR bit, TSOW bit and TSS bit (see [Event Control Register](#))
- BSIE bit, FEDE bit and BSM field (see [EEPROM BACKUP Register](#))

Prior to entering any other settings, it is recommended to write a 0 to the BSIE bit to prevent inadvertent interrupts on nINT pin.

Procedure to use the Automatic Backup Switchover Interrupt, Time Stamp and Automatic Clock output function:

1. Initialize bits TSE, BSIE and BSF to 0.
2. Set TSR bit to 1, to reset all Time Stamp registers to 00h. After reset, the TSR bit is automatically cleared.
3. Set TSS bit to 1 to select Backup Switchover as Time Stamp source.
4. Set TSOW bit to 1 if the last occurred event has to be recorded and TS registers are overwritten.
Hint: The counter Count TS is always working, independent of the settings of the overwrite bit TSOW.
5. Set TSE bit to 1 if you want to enable the Time Stamp function.
6. Set CEIE bit to 1 to enable clock output when a backup switchover occurs.
Caution: This function is only working with the Automatic Backup Switchover function when the bits TSS and TSE are set to 1. See also [Clock Output Scheme](#).
7. The FEDE bit (EEPROM 37h) should always be set to 1, so that Fast Edge Detection (≥ 7 V/ms) is always enabled.
8. Set the BSIE bit to 1 (EEPROM 37h) if you want to get a hardware interrupt on nINT pin.
9. Choose the switchover mode (DSM or LSM) and write the corresponding value in the BSM field.

See also [EEPROM Read/Write Conditions](#).

7.14. POWER ON RESET INTERRUPT FUNCTION

The Power On Reset Interrupt function is enabled by the PORIE bit (EEPROM 35h). The PORIE bit has to be set beforehand in the EEPROM not in the RAM (see [EEPROM READ/WRITE](#)). When voltage drop below V_{POR} is detected ($V_{DD} < V_{POR}$) the PORF flag is set to 1 to indicate that a Power On Reset has occurred and when the PORIE bit is 1 the nINT pin goes to low level. A PORF value of 1 indicates also that the time information is corrupted. The value 1 is retained until a 0 is written by the user.

7.14.1. POWER ON RESET DIAGRAM

Diagram of the Power On Reset Interrupt function:

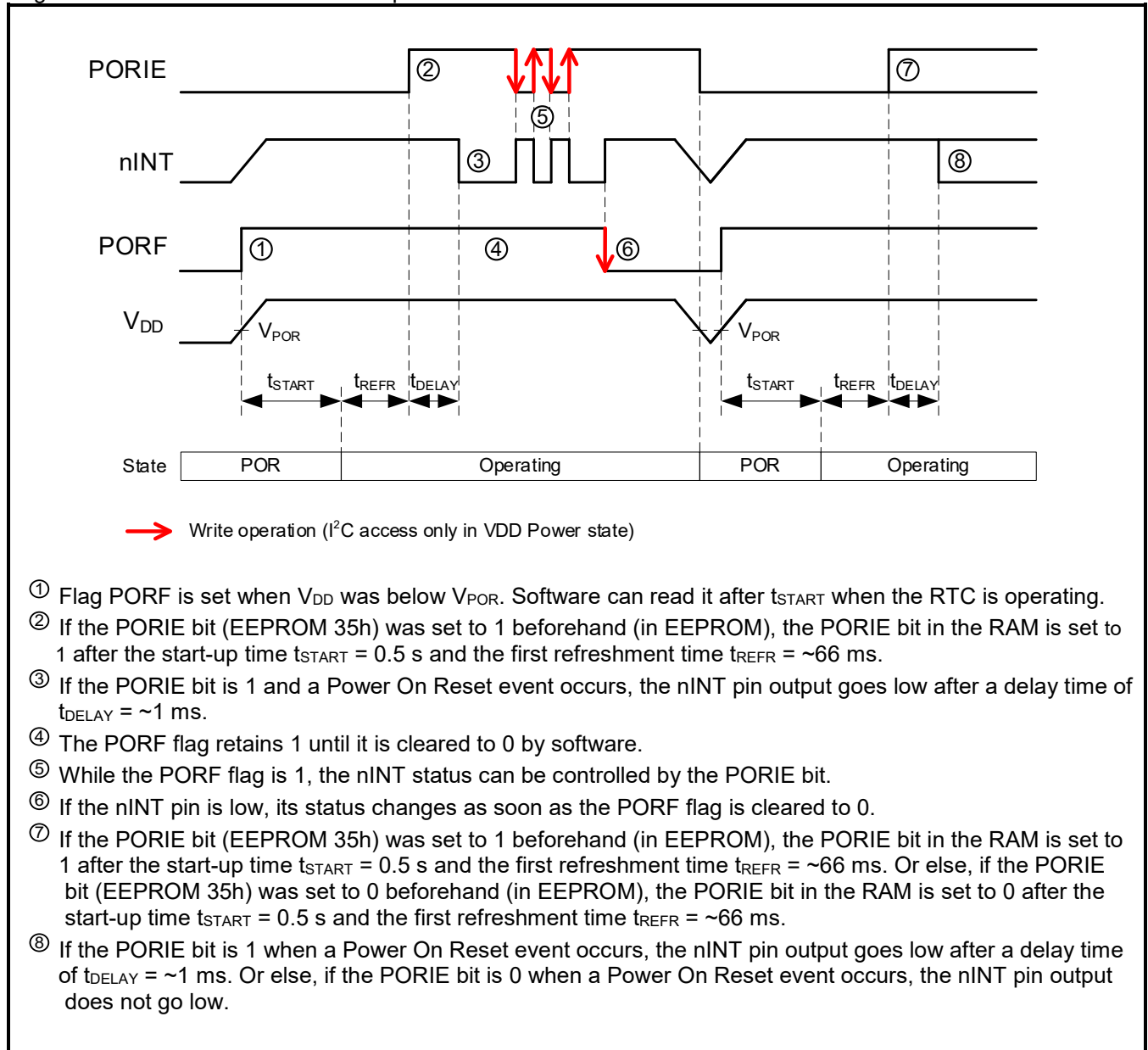


Figure 7-20 Power On Reset Interrupt

7.14.2. USE OF THE POWER ON RESET INTERRUPT

The following registers and bits are related to the Power On Reset Interrupt function (including EEPROM handling):

- PORF flag and EEbusy bit (see [Configuration Registers](#), 0Eh – Status)
- EERD bit (see [Configuration Registers](#), 0Fh – Control 1)
- EEaddr register (see [EEPROM Memory Control Registers](#), 25h –EEPROM Address)
- EEdata register (see [EEPROM Memory Control Registers](#), 26h –EEPROM Data)
- EEcmd register (see [EEPROM Memory Control Registers](#), 27h –EEPROM Commands)
- PORIE bit (see [EEPROM FOUT Register](#), 35h – EEPROM FOUT)

The PORIE bit has to be set beforehand in the EEPROM not in the RAM (see [EEPROM READ/WRITE](#)).

Procedure to use the Power On Reset Interrupt function:

1. In the EEPROM, set the PORIE bit to 1 if you want to get a hardware interrupt on nINT pin at the next Power On Reset event. Procedure according to [EEPROM READ/WRITE](#).
2. The first interrupt will occur after the next POR event.

7.15. TIME STAMP FUNCTION

The Time Stamp function is enabled by the control bit TSE. Sources are the External Event function (TSS = 0) or the Automatic Backup Switchover function (TSS = 1).

If a source is enabled and an event is detected, the Time Stamp (TS) registers are recorded. When the TSOW bit is set to 0 and the EVF flag was cleared to 0 before, only one (the first) event is recorded. When the TSOW bit is set to 1, the last event is recorded (EVF flag does not need to be cleared). The counter Count TS is always working, independent of the settings of the overwrite bit TSOW.

- When the TSR bit value is 1, the data of the time stamp in TS registers and Count TS are reset.
- Before writing settings for TS, it is recommended to write a 0 in the TSE bit and a 1 to EVR bit.
- When 1 is written to the RESET bit, the TS event can be retarded.

Procedures to use the Time Stamp function with the External Event Interrupt function or with the Automatic Backup Switchover function:

1. Write 0 in TSS and TSE bits. Select TSOW (0 or 1), clear EVF and BSF.
2. Write 1 in TSR bit then it is automatically cleared after performing the reset.
3. Write the desired external event or backup switchover settings (enabling function and interrupt on nINT pin):
 - a. See [External Event Function](#)
 - b. See [Automatic BACKUP Switchover Interrupt Function](#)
4. Set the TSE bit to 1 to enable the Time Stamp function.

Hint: The nINT signal is issued when EIE (RAM) or BSIE (EEPROM 37h) bit is set to 1. The EVF or BSF flag is set to 1 to indicate that a corresponding event has occurred.

Caution: Because the EVF flag is internally used for the identification of a First Event detection it is set by an event from the External Event function (TSS = 0, TSE = 1) or by an event of the Backup Switchover function (TSS = 1, TSE = 1). See also following scheme.

Complete Time Stamp scheme:

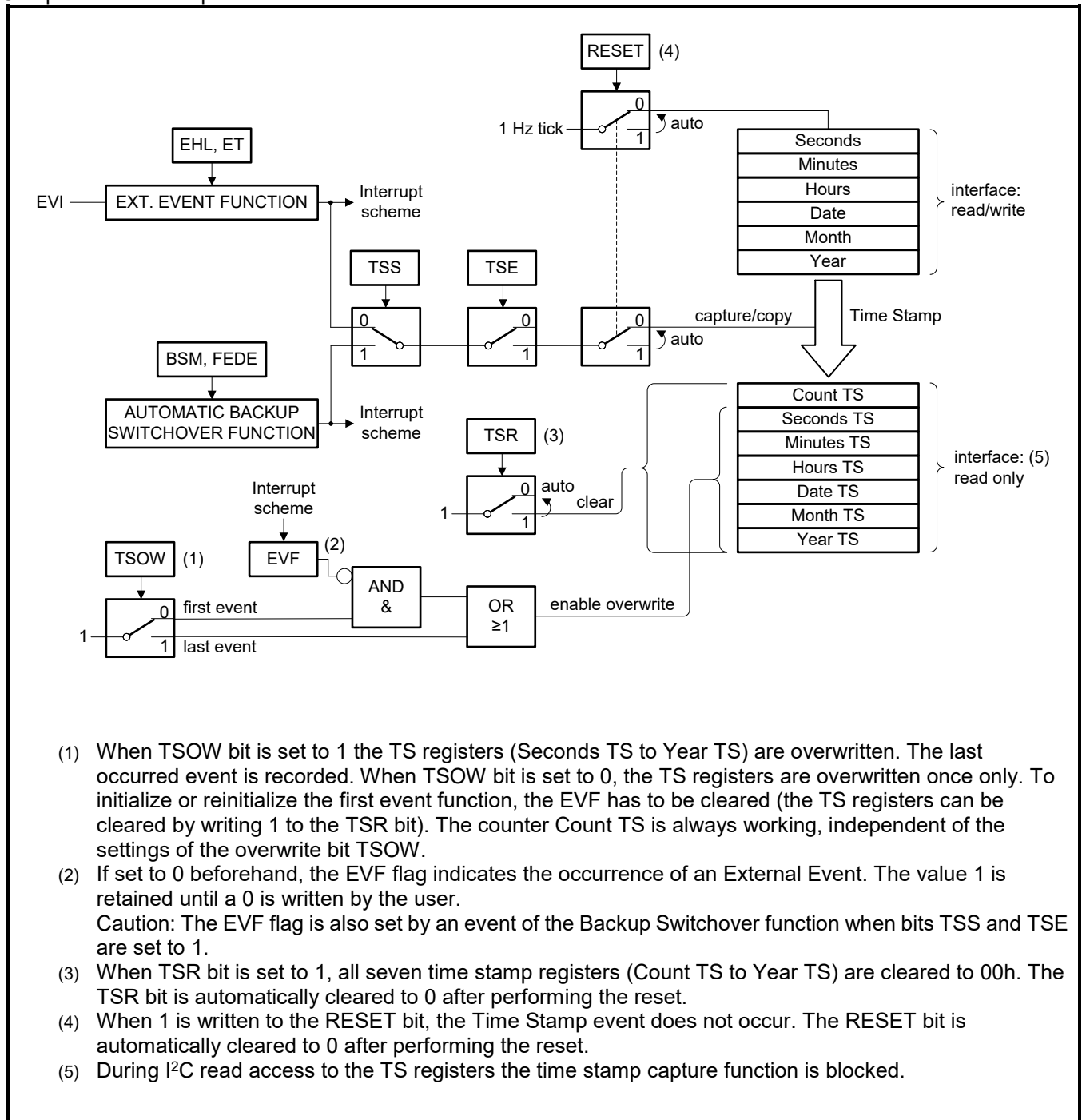


Figure 7-21 Time Stamp Scheme

- (1) When TSOW bit is set to 1 the TS registers (Seconds TS to Year TS) are overwritten. The last occurred event is recorded. When TSOW bit is set to 0, the TS registers are overwritten once only. To initialize or reinitialize the first event function, the EVF has to be cleared (the TS registers can be cleared by writing 1 to the TSR bit). The counter Count TS is always working, independent of the settings of the overwrite bit TSOW.
- (2) If set to 0 beforehand, the EVF flag indicates the occurrence of an External Event. The value 1 is retained until a 0 is written by the user.
Caution: The EVF flag is also set by an event of the Backup Switchover function when bits TSS and TSE are set to 1.
- (3) When TSR bit is set to 1, all seven time stamp registers (Count TS to Year TS) are cleared to 00h. The TSR bit is automatically cleared to 0 after performing the reset.
- (4) When 1 is written to the RESET bit, the Time Stamp event does not occur. The RESET bit is automatically cleared to 0 after performing the reset.
- (5) During I²C read access to the TS registers the time stamp capture function is blocked.

7.16. FREQUENCY OFFSET CORRECTION

An aging adjustment or accuracy tuning can be done with the EEOffset value. The correction is purely digitally and has only the effect of shifting the time vs. temperature curve vertically up or down. It has no effect on the time vs. temperature characteristics of the final frequency. The EEOffset value contains a two's complement number with a range of +255 to -256 adjustment steps. The minimal correction step (one LSB) is $\pm 1 / (32768 * 32) = \pm 0.9537$ ppm. The compensation period is 32 seconds. The maximum correction range is from +243.2 ppm to -244.1 ppm.

Note that the signed offset value EEOffset corresponds to the correction value of the measured frequency (32.768 kHz). The user has access to this field (see [EEPROM OFFSET Register](#)).

7.16.1. EEOFFSET VALUE DETERMINATION

The EEOffset value is determined by the following process:

1. Select the 32.768 kHz frequency on the FOUT pin.
(If another frequency than 32.768 kHz is selected, the EEOffset value has to be set to 0 so that the uncorrected frequency can be measured, and the following calculations have to be adapted.)
2. Measure the frequency Fmeas at FOUT pin in Hz.
3. Compute the offset value required in ppm: $POffset = ((Fmeas - 32768) / 32768 * 1'000'000)$
4. Compute the offset value in steps: $Offset = POffset / (1 / (32768 * 32) \text{ in ppm}) = POffset / (0.9537 \text{ ppm})$
5. If $Offset > 256$, the frequency is too high to be corrected.
6. Else if $1 \leq Offset \leq 256$ (correction is $-1 \geq OffsetCorr. \geq -256$), \rightarrow set $EEOffset = 512 - Offset$
7. Else if $-255 \leq Offset \leq 0$ (correction is $+255 \leq OffsetCorr. \leq 0$), \rightarrow set $EEOffset = - Offset$
8. Else the frequency is too low to be corrected.

Examples:

- If 32768.48 Hz is measured when the 32.768 kHz clock is selected, the offset is +0.48 Hz, which is $+0.48 \text{ Hz} / 32768 \text{ Hz} * 1'000'000 = +14.648$ ppm. The Offset value in steps is then calculated as follows: $+14.648 \text{ ppm} / 0.9537 \text{ ppm} = +15.36$, the rounded integral part is 15 (the offset correction is -15 steps). The unsigned EEOffset value is then: $512 - 15 = +497$. In binary, $EEOffset = 111110001$.
- If 32767.52 Hz is measured when the 32.768 kHz clock is selected, the offset is -0.48 Hz, which is $-0.48 \text{ Hz} / 32768 \text{ Hz} * 1'000'000 = -14.648$ ppm. The Offset value in steps is then calculated as follows: $-14.648 \text{ ppm} / 0.9537 \text{ ppm} = -15.36$, the rounded integral part is -15 (the offset correction is +15 steps). The EEOffset value is then: $-(-15) = +15$. In binary, $EEOffset = 000001111$.

7.16.2. VERIFICATION OF THE CORRECTED TIME ACCURACY

The offset correction can be verified by the following process:

1. Enter the calculated EEOffset value (see [EEOFFSET Value Determination](#)).
2. Select the 1 Hz frequency on the FOUT pin (if another frequency is selected the following calculations have to be adapted).
3. Measure every period during one compensation period of 32 seconds at FOUT pin.
4. Calculate the average frequency Fmeas_aver in Hz.
5. Compute the new achieved offset value in ppm: $POffset = ((Fmeas_aver - 1) / 1 * 1'000'000)$

7.17. UNIX TIME COUNTER

The UNIX Time counter is a 32-bit counter, unsigned integer, which rolls over to 00000000h when reaching the value FFFFFFFFh. The 4 bytes are fully readable and writable. The counter source clock is the digitally tuned 1 Hz clock frequency of the prescaler.

After writing the required time value into the UNIX Time registers, the write access can be synchronized by the RESET bit function. When 1 is written to the RESET bit in control 2 register, the associated I²C stop condition will synchronize the 1 Hz counter clock to the desired accurate time. The RESET bit is then automatically cleared. The first 1 Hz period after synchronization will be 0 to 244 μs shorter than 1 second. The 32-bit counter value itself is not changed at the moment when 1 is written to the RESET bit.

When reading the counter, the current value is returned. Since it is not possible to block the counter during read, it is recommended to read the four registers (UNIX Time 0 to UNIX Time 3) twice and to check for consistent results.

Write to UNIX Time counter and synchronization by using RESET bit:

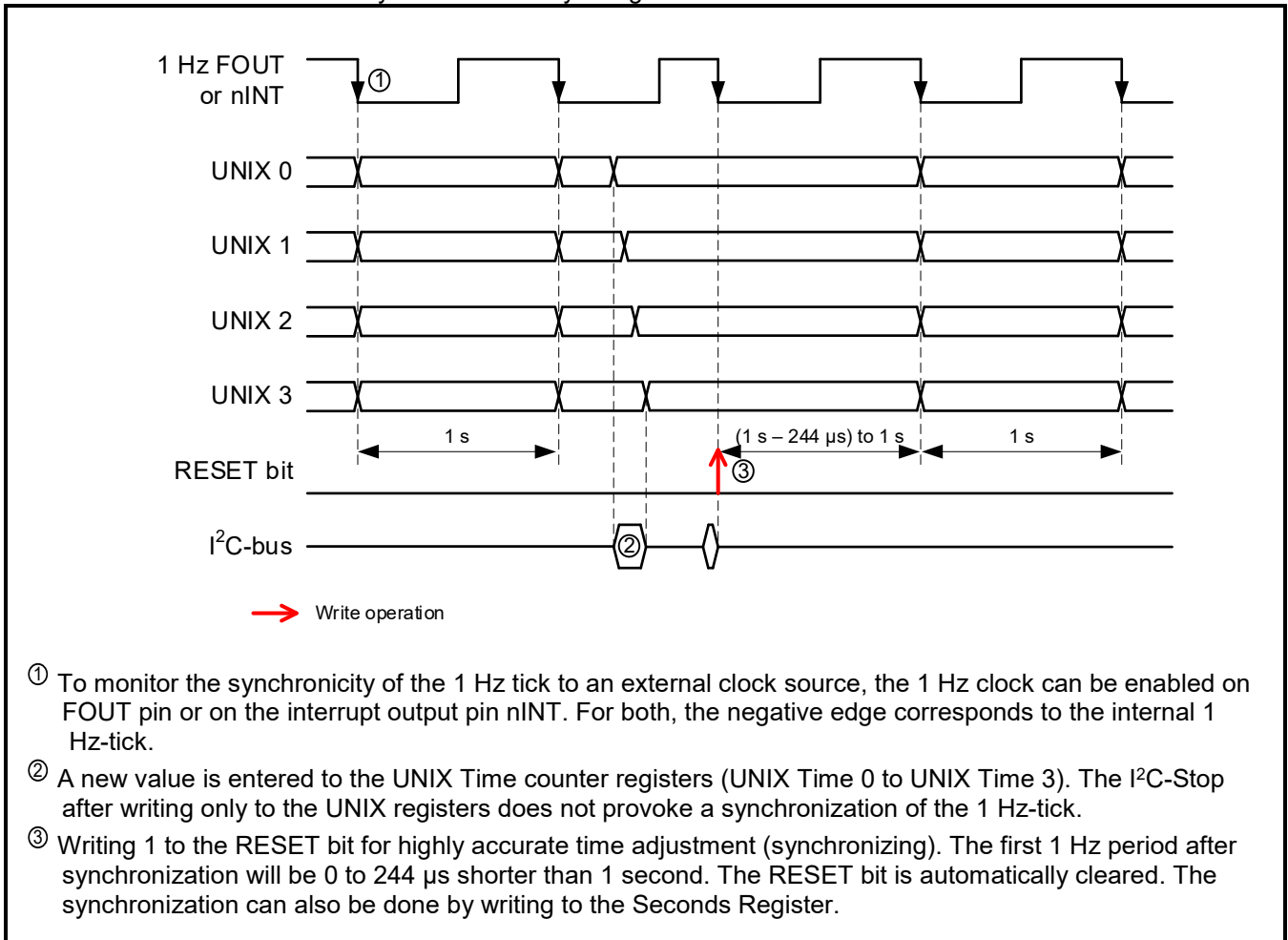


Figure 7-22 Unix Time Counter

7.18. RESET BIT FUNCTION

The RESET bit is used for a software-based accurate and safe starting of the time circuits.

When 1 is written to the RESET bit, the clock prescaler for 4096 Hz to 1Hz is reset and an eventual present memorized 1 Hz update is also reset. This bit is then automatically cleared. Because the upper two stages of the prescaler are not reset and the I²C interface is asynchronous, the next 1 Hz clock will be between (1 second – 244 μs) and 1 second. Resetting the prescaler will have an influence on the length of current clock period on all subsequent peripherals (clock and calendar, FOUT clock, timer clock, update timer clock, UNIX clock, EVI input filter).

The RESET bit function will not affect the FOUT of 32.768 kHz and 8192 Hz (see also **FOUT Frequency Selection**).

RESET bit functional diagram:

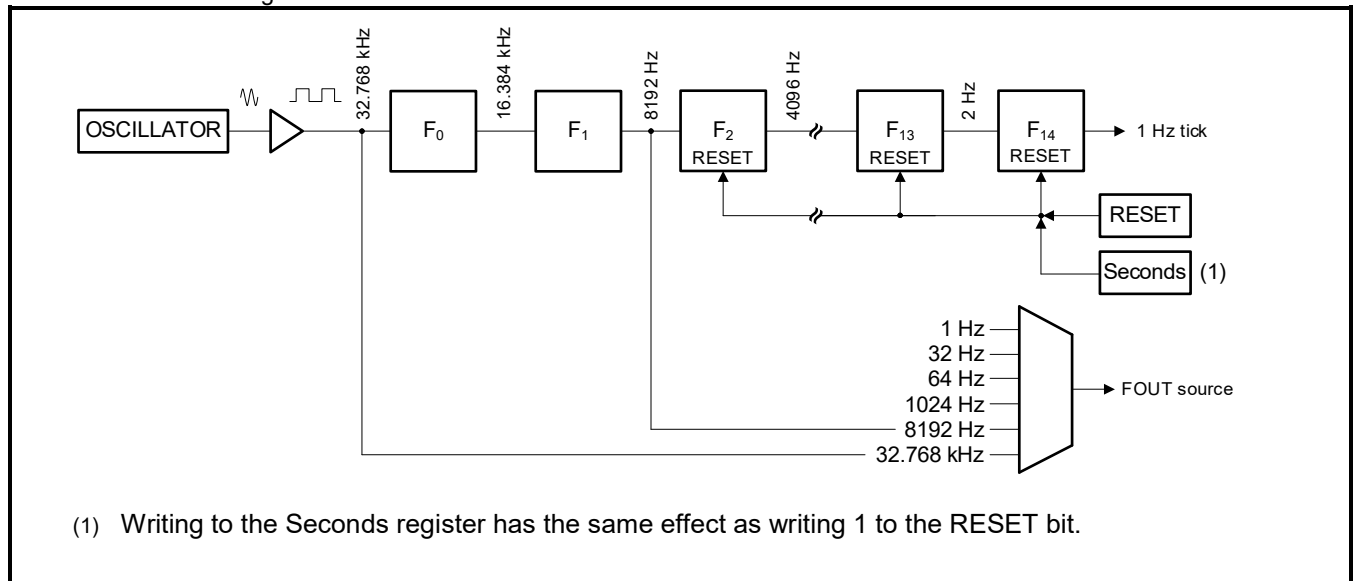


Figure 7-23 Reset bit Function

The clock and calendar can be set (in < 950 ms) and then synchronized by writing 1 to the RESET bit.

Setting the clock and calendar values using the RESET bit function:

1. Write the desired clock and calendar values to the registers (seconds, minutes, hours, weekday, date, month and year).
2. Write 1 to the RESET bit for a synchronized start of the time circuits (1 Hz tick). The RESET bit is automatically cleared.

7.19. USER PROGRAMMABLE PASSWORD

After a Power up and the first refreshment of ~66ms, the PW0 to PW3 registers are reset to 00h and the EEPWE (EEPROM 30h) and EEPW 0 to EEPW 3 values (EEPROM 31h to 34h) are copied from the EEPROM.

The first four Password registers (PW0 to PW3), in case of the use of the function (enabled by writing 255 into the EEPROM Password Enable register EEPWE), are used to write the 32-Bit Password necessary to be able to write in all writable registers (time and configuration registers). This 32-Bit Password is compared to the 32 bits stored in EEPROM Password registers EEPW 0 to EEPW 3 (see [PASSWORD Registers](#), [EEPROM Password Enable Register](#) and [EEPROM Password Registers](#)).

Caution: The number of possible passwords is $2^{32} \approx 4.3 * 10^9 = 4.3$ billion.

7.19.1. ENABLING/DISABLING WRITE PROTECTION

If the write protection function is enabled by writing 255 in register EEPWE (EEPROM 30h), it remains possible to read all the registers except the EEPROM registers. If the function is not enabled, read and write are possible for all corresponding registers.

If the write protection function is enabled, it is necessary to first write the 32-Bit Password before any attempt to write in the RAM registers, and to read and write in the EEPROM registers.

Once the user is finished with the write access and subsequently the write protection is enabled again (by writing 255 in EEPROM register EEPWE), it is necessary to write an incorrect password ($PW \neq EEPW$) into the Password registers PW0 to PW3 in order to write-protect the registers. See complete program sequences below and [Flowchart](#).

Enable write protection:

1. Registers are Not write-protected ($EEPWE \neq 255$)
2. Reference password is stored here (EEPW 0 to EEPW 3)
3. Disable automatic refresh ($EERD = 1$)
4. Enable password function ($EEPWE = 255$) (RAM)
5. Enter the correct password PW ($PW = EEPW$) to unlock write protection (PW0 to PW3)
6. Update EEPROM (all Configuration RAM \rightarrow EEPROM) with $EEcmd = 00h$ followed by 11h
7. Enable automatic refresh ($EERD = 0$)
8. Enter an incorrect password PW ($PW \neq EEPW$) to (PW0 to PW3) to lock the device
9. Registers are Write-protected by password ($EEPWE = 255$)

Disable write protection:

1. Registers are write protected by password ($EEPWE = 255$)
2. Reference password is stored here (EEPW 0 to EEPW 3)
3. Enter the correct password PW ($PW = EEPW$) to unlock write protection (PW0 to PW3)
4. Disable automatic refresh ($EERD = 1$)
5. Disable password function ($EEPWE \neq 255$) (RAM)
6. Update EEPROM (all Configuration RAM \rightarrow EEPROM) with $EEcmd = 00h$ followed by 11h
7. Enable automatic refresh ($EERD = 0$)
8. Registers are Not write-protected ($EEPWE \neq 255$)

7.19.2. CHANGING PASSWORD

To code a new password, the user has to first enter the current (correct) password into the Password registers (PW0 to PW3) if the registers are write protected, and writing a value not equal to all 1 (value \neq 255) in the EEPWE register (EEPROM 30h) to unlock write protection, and then write the new one in the registers EEPW 0 to EEPW 3 (EEPROM 31h to 34h) and writing all 1 (value = 255) in the EEPWE register to enable password function. See complete program sequences below and [Figure 7-24 User Programmable Password Flowchart](#).

Change password if password function is enabled (EEPWE = 255):

1. Registers are Write-protected by old password (EEPW 0 to EEPW 3)
2. Enter old password PW (PW = EEPW) to unlock write protection (PW0 to PW3)
3. Disable automatic refresh (EERD = 1)
4. Disable password function (EEPWE \neq 255)
5. Define a new password EEPW (EEPW 0 to EEPW 3) (RAM), and edit other configuration settings (RAM)
6. Enable the password function (EEPWE = 255) (RAM)
7. Enter correct password PW (PW = EEPW) to unlock write protection (PW0 to PW3)
8. Update EEPROM (all Configuration RAM \rightarrow EEPROM) with EEcmd = 00h followed by 11h
9. Enable automatic refresh (EERD = 0)
10. Enter an incorrect password PW (PW \neq EEPW) to (PW0 to PW3) to lock the device
11. Registers are Write-protected by new password (EEPW 0 to EEPW 3)

Change password if password function is disabled (EEPWE \neq 255):

1. Old password is stored here (EEPW 0 to EEPW 3)
2. Disable automatic refresh (EERD = 1)
3. Define a new password EEPW (EEPW 0 to EEPW 3) (RAM), and edit other configuration settings (RAM)
4. Update EEPROM (all Configuration RAM \rightarrow EEPROM) with EEcmd = 00h followed by 11h
5. Enable automatic refresh (EERD = 0)
6. New password is stored here (EEPW 0 to EEPW 3)

7.19.3. FLOWCHART

The following Flowchart describes the programming of the enabling and disabling of the register write protection by user password and the changing of the user password if write protection is enabled or disabled.

User programmable password for register write protection:

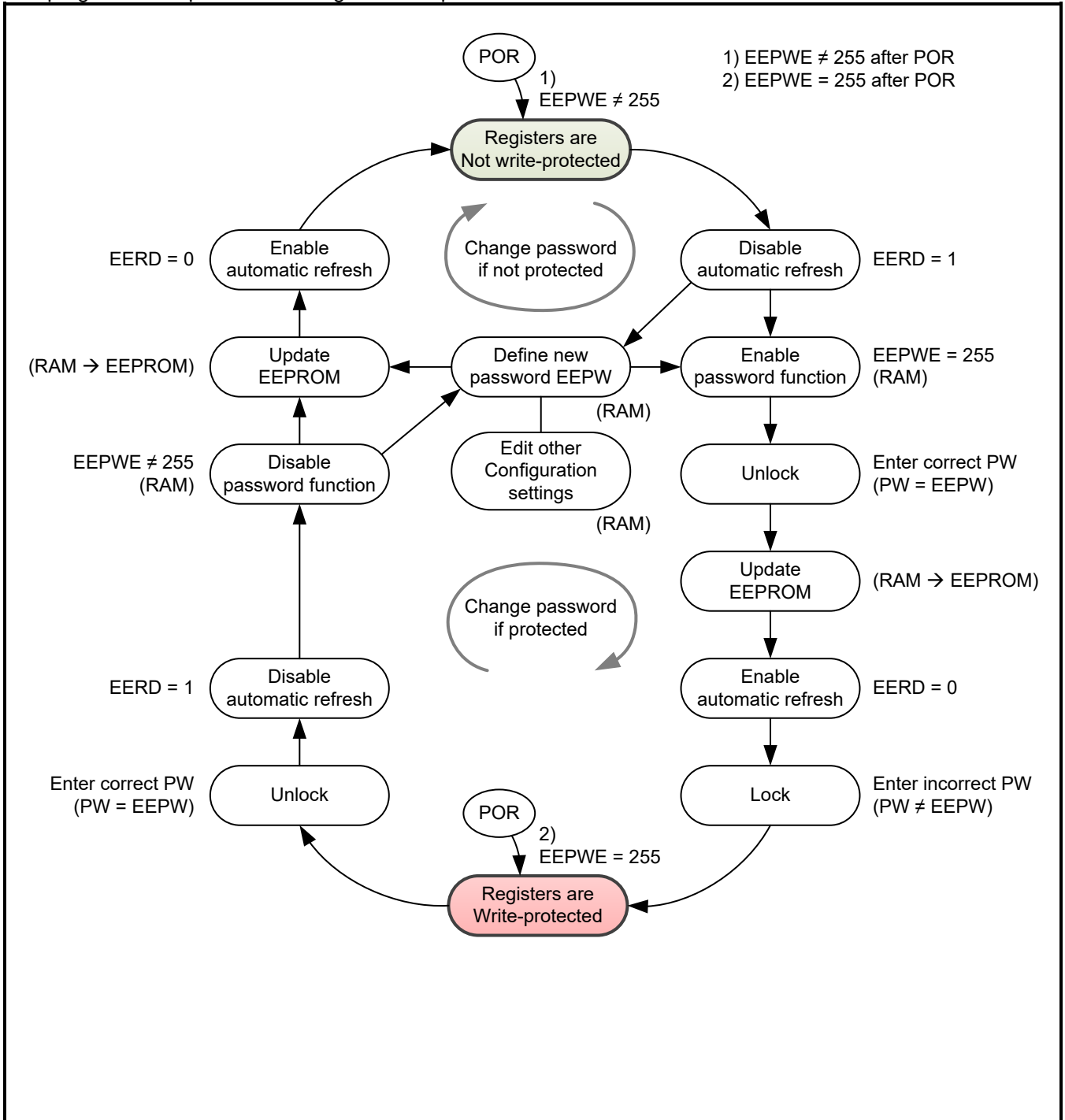


Figure 7-24 User Programmable Password Flowchart

7.20. I²C INTERFACE

The I²C interface is for bidirectional, two-line communication between different ICs or modules. The EM3028 is accessed at addresses A4h/A5h, and supports Fast Mode (up to 400 kHz). The I²C interface consists of two lines: one bi-directional data line (SDA) and one clock line (SCL). Both lines are connected to a positive supply via pull-up resistors. Data transfer is initiated only when the interface is not busy.

7.20.1. BIT TRANSFER

One data bit is transferred during each clock pulse. The data on the SDA line remains stable during the HIGH period of the clock pulse, as changes in the data line at this time are interpreted as a control signals. Data changes should be executed during the LOW period of the clock pulse (see **Figure 7-25 I²C Bit Transfer**).

Bit transfer:

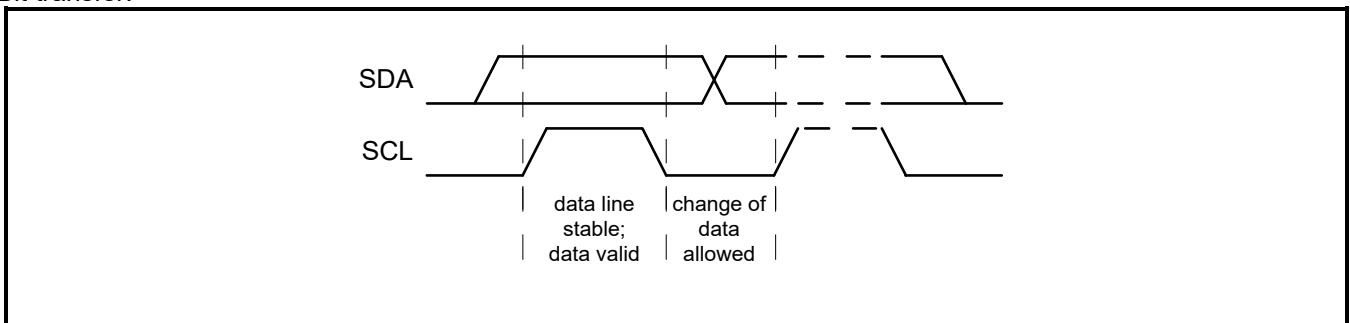


Figure 7-25 I²C Bit Transfer

7.20.2. START AND STOP CONDITIONS

Both data and clock lines remain HIGH when the bus is not busy. A HIGH-to-LOW transition of the data line, while the clock is HIGH, is defined as the START condition (S). A LOW-to-HIGH transition of the data line, while the clock is HIGH, is defined as the STOP condition (P) (see **Figure 7-26 I²C Start and Stop Conditions**).

Definition of START and STOP conditions:

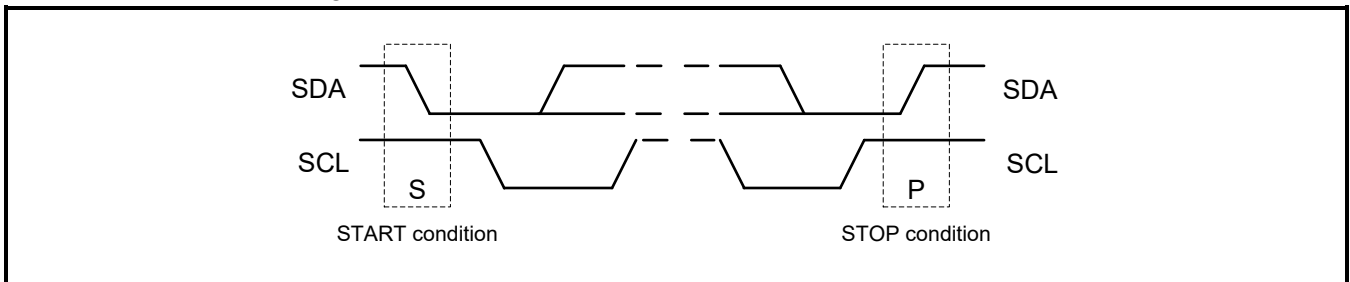


Figure 7-26 I²C Start and Stop Conditions

A START condition which occurs after a previous START but before a STOP is called a Repeated START condition, and functions exactly like a normal STOP followed by a normal START.

Caution:

When communicating with the EM3028, the series of operations from transmitting the START condition to transmitting the STOP condition should occur within **950 ms**.

If this series of operations requires **950 ms or longer**, the I²C bus interface will be automatically cleared and set to standby mode by the bus timeout function of the EM3028. Note with caution that both write and read operations are invalid for communications that occur during or after this auto clearing operation (when the read operation is invalid, all data that is read has a value of FFh).

Restarting of communications begins with transfer of the START condition again.

7.20.3. DATA VALID

After a START condition, SDA is stable for the duration of the high period of SCL. The data on SDA may be changed during the low period of SCL. There is one clock pulse per bit of data. Each data transfer is initiated with a START condition and terminated with a STOP condition. The number of data bytes transferred between the START and STOP conditions is not limited (however, the transfer time must be no longer than 950 ms). The information is transmitted byte-wide and each receiver acknowledges with a ninth bit.

7.20.4. SYSTEM CONFIGURATION

Since multiple devices can be connected with the I²C-bus, all I²C-bus devices have a fixed and unique device number built-in to allow individual addressing of each device.

The device that controls the I²C-bus is the Master; the devices which are controlled by the Master are the Slaves. A device generating a message is a Transmitter; a device receiving a message is the Receiver. The EM3028 acts as a Slave-Receiver or Slave-Transmitter.

Before any data is transmitted on the I²C-bus, the device which should respond is addressed first. The addressing is always carried out with the first byte transmitted after the START procedure. The clock signal SCL is only an input signal, but the data signal SDA is a bidirectional line.

System configuration:

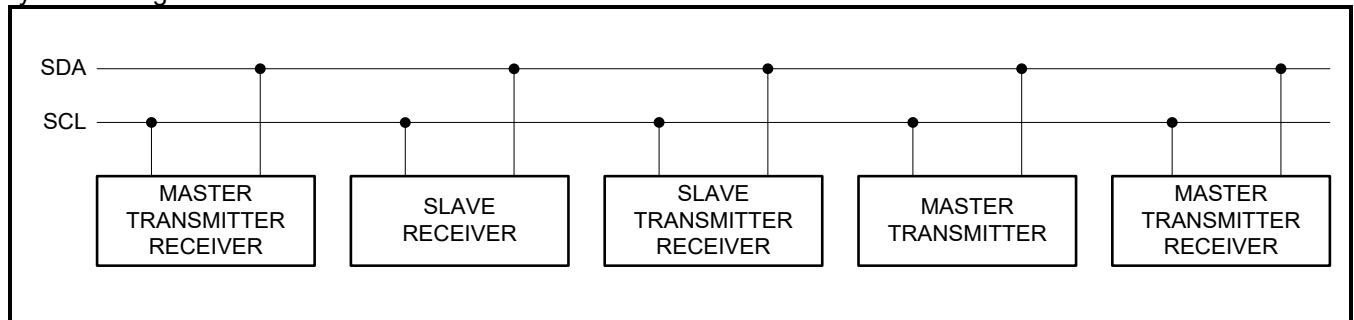


Figure 7-27 I²C System Configuration

7.20.5. ACKNOWLEDGE

The number of data bytes transferred between the START and STOP conditions from transmitter to receiver is unlimited (however, the transfer time must be no longer than 950 ms). Each byte of eight bits is followed by an acknowledge cycle.

- A slave receiver, which is addressed, must generate an acknowledge cycle after the reception of each byte.
- Also a master receiver must generate an acknowledge cycle after the reception of each byte that has been clocked out of the slave transmitter.
- The device that acknowledges must pull-down the SDA line during the acknowledge clock pulse, so that the SDA line is stable LOW during the HIGH period of the acknowledge-related clock pulse (set-up and hold times must be taken into consideration).
- A master receiver must signal an end of data to the transmitter by not generating an acknowledge cycle on the last byte that has been clocked out of the slave. In this event the transmitter must leave the data line HIGH to enable the master to generate a STOP condition.

Data transfer and acknowledge on the I²C-bus:

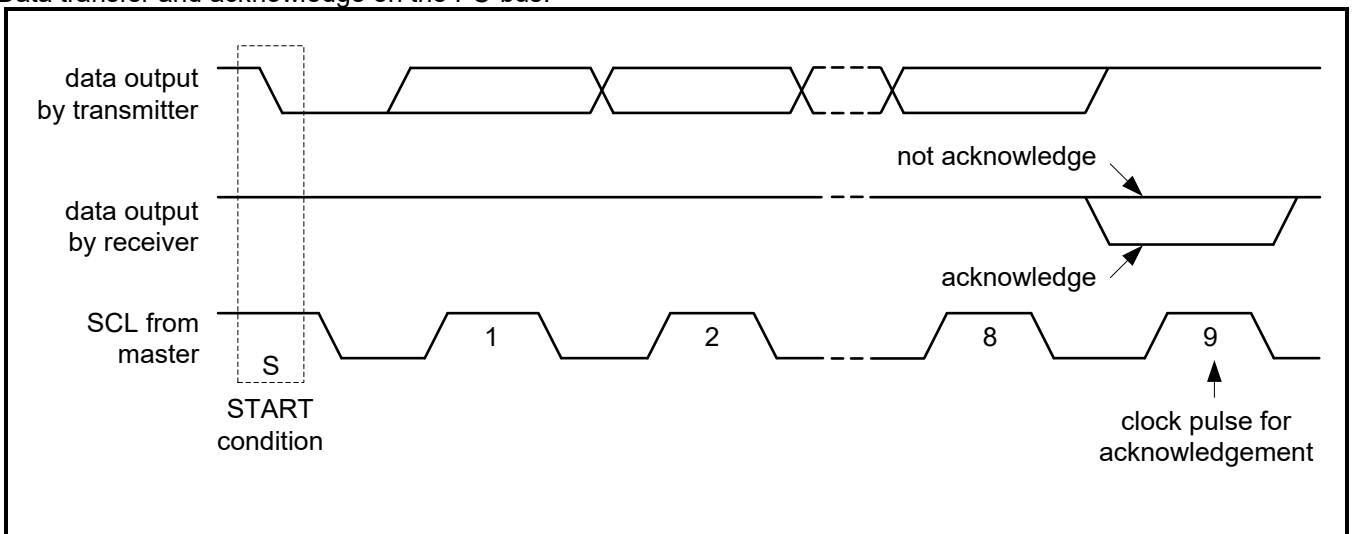


Figure 7-28 I²C Acknowledge

7.20.6. SLAVE ADDRESS

On the I²C-bus the 7-bit slave address 1010010b is reserved for the EM3028. The entire I²C-bus slave address byte is shown in the following table.

Slave address							R/W	Transfer data
Bit 7	Bit 6	Bit 5	Bit 4	Bit 3	Bit 2	Bit 1	Bit 0	
1	0	1	0	0	1	0	1 (R)	A5h (read)
							0 (\overline{W})	A4h (write)

After a START condition, the I²C slave address has to be sent to the EM3028 device. The $\overline{R/\overline{W}}$ bit defines the direction of the following single or multiple byte data transfer. The 7-bit address is transmitted MSB first. If this address is 1010010b, the EM3028 is selected, the eighth bit indicates a read ($\overline{R/\overline{W}} = 1$) or a write ($\overline{R/\overline{W}} = 0$) operation (results in A5h or A4h) and the EM3028 supplies the ACK. The EM3028 ignores all other address values and does not respond with an ACK.

In the write operation, a data transfer is terminated by sending either the STOP condition or the START condition of the next data transfer.

7.20.7. WRITE OPERATION

Master transmits to Slave-Receiver at specified address. The Register Address is an 8-bit value that defines which register is to be accessed next. After writing one byte, the Register Address is automatically incremented by 1.

Master writes to slave EM3028 at specific address:

- 1) Master sends out the START condition.
- 2) Master sends out Slave Address, A4h for the EM3028; the $\overline{R/\overline{W}}$ bit is a 0 indicating a write operation.
- 3) Acknowledgement from EM3028.
- 4) Master sends out the Register Address to EM3028.
- 5) Acknowledgement from EM3028.
- 6) Master sends out the Data to write to the specified address in step 4).
- 7) Acknowledgement from EM3028.
- 8) Steps 6) and 7) can be repeated if necessary. The address is automatically incremented in the EM3028.
- 9) Master sends out the STOP Condition.

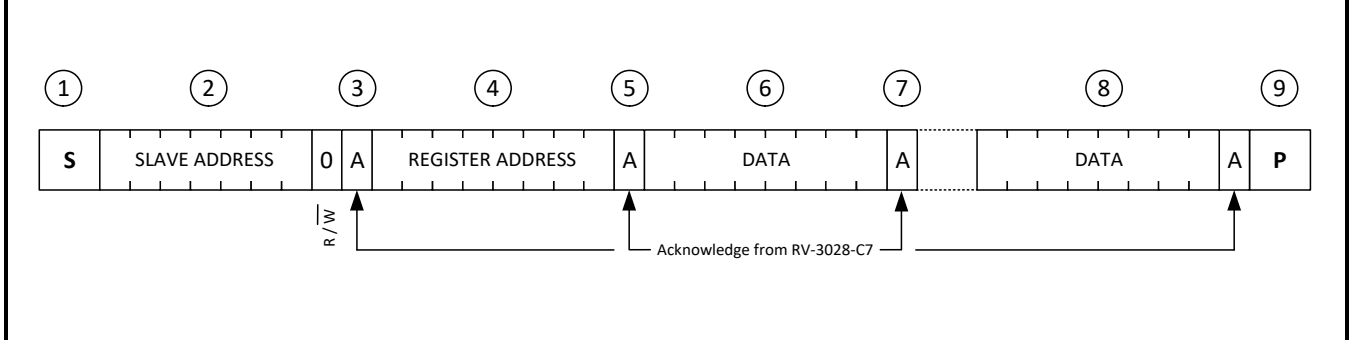


Figure 7-29 I²C Write Operation

7.20.8. READ OPERATION AT SPECIFIC ADDRESS

Master reads data from slave EM3028 at specific address:

- 1) Master sends out the START condition.
- 2) Master sends out Slave Address, A4h for the EM3028; the R/W bit is a 0 indicating a write operation.
- 3) Acknowledgement from EM3028.
- 4) Master sends out the Register Address to EM3028.
- 5) Acknowledgement from EM3028.
- 6) Master sends out the Repeated START condition (or STOP condition followed by START condition)
- 7) Master sends out Slave Address, A5h for the EM3028; the R/W bit is a 1 indicating a read operation.
- 8) Acknowledgement from EM3028.
- At this point, the Master becomes a Receiver and the Slave becomes the Transmitter.
- 9) The Slave sends out the Data from the Register Address specified in step 4).
- 10) Acknowledgement from Master.
- 11) Steps 9) and 10) can be repeated if necessary. The address is automatically incremented in the EM3028.
- 12) The Master, addressed as Receiver, can stop data transmission by not generating an acknowledge on the last byte that has been sent from the Slave-Transmitter. In this event, the Slave-Transmitter must leave the data line HIGH to enable the Master to generate a STOP condition.
- 13) Master sends out the STOP condition.

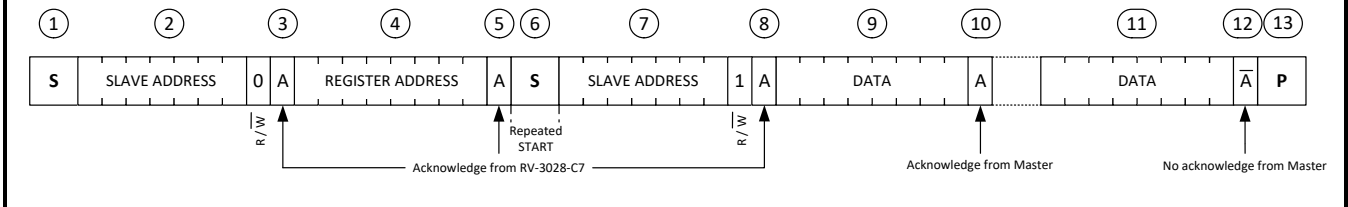


Figure 7-30 I²C Master reads data from slave EM3028 at specific address

7.20.9. READ OPERATION

Master reads data from slave EM3028 immediately after first byte:

- 1) Master sends out the START condition.
- 2) Master sends out Slave Address, A5h for the EM3028; the R/W bit is a 1 indicating a read operation.
- 3) Acknowledgement from EM3028.
- At this point, the Master becomes a Receiver and the Slave becomes the Transmitter.
- 4) The EM3028 sends out the Data from the last accessed Register Address incremented by 1.
- 5) Acknowledgement from Master.
- 6) Steps 4) and 5) can be repeated if necessary. The address is automatically incremented in the EM3028.
- 7) The Master, addressed as Receiver, can stop data transmission by not generating an acknowledge on the last byte that has been sent from the Slave-Transmitter. In this event, the Slave-Transmitter must leave the data line HIGH to enable the Master to generate a STOP condition.
- 8) Master sends out the STOP condition.

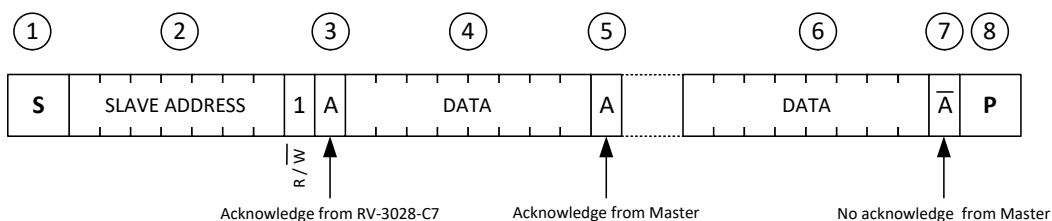


Figure 7-31 I²C Master reads data from slave EM3028 immediately after first byte

7.20.10. I²C-BUS IN SWITCHOVER CONDITION

To save power when the EM3028 is in VBACKUP Power state the bus I²C-bus interface is automatically disabled (high impedance) and reset. Therefore the communication via I²C interface should be terminated before the supply is switched from V_{DD} to V_{BACKUP}. When the bus communication is not terminated in a proper way, the time counters get corrupted.

If the I²C communication was terminated uncontrolled, the I²C has to be reinitialized by sending a STOP followed by a START after the device switched back from VBACKUP Power state to V_{DD} Power state.

8. TYPICAL APPLICATION

8.1. OPERATING EM3028 WITH BACKUP SUPPLY VOLTAGE

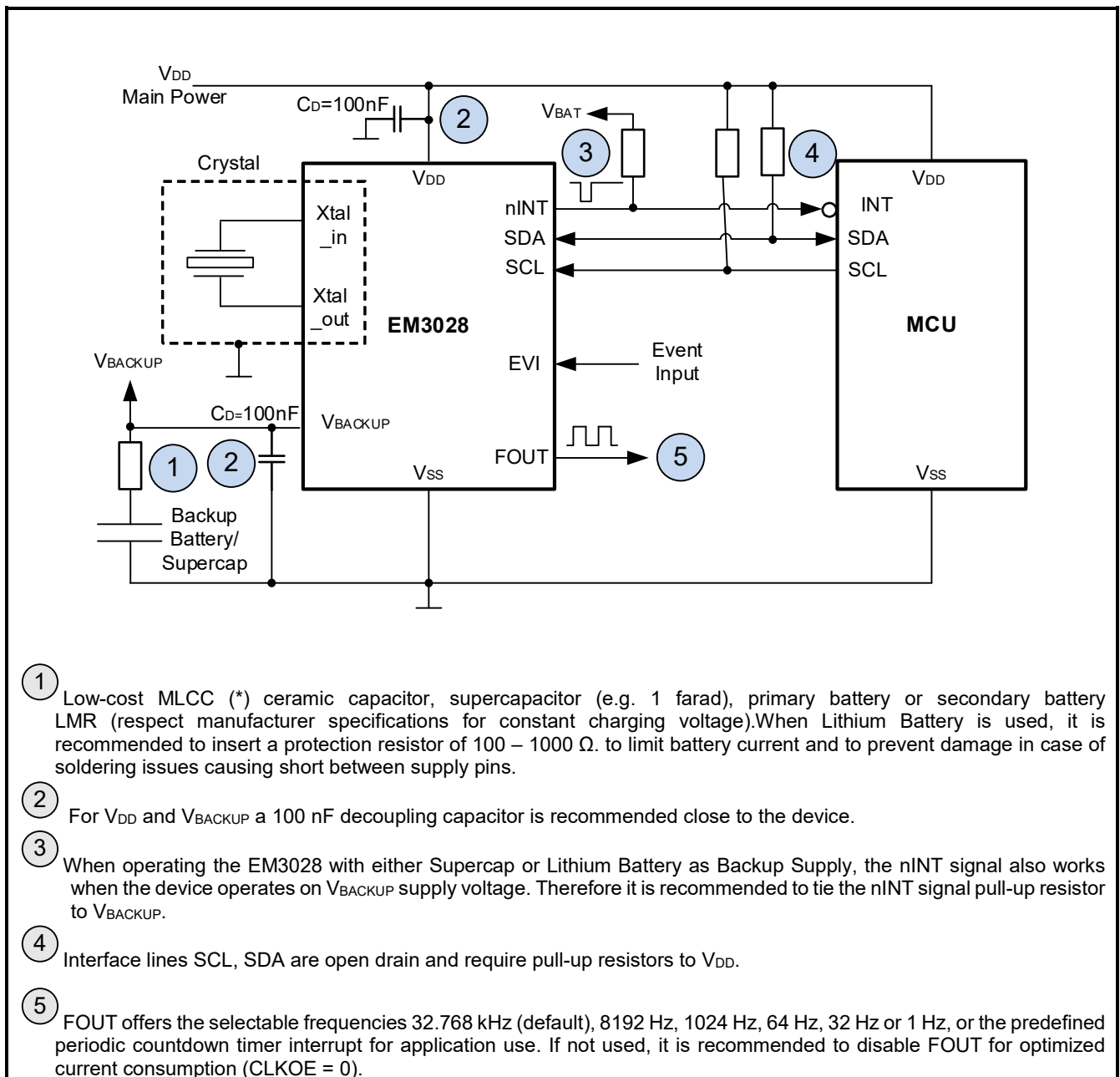


Figure 8-1 Example of Application

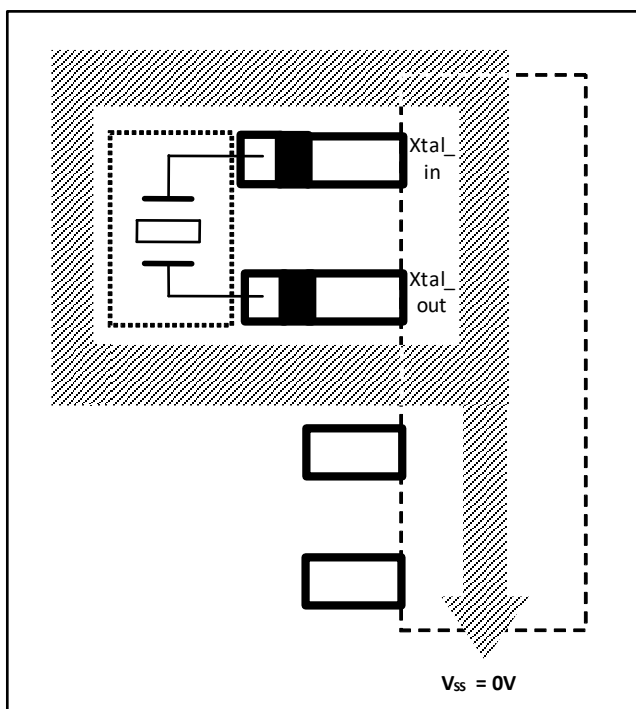
Component	Symbol	Value
CM7V-T1A	Crystal	32768Hz
Super capacitor	C _{BACKUP}	1 F
Decoupling capacitor	C _D	100 nF
Pullup resistor	R _{PULLUP}	10kΩ

Table 64 Component list

8.2. CRYSTAL LAYOUT GUIDELINE

Since the crystal inputs have very high impedance and the EM3028 is Extreme Low Power, only 40nA, the leads to the crystal act like very good antenna, coupling high-frequency signals from the rest of the system. If a signal is coupled onto the crystal pins, it can either cancel out or add pulses. Since most of the signals on a board are at a much higher frequency than the 32.768 kHz crystal, it is more likely to add pulses where none are wanted. The following measures are essential for optimizing the configuration:

- It is important to place the EM3028 and crystal as close as possible to the Xtal_in and Xtal_out pins. Keeping the trace lengths between the crystal and RTC as small as possible reduces the probability of noise coupling by reducing the length of the antenna. Keeping the trace lengths small also decreases the amount of stray capacitance.
- Place a guard ring (connected to ground) around the crystal. This helps isolate the crystal from noise coupled from adjacent signals.
- Do not place any signal as FOUT, EVI, nINT, SCL, SDA or power lines close to the crystal oscillation circuit and Xtal_in, Xtal_out pin
- Ensure that no signals on other PCB layers run directly below the crystal or below the traces to the Xtal_in and Xtal_out pins. The more the crystal is isolated from other signals on the board, the less likely it is that noise is coupled into the crystal.



9. ORDERING INFORMATION

Part Nb	Package form	Delivery form
EM3028V3TP14B	TSSOP14	Tape & Reel

Table 65 Ordering Information

For other delivery formats please contact EM Microelectronics representative.

10. PACKAGING INFORMATION

10.1. 14LD TSSOP (REV C)

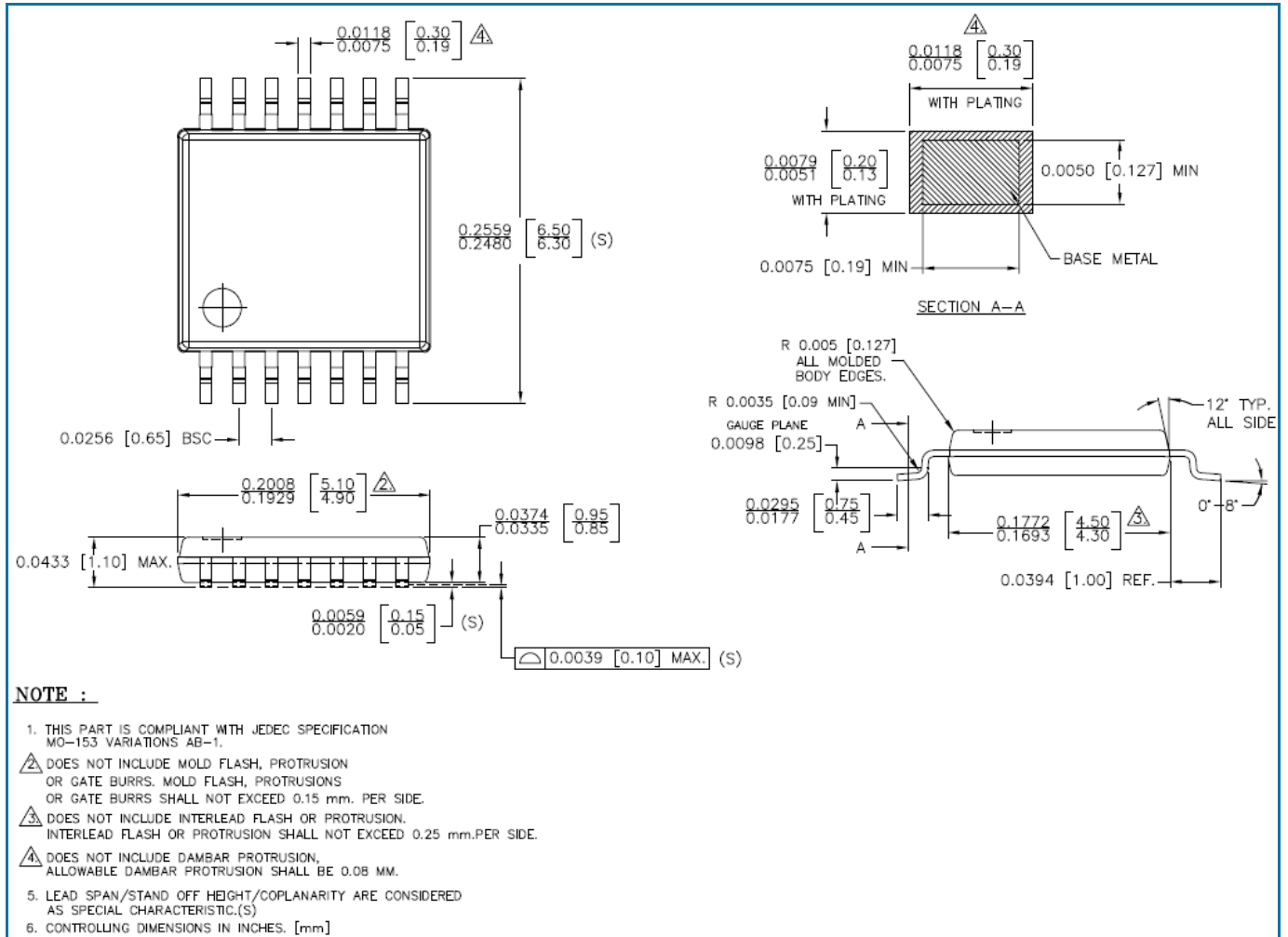


Figure 10-1 14LD TSSOP Package Outline Drawing

10.2. TAPE & REEL INFORMATION

Reel: 13" = 330 mm

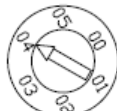


ATTENTION
OBSERVE PRECAUTIONS
FOR HANDLING
ELECTROSTATIC
SENSITIVE
DEVICES

ESD CODE.

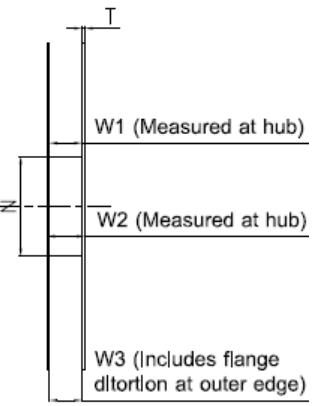
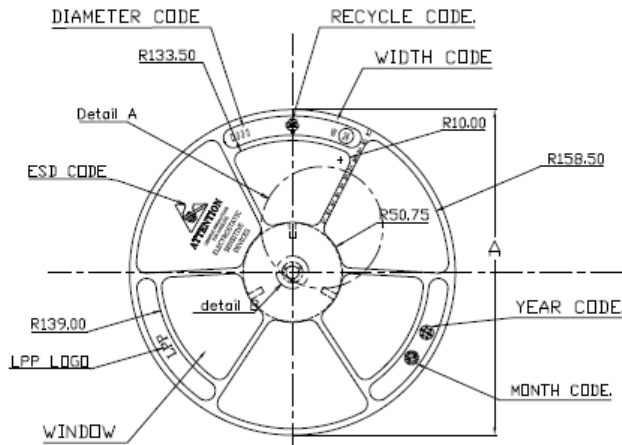
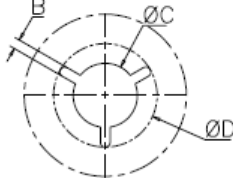


MONTH CODE.



YEAR CODE.

Detail B
Scale 5:1



D330

REEL DIAMETER CODE (mm.)



RECYCLE CODE.

W AA / B

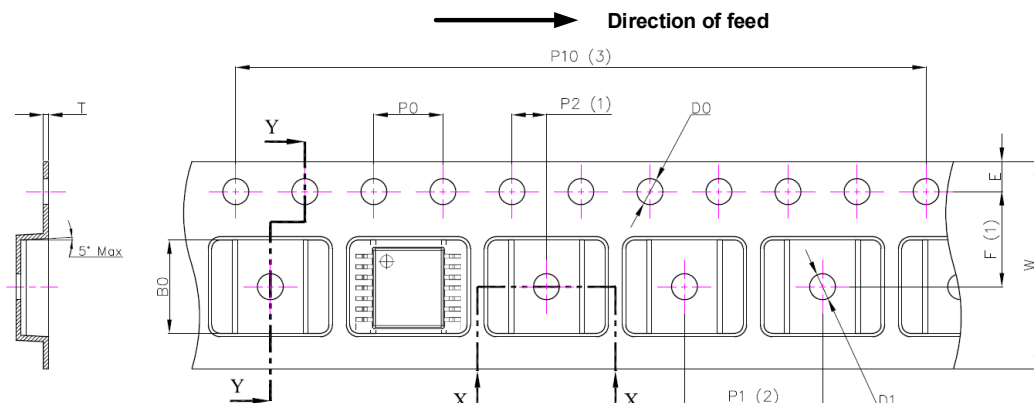
HUB DIAMETER (Inch.)
CARRIER TAPE WIDTH (mm.)

DETAIL A
SCALE 2:1

REEL WIDTH CODE

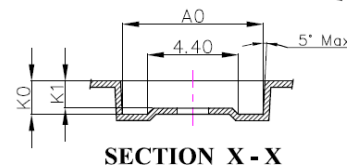
PART NUMBER	øA ±2.00	øN ±2.00	B $\begin{smallmatrix} +0.50 \\ -0.00 \end{smallmatrix}$	øC ±0.20	øD ±0.20	E (Min)	F (Min)	T (Min)	W1 $\begin{smallmatrix} +2.00 \\ -0.00 \end{smallmatrix}$	W2 (Max)	W3 (Max)	
											Min	Max
R13-12-04-E	330.00	100.00	2.20	13.00	21.00	5.50	10.00	2.40	12.40	18.40	12.35	15.40

Carrier Tape: Material: Polycarbonate, conductive, Width: 12 mm; Tape Leader: 440 mm; Tape Trailer: 360 mm



SECTION Y - Y

Dimension List			
Annote	Millimeter	Annote	Millimeter
A0	6.80±0.10	P1	8.00±0.10
B0	5.40±0.10	P2	2.00±0.10
D0	1.50 $\begin{smallmatrix} +0.10 \\ -0 \end{smallmatrix}$	P10	40.00±0.20
D1	1.50 MIN	E	1.75±0.10
K0	1.60±0.10	F	5.50±0.10
K1	1.30±0.10	W	12.00±0.30
P0	4.00±0.10	T	0.30±0.05



Cover Tape: Material: antistatic Polyester film; Width: 9.2 mm; Thickness: 0.050 mm

Figure 10-2 Tape & Reel diagram & orientation on tape

EM Microelectronic-Marin SA ("EM") makes no warranties for the use of EM products, other than those expressly contained in EM's applicable General Terms of Sale, located at <http://www.emmicroelectronic.com>. EM assumes no responsibility for any errors which may have crept into this document, reserves the right to change devices or specifications detailed herein at any time without notice, and does not make any commitment to update the information contained herein.

No licenses to patents or other intellectual property rights of EM are granted in connection with the sale of EM products, neither expressly nor implicitly.

In respect of the intended use of EM products by customer, customer is solely responsible for observing existing patents and other intellectual property rights of third parties and for obtaining, as the case may be, the necessary licenses.

Important note: The use of EM products as components in medical devices and/or medical applications, including but not limited to, safety and life supporting systems, where malfunction of such EM products might result in damage to and/or injury or death of persons is expressly prohibited, as EM products are neither destined nor qualified for use as components in such medical devices and/or medical applications. The prohibited use of EM products in such medical devices and/or medical applications is exclusively at the risk of the customer.