

ELR H5-IES-PT/500AC-3-IOL - Hybrid motor starter



2908669

<https://www.phoenixcontact.com/pc/products/2908669>

Please be informed that the data shown in this PDF document is generated from our online catalog. Please find the complete data in the user documentation. Our general terms of use for downloads are valid.



Networkable hybrid motor starter for reversing 3~ AC motors up to 500 V AC and 3 A output current, with adjustable overload shutdown, emergency stop function up to SIL 3/PL e, and Push-in connection. Connection to IO-Link.

Commercial data

Item number	2908669
Packing unit	1 pc
Minimum order quantity	1 pc
Product key	CK7432
Catalog page	Page 25 (C-5-2019)
GTIN	4055626321240
Weight per piece (including packing)	308.8 g
Weight per piece (excluding packing)	282.7 g
Customs tariff number	85371098
Country of origin	DE

ELR H5-IES-PT/500AC-3-IOL - Hybrid motor starter



2908669

<https://www.phoenixcontact.com/pc/products/2908669>

Technical data

Notes

General	If this device is to be used in combination with the CrossPowerSystem power distribution board, the device mount for the 16 A fuse (order designation: EM-CPS-DA-22,5F/16A; order number: 1002668) is required in order to attach the hybrid motor starter to the power distribution board.
---------	---

Product properties

Product type	Hybrid motor starters
Product family	CONTACTRON
Operating mode	100% operating factor

Electrical properties

Number of phases	3
Motor starter type	Reversing starter
Maximum power dissipation for nominal condition	12 W
Switching frequency	≤ 2 Hz (Load-dependent)
Maximum power dissipation	4.1 W
Minimum power dissipation	0.88 W
Coordination type	1

Supply

Rated control circuit supply voltage U_S	24 V DC
Control supply voltage range	19.2 V DC ... 30 V DC
Rated control supply current I_S	65 mA
Protective circuit	Surge protection Reverse polarity protection; Parallel polarity protection diode

Supply: IO-Link

Nominal voltage for I/O supply	24 V DC (This supply voltage is provided via the IO-Link interface of the IO-Link master.)
Current consumption	typ. 65 mA ±15 % (24 V DC) max. 150 mA
Protective circuit	Reverse polarity protection Short-circuit protection Overload protection

Insulation characteristics

Rated insulation voltage	550 V
Rated surge voltage	6 kV
Overvoltage category	III
Degree of pollution	2
Insulation characteristics between the control input and control supply voltage, and auxiliary circuit to the main circuit	Safe isolation (IEC 60947-1)

ELR H5-IES-PT/500AC-3-IOL - Hybrid motor starter



2908669

<https://www.phoenixcontact.com/pc/products/2908669>

Isolation characteristics between the control input and control supply voltage to auxiliary circuit	Safe isolation (IEC 60947-1) in the auxiliary circuit ≤ 300 V AC
	Safe isolation (EN 50178) in the auxiliary circuit ≤ 300 V AC
Emergency tripping	
Operate threshold	> 33 A
Response time	< 0.5 s

Input data

Control

Input name	Enable input
Rated actuating voltage U_C	24 V DC
Triggering voltage range	19.2 V DC ... 30 V DC
Rated actuating current I_C	7 mA
Switching threshold	9.6 V ("0" signal)
	19.2 V ("1" signal)
Switching level	< 5 V DC (For EMERGENCY STOP)
Typical turn-off time	< 30 ms

IO-Link

Number of ports	1
Connection method	COMBICON
Connection technology	3-conductor
Specification	V1.1.1
Reverse polarity protection	yes
Cycle Time	30 ms
Amount of process data	8 Byte (Input data)
	2 Byte (Output data)

Output data

AC output

Rated operating voltage U_e	500 V AC
Operating voltage range	42 V AC ... 550 V AC
Rated operating current I_e	3 A (AC-51)
	3 A (AC-53a)
Mains frequency	50/60 Hz
Load current range	180 mA ... 3 A (see to derating)
Trigger characteristic in acc. with IEC 60947-4-2	Class 10
Cooling time	20 min. (for auto reset)
Leakage current	0 mA
Protective circuit	Surge protection; Varistor

Connection data

Control circuits

Connection method	Push-in connection
-------------------	--------------------

ELR H5-IES-PT/500AC-3-IOL - Hybrid motor starter



2908669

<https://www.phoenixcontact.com/pc/products/2908669>

Stripping length	10 mm
Conductor cross section rigid	0.2 mm ² ... 2.5 mm ²
Conductor cross section flexible	0.2 mm ² ... 2.5 mm ²
Conductor cross section AWG	24 ... 14

Load circuit

Connection method	Push-in connection
Stripping length	10 mm
Conductor cross section rigid	0.2 mm ² ... 2.5 mm ²
Conductor cross section flexible	0.2 mm ² ... 2.5 mm ²
Conductor cross section AWG	24 ... 14

Signaling

Status display	Yellow LED
Operating voltage display	Green LED
Error indication	Red LED

Dimensions

Width	22.5 mm
Height	127 mm
Depth	114 mm

Material specifications

Flammability rating according to UL 94	V0 (Housing)
--	--------------

Environmental and real-life conditions

Ambient conditions

Degree of protection	IP20
Ambient temperature (operation)	-5 °C ... 55 °C (observe derating)
Ambient temperature (storage/transport)	-40 °C ... 80 °C
Altitude	≤ 2000 m

Approvals

UKCA

Certificate	UKCA-compliant
-------------	----------------

UL approval

Certificate	NLDX.E228652
	NRNT.E172140

Safety Integrity Level (SIL, IEC 61508)

Identification	≤ 3
Note	Safe shutdown

Performance Level (ISO 13849)

ELR H5-IES-PT/500AC-3-IOL - Hybrid motor starter



2908669

<https://www.phoenixcontact.com/pc/products/2908669>

Identification	e
Note	Safe shutdown

Category (ISO 13849)

Identification	≤ 3
Note	Safe shutdown

UL data

SCCR	100 kA (480 V AC (fuse: 30 A class CC/30 A class J (high fault)))
	5 kA (480 V AC (fuse: 20 A RK5 (standard fault)))
FLA	3 A (480 V AC)
Group installation	20 A (class RK5, SCCR 5kA (480 V AC), #24 - 14 AWG max. solid and stranded)
	30 A (class CC or J, SCCR 100kA (480 V AC), #24 - 14 AWG max. solid and stranded)
Category code	NLDX / NRNT
Horsepower ratings	0.5 hp (208 V AC)
	0.5 hp (230 V AC)
	0.5 hp (240 V AC)
	1.5 hp (480 V AC)

Standards and regulations

Standards/regulations

Standards/regulations	IEC 60947-1
	EN 60947-4-2
	IEC 61508
	ISO 13849

Mounting

Mounting type	DIN rail mounting
Assembly instructions	alignable, for spacing see derating
Mounting position	vertical (horizontal DIN rail, motor output below)

Drawings

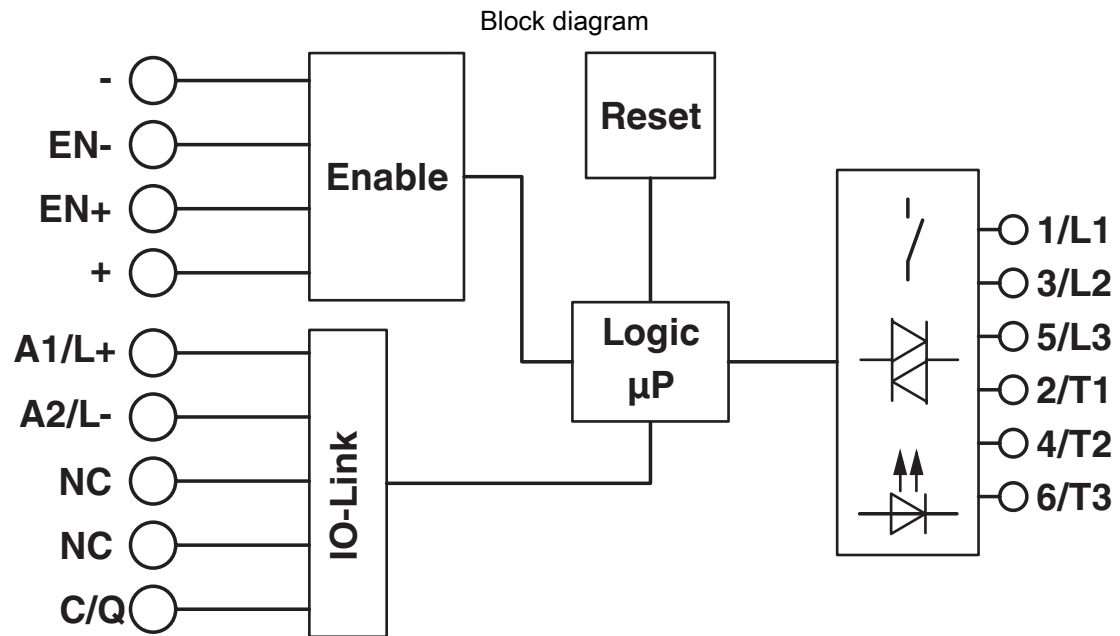

ELR H5-IES-PT/500AC-3-IOL - Hybrid motor starter



2908669

<https://www.phoenixcontact.com/pc/products/2908669>

Approvals

To download certificates, visit the product detail page: <https://www.phoenixcontact.com/pc/products/2908669>



IECEE CB Scheme

Approval ID: DE1-60807



EAC

Approval ID: RU*C-DE.*08.B.00520*



IECEE CB Scheme

Approval ID: DE1-60164



UL Listed

Approval ID: FILE E 172140



CCC

Approval ID: 2016010304900298



cUL Listed

Approval ID: FILE E 172140



cUL Listed

Approval ID: FILE E 228652



UL Listed

Approval ID: FILE E 228652

ELR H5-IES-PT/500AC-3-IOL - Hybrid motor starter



2908669

<https://www.phoenixcontact.com/pc/products/2908669>

Classifications

ECLASS

ECLASS-11.0	27370905
ECLASS-12.0	27370905
ECLASS-13.0	27370905

ETIM

ETIM 9.0	EC001037
----------	----------

UNSPSC

UNSPSC 21.0	25173900
-------------	----------

ELR H5-IES-PT/500AC-3-IOL - Hybrid motor starter



2908669

<https://www.phoenixcontact.com/pc/products/2908669>

Environmental product compliance

REACH SVHC	Lead 7439-92-1
China RoHS	Environmentally Friendly Use Period = 50 years
	For information on hazardous substances, refer to the manufacturer's declaration available under "Downloads"

ELR H5-IES-PT/500AC-3-IOL - Hybrid motor starter



2908669

<https://www.phoenixcontact.com/pc/products/2908669>

Accessories

BRIDGE-PT 1 - Bridge

1161777

<https://www.phoenixcontact.com/pc/products/1161777>

3-phase loop bridge for 1 CONTACTRON module, with Push-in connection and 22.5 mm housing width, connecting cable: 3 m



BRIDGE-PT 2 - Bridge

2904490

<https://www.phoenixcontact.com/pc/products/2904490>

3-phase loop bridge for 2 CONTACTRON modules, with Push-in connection and 22.5 mm housing width, connecting cable: 3 m



ELR H5-IES-PT/500AC-3-IOL - Hybrid motor starter



2908669

<https://www.phoenixcontact.com/pc/products/2908669>

BRIDGE-PT 3 - Bridge

2904491

<https://www.phoenixcontact.com/pc/products/2904491>

3-phase loop bridge for 3 CONTACTRON modules, with Push-in connection and 22.5 mm housing width, connecting cable: 3 m



BRIDGE-PT 4 - Bridge

2904492

<https://www.phoenixcontact.com/pc/products/2904492>

3-phase loop bridge for 4 CONTACTRON modules, with Push-in connection and 22.5 mm housing width, connecting cable: 3 m



ELR H5-IES-PT/500AC-3-IOL - Hybrid motor starter



2908669

<https://www.phoenixcontact.com/pc/products/2908669>

BRIDGE-PT 5 - Bridge

2904493

<https://www.phoenixcontact.com/pc/products/2904493>

3-phase loop bridge for 5 CONTACTRON modules, with Push-in connection and 22.5 mm housing width, connecting cable: 3 m



BRIDGE-PT 6 - Bridge

2904494

<https://www.phoenixcontact.com/pc/products/2904494>

3-phase loop bridge for 6 CONTACTRON modules, with Push-in connection and 22.5 mm housing width, connecting cable: 3 m



ELR H5-IES-PT/500AC-3-IOL - Hybrid motor starter



2908669

<https://www.phoenixcontact.com/pc/products/2908669>

BRIDGE-PT 7 - Bridge

2904495

<https://www.phoenixcontact.com/pc/products/2904495>

3-phase loop bridge for 7 CONTACTRON modules, with Push-in connection and 22.5 mm housing width, connecting cable: 3 m



BRIDGE-PT 8 - Bridge

2904496

<https://www.phoenixcontact.com/pc/products/2904496>

3-phase loop bridge for 8 CONTACTRON modules, with Push-in connection and 22.5 mm housing width, connecting cable: 3 m



ELR H5-IES-PT/500AC-3-IOL - Hybrid motor starter



2908669

<https://www.phoenixcontact.com/pc/products/2908669>

BRIDGE-PT 9 - Bridge

2904497

<https://www.phoenixcontact.com/pc/products/2904497>

3-phase loop bridge for 9 CONTACTRON modules, with Push-in connection and 22.5 mm housing width, connecting cable: 3 m



BRIDGE-PT 10 - Bridge

2904498

<https://www.phoenixcontact.com/pc/products/2904498>

3-phase loop bridge for 10 CONTACTRON modules, with Push-in connection and 22.5 mm housing width, connecting cable: 3 m



ELR H5-IES-PT/500AC-3-IOL - Hybrid motor starter



2908669

<https://www.phoenixcontact.com/pc/products/2908669>

BRIDGE-PT 1-1M - Bridge

1161778

<https://www.phoenixcontact.com/pc/products/1161778>

3-phase loop bridge for 1 CONTACTRON module, with Push-in connection and 22.5 mm housing width, connecting cable: 1 m



BRIDGE-PT-2-1M - Bridge

1049407

<https://www.phoenixcontact.com/pc/products/1049407>

3-phase loop bridge for 2 CONTACTRON modules, with Push-in connection and 22.5 mm housing width, connecting cable: 1 m



ELR H5-IES-PT/500AC-3-IOL - Hybrid motor starter



2908669

<https://www.phoenixcontact.com/pc/products/2908669>

BRIDGE-PT-3-1M - Bridge

1049408

<https://www.phoenixcontact.com/pc/products/1049408>

3-phase loop bridge for 3 CONTACTRON modules, with Push-in connection and 22.5 mm housing width, connecting cable: 1 m



BRIDGE-PT-4-1M - Bridge

1049409

<https://www.phoenixcontact.com/pc/products/1049409>

3-phase loop bridge for 4 CONTACTRON modules, with Push-in connection and 22.5 mm housing width, connecting cable: 1 m



ELR H5-IES-PT/500AC-3-IOL - Hybrid motor starter



2908669

<https://www.phoenixcontact.com/pc/products/2908669>

BRIDGE-PT-5-1M - Bridge

1049413

<https://www.phoenixcontact.com/pc/products/1049413>

3-phase loop bridge for 5 CONTACTRON modules, with Push-in connection and 22.5 mm housing width, connecting cable: 1 m



BRIDGE-PT-2-2M/0,3M - Bridge

1107649

<https://www.phoenixcontact.com/pc/products/1107649>

3-phase loop bridge for 2 CONTACTRON modules, with Push-in connection and 22.5 mm housing width, cable length between the modules: 0.3 m, connecting cable: 2 m



ELR H5-IES-PT/500AC-3-IOL - Hybrid motor starter



2908669

<https://www.phoenixcontact.com/pc/products/2908669>

BRIDGE-PT-3-2M/0,3M - Bridge

1107650

<https://www.phoenixcontact.com/pc/products/1107650>



3-phase loop bridge for 3 CONTACTRON modules, with Push-in connection and 22.5 mm housing width, cable length between the modules: 0.3 m, connecting cable: 2 m

BRIDGE-PT-4-2M/0,3M - Bridge

1107644

<https://www.phoenixcontact.com/pc/products/1107644>



3-phase loop bridge for 4 CONTACTRON modules, with Push-in connection and 22.5 mm housing width, cable length between the modules: 0.3 m, connecting cable: 2 m

ELR H5-IES-PT/500AC-3-IOL - Hybrid motor starter



2908669

<https://www.phoenixcontact.com/pc/products/2908669>

US-EMLP (15X5) - Plastic label

0828790

<https://www.phoenixcontact.com/pc/products/0828790>



Plastic label, Card, white, unlabeled, can be labeled with: BLUEMARK ID COLOR, BLUEMARK ID, THERMOMARK PRIME, THERMOMARK CARD 2.0, THERMOMARK CARD, mounting type: adhesive, lettering field size: 15 x 5 mm, Number of individual labels: 189

UC-EMLP (15X5) - Plastic label

0819301

<https://www.phoenixcontact.com/pc/products/0819301>



Plastic label, Sheet, white, unlabeled, can be labeled with: BLUEMARK ID COLOR, BLUEMARK ID, BLUEMARK CLED, PLOTMARK, CMS-P1-PLOTTER, mounting type: adhesive, lettering field size: 15 x 5 mm, Number of individual labels: 10

ELR H5-IES-PT/500AC-3-IOL - Hybrid motor starter



2908669

<https://www.phoenixcontact.com/pc/products/2908669>

IOL-CONF - Configuration and diagnostic software

1083065

<https://www.phoenixcontact.com/pc/products/1083065>



IOL-CONF is a browser-based configuration software tool for the easy startup of IO-Link masters and IO-Link devices

EM-CPS-225 - Power distribution board

1002634

<https://www.phoenixcontact.com/pc/products/1002634>

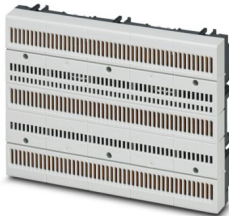

Modular power distribution board with CrossLink[®] interface, 125 A, 3-pos., touch-proof and protection against polarity reversal, width: 225 mm

ELR H5-IES-PT/500AC-3-IOL - Hybrid motor starter



2908669

<https://www.phoenixcontact.com/pc/products/2908669>

EM-CPS-405 - Power distribution board

1002635

<https://www.phoenixcontact.com/pc/products/1002635>

Modular power distribution board with CrossLink[®] interface, 125 A, 3-pos., touch-proof and protection against polarity reversal, width: 405 mm



EM-CPS-TB3/63A - Connection module

1002633

<https://www.phoenixcontact.com/pc/products/1002633>

Connection module with integrated spring-loaded terminals for cables from 1.5 to 16 mm², 3-pos., maximum 63 A



ELR H5-IES-PT/500AC-3-IOL - Hybrid motor starter

2908669

<https://www.phoenixcontact.com/pc/products/2908669>



EM-CPS-DA-22,5F/16A - Adapter

1002668

<https://www.phoenixcontact.com/pc/products/1002668>



Device adapter with fuse holder for 16 A fuse (10x38/Class CC), CrossLink[®] interface and fixed DIN rail

Phoenix Contact 2024 © - all rights reserved

<https://www.phoenixcontact.com>

PHOENIX CONTACT GmbH & Co. KG

Flachsmarktstraße 8

D-32825 Blomberg

+49 (0) 5235-3 00

info@phoenixcontact.com