

# ELR H5-I-PT/500AC-9-IFS - Hybrid motor starter



2905147

<https://www.phoenixcontact.com/pc/products/2905147>

Please be informed that the data shown in this PDF document is generated from our online catalog. Please find the complete data in the user documentation. Our general terms of use for downloads are valid.



Networkable hybrid motor starter for reversing 3~ AC motors up to 500 V AC, output current: 9 A, adjustable overload shutdown, and Push-in connection, DIN rail connector provided.

## Your advantages

- 22.5 mm wide
- Reduction in wiring
- Space saving
- Long service life
- 3-phase loop bridges
- Adjustable current for bimetal function
- Low-wear switching

## Commercial data

Item number	2905147
Packing unit	1 pc
Minimum order quantity	1 pc
Product key	CK7444
Catalog page	Page 25 (C-5-2019)
GTIN	4046356919562
Weight per piece (including packing)	290 g
Weight per piece (excluding packing)	282.7 g
Customs tariff number	85371098
Country of origin	DE

# ELR H5-I-PT/500AC-9-IFS - Hybrid motor starter



2905147

<https://www.phoenixcontact.com/pc/products/2905147>

## Technical data

### Product properties

Product type	Hybrid motor starters
Product family	CONTACTRON
Operating mode	100% operating factor

### Electrical properties

Number of phases	3
Motor starter type	Reversing starter
Maximum power dissipation for nominal condition	12 W
Switching frequency	≤ 2 Hz (Load-dependent)
Maximum power dissipation	7 W
Minimum power dissipation	0.88 W
Coordination type	1

### Supply

Rated control circuit supply voltage $U_S$	24 V DC
Control supply voltage range	19.2 V DC ... 30 V DC
Rated control supply current $I_S$	60 mA
Protective circuit	Surge protection Reverse polarity protection; Parallel polarity protection diode

### Insulation characteristics

Rated insulation voltage	550 V
Rated surge voltage	6 kV
Overvoltage category	III
Degree of pollution	2
Insulation characteristics between the control input and control supply voltage, and auxiliary circuit to the main circuit	Safe isolation (IEC 60947-1)
Isolation characteristics between the control input and control supply voltage to auxiliary circuit	Safe isolation (IEC 60947-1) in the auxiliary circuit ≤ 300 V AC

### Emergency tripping

Operate threshold	> 60 A
Response time	< 0.5 s

## Output data

### AC output

Rated operating voltage $U_e$	500 V AC
Operating voltage range	42 V AC ... 550 V AC
Rated operating current $I_e$	9 A (AC-51) 7 A (AC-53a)
Mains frequency	50/60 Hz
Load current range	1.5 A ... 9 A (see to derating)

# ELR H5-I-PT/500AC-9-IFS - Hybrid motor starter



2905147

<https://www.phoenixcontact.com/pc/products/2905147>

Trigger characteristic in acc. with IEC 60947-4-2	Class 10A
Cooling time	20 min. (for auto reset)
Leakage current	0 mA
Protective circuit	Surge protection; Varistor

## Connection data

### Control circuits

Connection method	Push-in connection
Stripping length	10 mm
Conductor cross section rigid	0.2 mm <sup>2</sup> ... 2.5 mm <sup>2</sup>
Conductor cross section flexible	0.2 mm <sup>2</sup> ... 2.5 mm <sup>2</sup>
Conductor cross section AWG	24 ... 14

### Load circuit

Connection method	Push-in connection
Stripping length	10 mm
Conductor cross section rigid	0.2 mm <sup>2</sup> ... 2.5 mm <sup>2</sup>
Conductor cross section flexible	0.2 mm <sup>2</sup> ... 2.5 mm <sup>2</sup>
Conductor cross section AWG	24 ... 14

## Signaling

Status display	Yellow LED
Operating voltage display	Green LED
Error indication	Red LED

## Dimensions

Width	22.5 mm
Height	107.5 mm
Depth	114 mm

## Material specifications

Flammability rating according to UL 94	V0 (Housing)
--	--------------

## Environmental and real-life conditions

### Ambient conditions

Degree of protection	IP20
Ambient temperature (operation)	-5 °C ... 60 °C (observe derating)
Ambient temperature (storage/transport)	-40 °C ... 80 °C
Altitude	≤ 2000 m

## Approvals

### UKCA

Certificate	UKCA-compliant
-------------	----------------

# ELR H5-I-PT/500AC-9-IFS - Hybrid motor starter



2905147

<https://www.phoenixcontact.com/pc/products/2905147>

## UL approval

Certificate	NLDX.E228652
	NRNT.E172140

## UL data

SCCR	100 kA (480 V AC (fuse: 30 A class CC/30 A class J (high fault)))
	5 kA (480 V AC (fuse: 20 A RK5 (standard fault)))
FLA	7.6 A (480 V AC)
Group installation	20 A (class RK5, SCCR 5kA (480 V AC), #24 - 14 AWG max. solid and stranded)
	30 A (class CC or J, SCCR 100kA (480 V AC), #24 - 14 AWG max, solid and stranded)
Category code	NLDX / NRNT
Horsepower ratings	2 hp (208 V AC)
	2 hp (230 V AC)
	2 hp (240 V AC)
	5 hp (480 V AC)

## Standards and regulations

### Standards/regulations

Standards/regulations	IEC 60947-1
	EN 60947-4-2

## Mounting

Mounting type	DIN rail mounting
Assembly instructions	alignable, for spacing see derating
Mounting position	vertical (horizontal DIN rail, motor output below)

## Drawings

Diagram

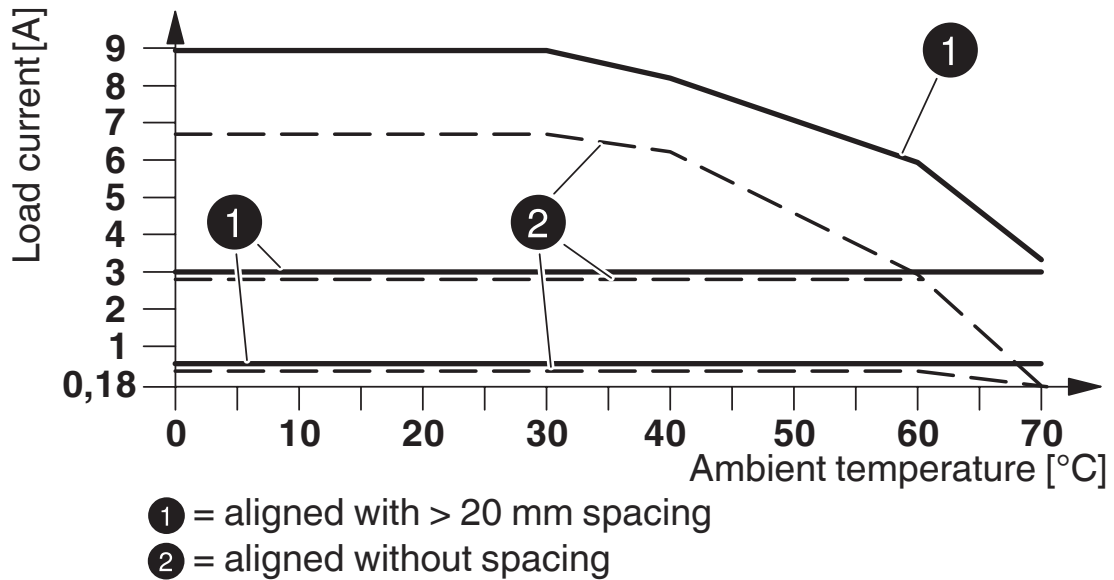

Derating diagram

Block diagram

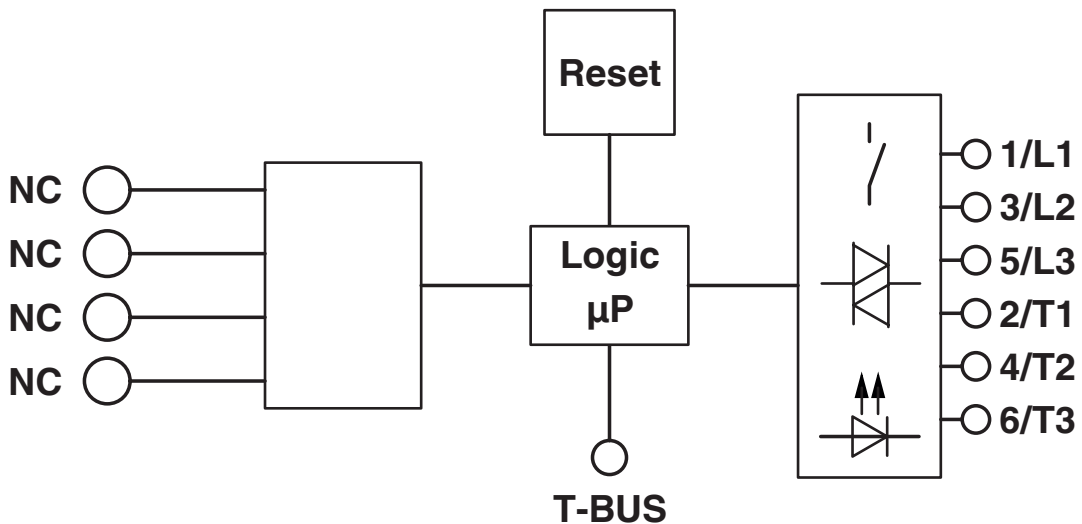

# ELR H5-I-PT/500AC-9-IFS - Hybrid motor starter



2905147

<https://www.phoenixcontact.com/pc/products/2905147>

## Classifications

### ECLASS

ECLASS-11.0	27370905
ECLASS-13.0	27370905
ECLASS-12.0	27370905

### ETIM

ETIM 9.0	EC001037
----------	----------

### UNSPSC

UNSPSC 21.0	25173900
-------------	----------

# ELR H5-I-PT/500AC-9-IFS - Hybrid motor starter



2905147

<https://www.phoenixcontact.com/pc/products/2905147>

## Environmental product compliance

REACH SVHC	Lead 7439-92-1
China RoHS	Environmentally Friendly Use Period = 50 years
	For information on hazardous substances, refer to the manufacturer's declaration available under "Downloads"

# ELR H5-I-PT/500AC-9-IFS - Hybrid motor starter



2905147

<https://www.phoenixcontact.com/pc/products/2905147>

## Accessories

### BRIDGE-PT 1 - Bridge

1161777

<https://www.phoenixcontact.com/pc/products/1161777>

3-phase loop bridge for 1 CONTACTRON module, with Push-in connection and 22.5 mm housing width, connecting cable: 3 m



---

### BRIDGE-PT 2 - Bridge

2904490

<https://www.phoenixcontact.com/pc/products/2904490>

3-phase loop bridge for 2 CONTACTRON modules, with Push-in connection and 22.5 mm housing width, connecting cable: 3 m





# ELR H5-I-PT/500AC-9-IFS - Hybrid motor starter



2905147

<https://www.phoenixcontact.com/pc/products/2905147>

## BRIDGE-PT 3 - Bridge

2904491

<https://www.phoenixcontact.com/pc/products/2904491>

3-phase loop bridge for 3 CONTACTRON modules, with Push-in connection and 22.5 mm housing width, connecting cable: 3 m



---

## BRIDGE-PT 4 - Bridge

2904492

<https://www.phoenixcontact.com/pc/products/2904492>

3-phase loop bridge for 4 CONTACTRON modules, with Push-in connection and 22.5 mm housing width, connecting cable: 3 m



# ELR H5-I-PT/500AC-9-IFS - Hybrid motor starter



2905147

<https://www.phoenixcontact.com/pc/products/2905147>

## BRIDGE-PT 5 - Bridge

2904493

<https://www.phoenixcontact.com/pc/products/2904493>

3-phase loop bridge for 5 CONTACTRON modules, with Push-in connection and 22.5 mm housing width, connecting cable: 3 m



---

## BRIDGE-PT 6 - Bridge

2904494

<https://www.phoenixcontact.com/pc/products/2904494>

3-phase loop bridge for 6 CONTACTRON modules, with Push-in connection and 22.5 mm housing width, connecting cable: 3 m



# ELR H5-I-PT/500AC-9-IFS - Hybrid motor starter



2905147

<https://www.phoenixcontact.com/pc/products/2905147>

## BRIDGE-PT 7 - Bridge

2904495

<https://www.phoenixcontact.com/pc/products/2904495>

3-phase loop bridge for 7 CONTACTRON modules, with Push-in connection and 22.5 mm housing width, connecting cable: 3 m



---

## BRIDGE-PT 8 - Bridge

2904496

<https://www.phoenixcontact.com/pc/products/2904496>

3-phase loop bridge for 8 CONTACTRON modules, with Push-in connection and 22.5 mm housing width, connecting cable: 3 m



# ELR H5-I-PT/500AC-9-IFS - Hybrid motor starter



2905147

<https://www.phoenixcontact.com/pc/products/2905147>

## BRIDGE-PT 9 - Bridge

2904497

<https://www.phoenixcontact.com/pc/products/2904497>

3-phase loop bridge for 9 CONTACTRON modules, with Push-in connection and 22.5 mm housing width, connecting cable: 3 m



---

## BRIDGE-PT 10 - Bridge

2904498

<https://www.phoenixcontact.com/pc/products/2904498>

3-phase loop bridge for 10 CONTACTRON modules, with Push-in connection and 22.5 mm housing width, connecting cable: 3 m



# ELR H5-I-PT/500AC-9-IFS - Hybrid motor starter



2905147

<https://www.phoenixcontact.com/pc/products/2905147>

## BRIDGE-PT 1-1M - Bridge

1161778

<https://www.phoenixcontact.com/pc/products/1161778>

3-phase loop bridge for 1 CONTACTRON module, with Push-in connection and 22.5 mm housing width, connecting cable: 1 m



---

## BRIDGE-PT-2-1M - Bridge

1049407

<https://www.phoenixcontact.com/pc/products/1049407>

3-phase loop bridge for 2 CONTACTRON modules, with Push-in connection and 22.5 mm housing width, connecting cable: 1 m



# ELR H5-I-PT/500AC-9-IFS - Hybrid motor starter



2905147

<https://www.phoenixcontact.com/pc/products/2905147>

## BRIDGE-PT-3-1M - Bridge

1049408

<https://www.phoenixcontact.com/pc/products/1049408>

3-phase loop bridge for 3 CONTACTRON modules, with Push-in connection and 22.5 mm housing width, connecting cable: 1 m



---

## BRIDGE-PT-4-1M - Bridge

1049409

<https://www.phoenixcontact.com/pc/products/1049409>

3-phase loop bridge for 4 CONTACTRON modules, with Push-in connection and 22.5 mm housing width, connecting cable: 1 m



# ELR H5-I-PT/500AC-9-IFS - Hybrid motor starter



2905147

<https://www.phoenixcontact.com/pc/products/2905147>

## BRIDGE-PT-5-1M - Bridge

1049413

<https://www.phoenixcontact.com/pc/products/1049413>

3-phase loop bridge for 5 CONTACTRON modules, with Push-in connection and 22.5 mm housing width, connecting cable: 1 m



---

## BRIDGE-PT-2-2M/0,3M - Bridge

1107649

<https://www.phoenixcontact.com/pc/products/1107649>

3-phase loop bridge for 2 CONTACTRON modules, with Push-in connection and 22.5 mm housing width, cable length between the modules: 0.3 m, connecting cable: 2 m



# ELR H5-I-PT/500AC-9-IFS - Hybrid motor starter



2905147

<https://www.phoenixcontact.com/pc/products/2905147>

## BRIDGE-PT-3-2M/0,3M - Bridge

1107650

<https://www.phoenixcontact.com/pc/products/1107650>



3-phase loop bridge for 3 CONTACTRON modules, with Push-in connection and 22.5 mm housing width, cable length between the modules: 0.3 m, connecting cable: 2 m

---

## BRIDGE-PT-4-2M/0,3M - Bridge

1107644

<https://www.phoenixcontact.com/pc/products/1107644>



3-phase loop bridge for 4 CONTACTRON modules, with Push-in connection and 22.5 mm housing width, cable length between the modules: 0.3 m, connecting cable: 2 m



# ELR H5-I-PT/500AC-9-IFS - Hybrid motor starter



2905147

<https://www.phoenixcontact.com/pc/products/2905147>

## US-EMLP (15X5) - Plastic label

0828790

<https://www.phoenixcontact.com/pc/products/0828790>



Plastic label, Card, white, unlabeled, can be labeled with: BLUEMARK ID COLOR, BLUEMARK ID, THERMOMARK PRIME, THERMOMARK CARD 2.0, THERMOMARK CARD, mounting type: adhesive, lettering field size: 15 x 5 mm, Number of individual labels: 189

---

## UC-EMLP (15X5) - Plastic label

0819301

<https://www.phoenixcontact.com/pc/products/0819301>



Plastic label, Sheet, white, unlabeled, can be labeled with: BLUEMARK ID COLOR, BLUEMARK ID, BLUEMARK CLED, PLOTMARK, CMS-P1-PLOTTER, mounting type: adhesive, lettering field size: 15 x 5 mm, Number of individual labels: 10

# ELR H5-I-PT/500AC-9-IFS - Hybrid motor starter



2905147

<https://www.phoenixcontact.com/pc/products/2905147>

## ME 22,5 TBUS 1,5/ 5-ST-3,81 GY - DIN rail bus connectors

2201937

<https://www.phoenixcontact.com/pc/products/2201937>

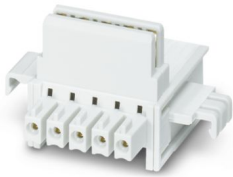

DIN rail connector, color: gray, nominal current: 8 A (parallel contacts), rated voltage (III/2): 125 V, number of positions: 5, pitch: 3.81 mm, mounting: DIN rail mounting, locking: without, mounting: without, type of packaging: packed in cardboard, Item with gold-plated contacts, bus connectors for connecting with electronics housings, 5 parallel contacts

---

## EM-PB-GATEWAY-IFS - Data interface

2297620

<https://www.phoenixcontact.com/pc/products/2297620>



Gateway for the connection of up to 32 INTERFACE system devices to a higher-level controller via PROFIBUS DP. The INTERFACE system devices are connected to the Gateway via DIN rail connectors, the DIN rail connectors are provided.

# ELR H5-I-PT/500AC-9-IFS - Hybrid motor starter



2905147

<https://www.phoenixcontact.com/pc/products/2905147>

## EM-CAN-GATEWAY-IFS - Data interface

2901504

<https://www.phoenixcontact.com/pc/products/2901504>



Gateway for the connection of up to 32 INTERFACE system devices to a higher-level controller via CANopen<sup>®</sup>. The INTERFACE system devices are connected to the Gateway via DIN rail connectors, the DIN rail connectors are provided.

---

## EM-MODBUS-GATEWAY-IFS - Data interface

2901528

<https://www.phoenixcontact.com/pc/products/2901528>



Gateway for the connection of up to 32 INTERFACE system devices via Modbus/TCP to a higher-level controller. The INTERFACE system devices are connected to the Gateway via DIN rail connectors, the DIN rail connectors are provided.

# ELR H5-I-PT/500AC-9-IFS - Hybrid motor starter



2905147

<https://www.phoenixcontact.com/pc/products/2905147>

## EM-PNET-GATEWAY-IFS - Data interface

2904472

<https://www.phoenixcontact.com/pc/products/2904472>



Gateway for the connection of up to 32 INTERFACE system devices via PROFINET to a higher-level controller. The INTERFACE system devices are connected to the Gateway via DIN rail connectors, the DIN rail connectors are provided.

---

## EM-ETH-GATEWAY-IFS - Data interface

2901988

<https://www.phoenixcontact.com/pc/products/2901988>



Gateway for the connection of up to 32 INTERFACE system devices to a higher-level controller via EtherNet/IP™. The INTERFACE system devices are connected to the Gateway via DIN rail connectors, the DIN rail connectors are provided.

# ELR H5-I-PT/500AC-9-IFS - Hybrid motor starter



2905147

<https://www.phoenixcontact.com/pc/products/2905147>

## EM-D-8/4-24DC-IFS - Extension module

2904473

<https://www.phoenixcontact.com/pc/products/2904473>



For more complex applications with Interface system devices (IFS), the extension module offers digital inputs and outputs for processing additional signals in the field. Easy connection to IFS gateway via the DIN rail connector as the slave.

---

## QUINT4-SYS-PS/1AC/24DC/2.5/SC - Power supply unit

2904614

<https://www.phoenixcontact.com/pc/products/2904614>



Primary-switched power supply, QUINT POWER, screw connection, DIN rail mounting, supply of devices possible via the TBUS DIN rail connector, protective coating, input: single-phase, output: 24 V DC/2.5 A

# ELR H5-I-PT/500AC-9-IFS - Hybrid motor starter

2905147

<https://www.phoenixcontact.com/pc/products/2905147>



## ME 22,5 TBUS ADAPTER KMGY - DIN rail bus connectors

2201756

<https://www.phoenixcontact.com/pc/products/2201756>

DIN rail bus adapter for ME and ME-MAX, design width: 22.5 mm, 5 parallel positions, color: light gray (similar to RAL 7035)

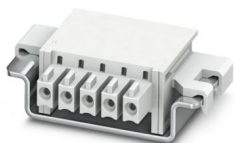

---

Phoenix Contact 2024 © - all rights reserved

<https://www.phoenixcontact.com>

PHOENIX CONTACT GmbH & Co. KG

Flachsmarktstraße 8

D-32825 Blomberg

+49 (0) 5235-3 00

[info@phoenixcontact.com](mailto:info@phoenixcontact.com)