

## Microprocessor Supervisory Circuit with Pull Up Resistor

### FEATURES

- Holds Microcontroller in Reset
- Reset Microcontroller during power loss
- 4.375 and 3.075 Voltage Trip Points
- Active Low  $\overline{\text{RESET}}$  Pin
- Internal Pull-up Resistor
- Holds  $\overline{\text{RESET}}$  for 350ms (typical)
- $\overline{\text{RESET}}$  valid down to  $V_{\text{DD}} 1.0\text{V}$
- 45 $\mu\text{A}$  Typical Operating Current
- Offered in a 3 Pin SOT-23 Package

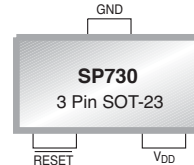

Now Available in Lead Free Packaging

### APPLICATIONS

- Portable Electronic Devices
- Electrical Power Meter
- Computer System Board
- Modem

### DESCRIPTION

The SP730 is a voltage supervisory device designed to keep a microcontroller in reset until the system voltage has reached the proper level and stabilized. It also operates as protection from brown-out conditions when the supply voltage drops below a safe operating level. The SP730 has an internal 5k $\Omega$  pull-up resistor. The device has an active low  $\overline{\text{RESET}}$  pin and will assert the  $\overline{\text{RESET}}$  signal whenever the voltage on the  $V_{\text{DD}}$  pin is below the trip-point voltage. The part is available in a small 3 pin SOT-23 package. Contact factory for other trip voltage options.

### TYPICAL APPLICATION CIRCUIT

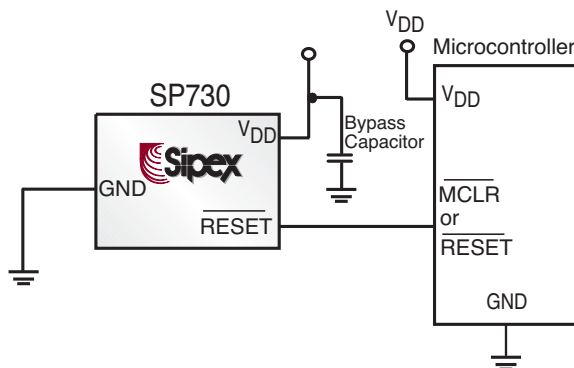

## ABSOLUTE MAXIMUM RATINGS

$V_{DD}$ .....	6.0V
All inputs and outputs w.r.t. GND .....	-0.6 to $V_{DD}$ + 1.0V
Storage Temperature .....	-65°C to +150°C
Ambient Temperature with power applied.....	-65°C to +125°C
ESD Protection on all pins .....	$\geq 2$ kV

These are stress ratings only and functional operation of the device at these ratings or any other above those indicated in the operation sections of the specifications below is not implied. Exposure to absolute maximum rating conditions for extended periods of time may affect reliability.

## ELECTRICAL CHARACTERISTICS

$V_{DD} = 1.0V - 5.5V$  ; -40°C to 85°C. The ♦ denotes the specifications which apply over the full operating temperature range, unless otherwise specified.

Parameter	Symbol	Min.	Typ.	Max.		Units	Conditions
Operating Voltage Range	$V_{DD}$	1.0		5.5	♦	V	
$V_{DD}$ Value to $\overline{\text{RESET}}$	$V_{DDMIN}$	1.0			♦	V	
Operating Current	$I_{DD}$		45	60	♦	$\mu A$	$V_{DD} = 5.5V$ (no load)
$V_{DD}$ Trip Point	$V_{TRIP}$	3.0	3.075	3.15	♦	V	
		4.25	4.375	4.50	♦		
Threshold Hysteresis	$V_{HYS}$		50		♦	mV	
$\overline{\text{RESET}}$ Low Level Output Voltage	$V_{OL}$			0.6	♦	V	$I_{OL} = 8.5mA$ , $V_{DD} = V_{TRIP MIN}$
$\overline{\text{RESET}}$ High Level Output Voltage	$V_{OH}$	$V_{DD} - .7$			♦	V	$I_{OH} = 50\mu A$ , $V_{DD} > V_{TRIP MAX}$
Pull up Resistor			5		♦	K $\Omega$	
$V_{DD}$ Detect to $\overline{\text{RESET}}$ Inactive	$t_{RPU}$	150	350	700	♦	ms	
$V_{DD}$ Detect to $\overline{\text{RESET}}$	$t_{RPD}$		10		♦	$\mu S$	$V_{DD}$ ramped from $V_{TRIP MAX}$ ( $V_{TRIP MAX} + 250mV$ ) to ( $V_{TRIP MIN} - 250mV$ )

## PIN DESCRIPTION

PIN NUMBER	PIN NAME	3 PIN SOT-23 DESCRIPTION
1	$\overline{\text{RESET}}$	Active Low. This pin goes low whenever $V_{DD}$ falls below the reset threshold.
2	$V_{DD}$	Supply input.
3	GND	Ground.

## FUNCTIONAL DIAGRAM

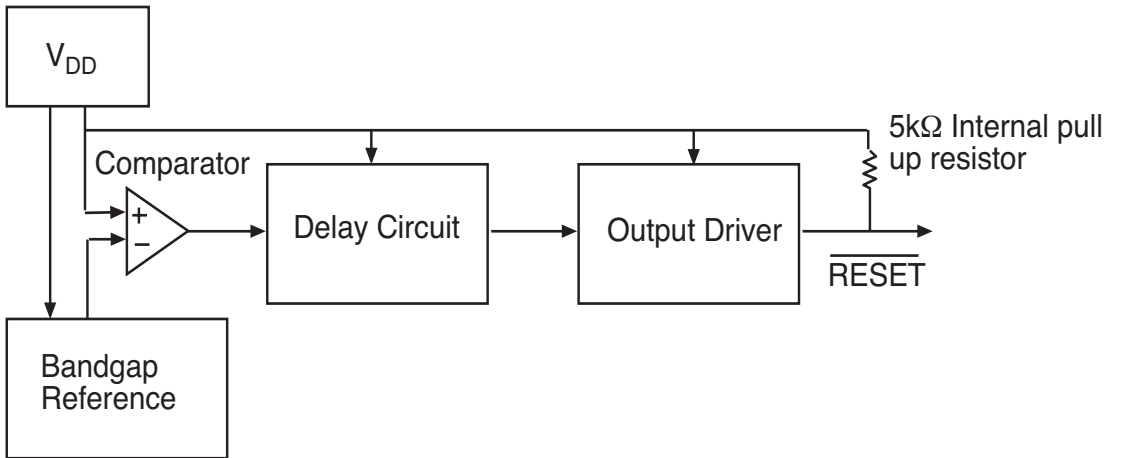

## TIMING DIAGRAM

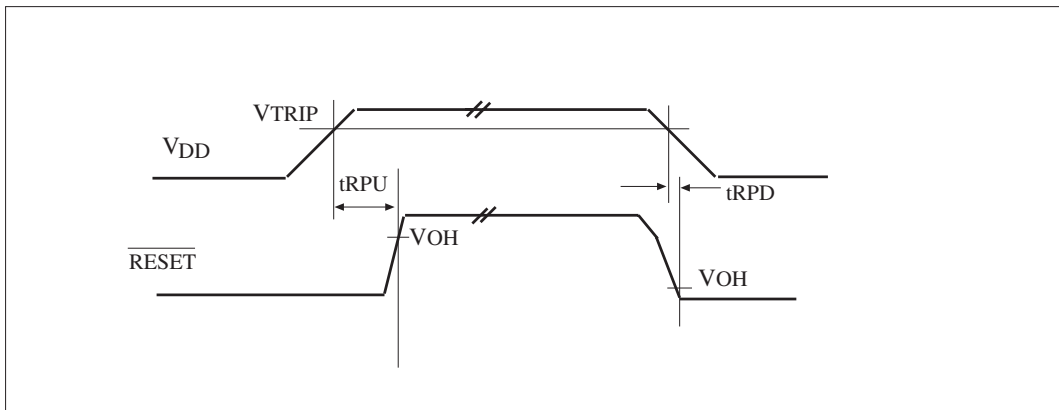

**Figure 1: SP730 Timing Diagram**

# TYPICAL PERFORMANCE CHARACTERISTICS

### I<sub>dd</sub> vs Temperature

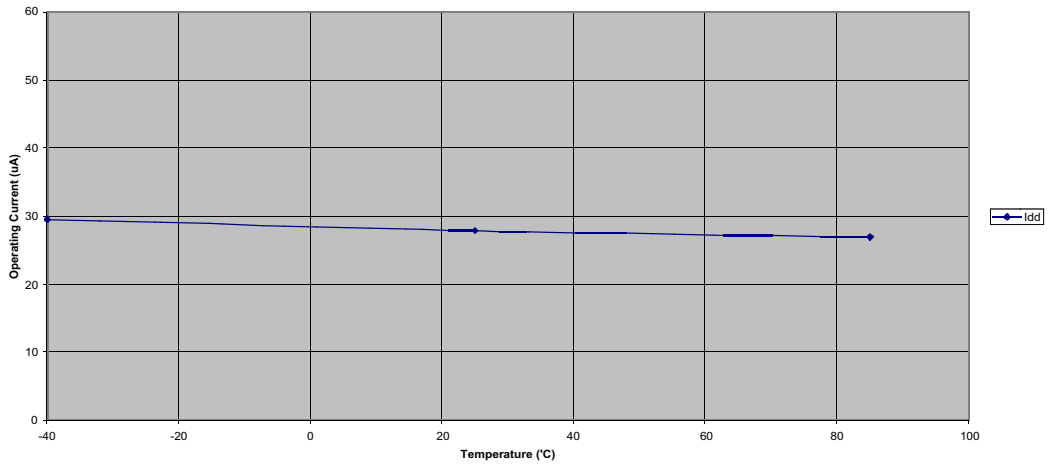

### t<sub>RPU</sub> vs Temperature

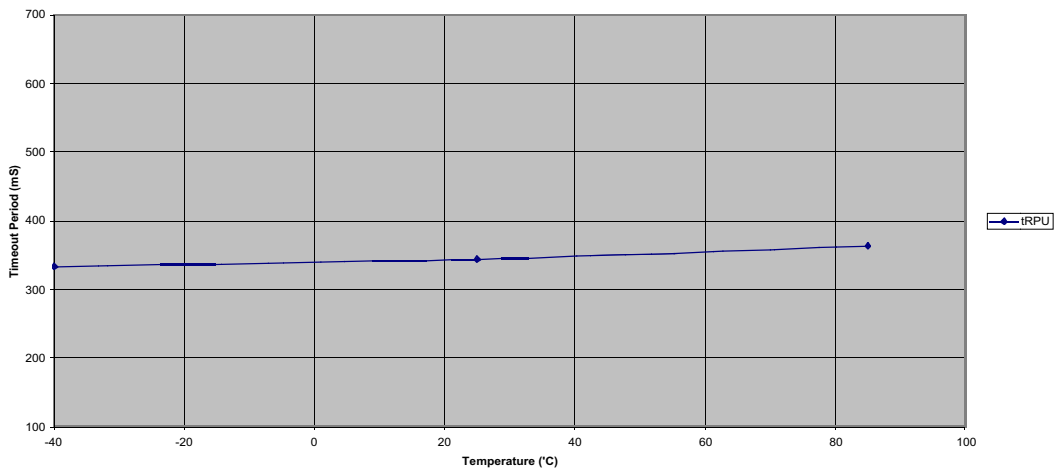

Normalized VTRIP vs Temperature

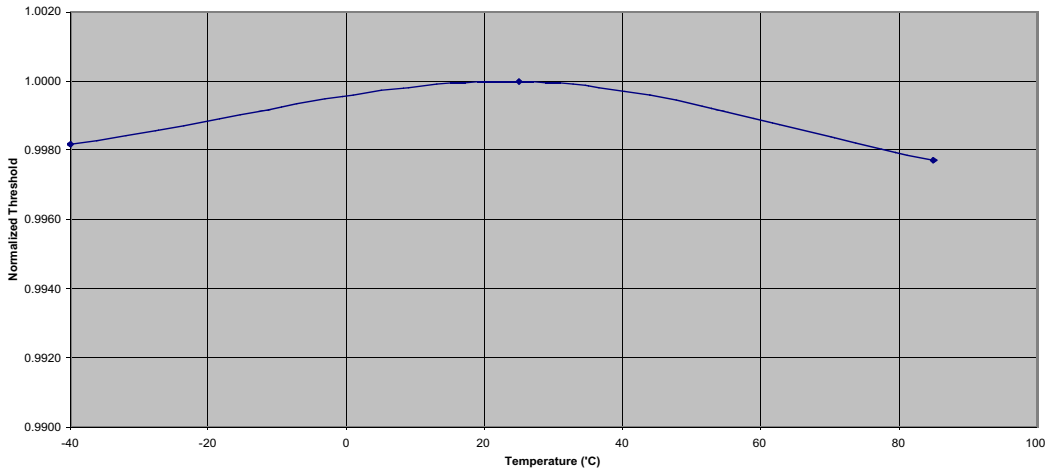

VOL vs IOL

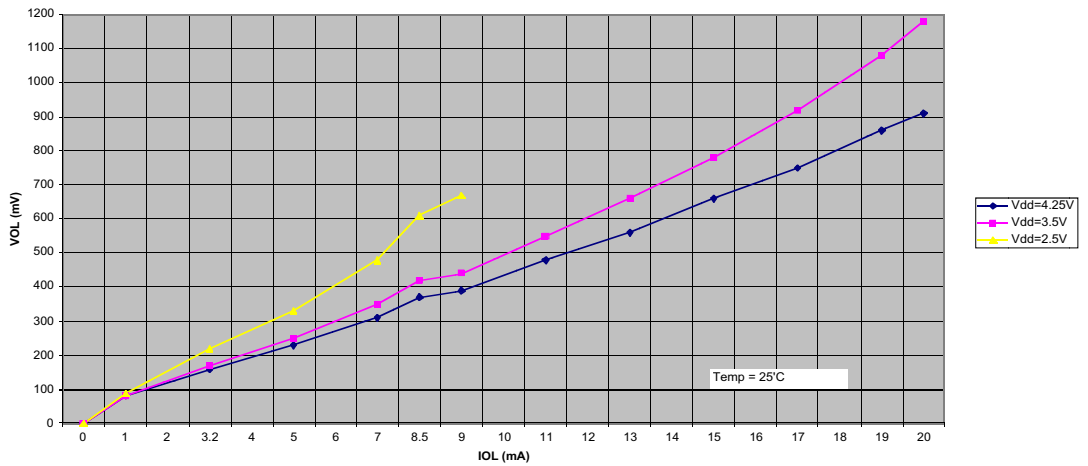

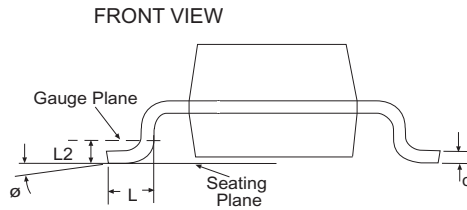
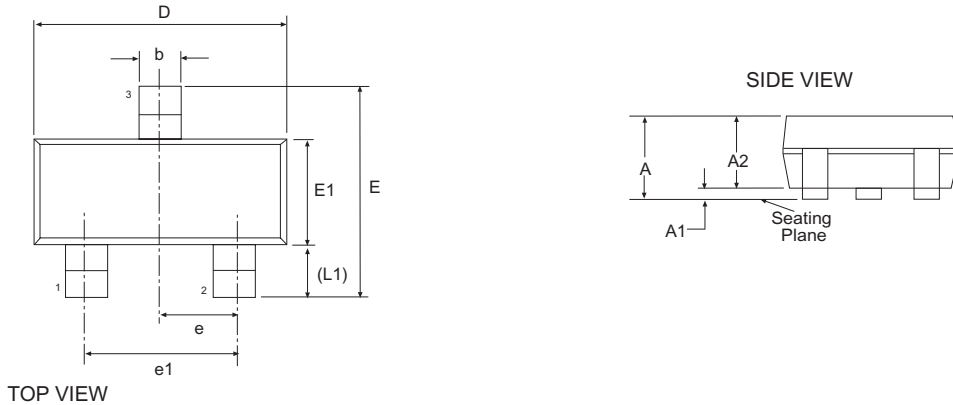

3 Pin SOT-23		JEDEC TO-236		Variation AB		
SYMBOL	Dimensions in Millimeters: Controlling Dimension			Dimensions in Inches Conversion Factor: 1 Inch = 25.40 mm		
	MIN	NOM	MAX	MIN	NOM	MAX
b	0.30	-	0.50	0.012	-	0.020
c	0.08	-	0.20	0.003	-	0.008
D	2.80	2.90	3.04	0.110	0.114	0.120
E	2.10	-	2.64	0.083	-	0.104
E1	1.20	1.30	1.40	0.047	0.051	0.055
e	0.95 BSC			0.038 BSC		
e1	1.90 BSC			0.075 BSC		
L	0.40	0.50	0.60	0.016	0.020	0.024
L1	0.54 REF			0.021 REF		
L2	0.25 BSC			0.010 BSC		
∅	0°	-	8°	0°	-	8°
A	0.89	-	1.12	0.035	-	0.044
A1	0.01	-	0.10	0.000	-	0.004
A2	0.88	0.95	1.02	0.035	0.037	0.040
SIPEX Pkg Signoff Date/Rev:				JL Oct25-05 / Rev A		

---

**ORDERING INFORMATION**

<b>Part number</b>	<b>Top Mark</b>	<b>Temperature</b>	<b>Vout</b>	<b>Package</b>
SP730EK-4-375.....	V3WW.....	-40°-85°.....	4.375V.....	3 Pin SOT-23
SP730EK-4-375/TR.....	V3WW.....	-40°-85°.....	4.375V.....	3 Pin SOT-23
SP730EK-3-075.....	M4WW.....	-40°-85°.....	3.075V.....	3 Pin SOT-23
SP730EK-3-075/TR.....	M4WW.....	-40°-85°.....	3.075V.....	3 Pin SOT-23

Contact factory for other trip voltage options.

Available in lead free packaging. To order add "-L" suffix to part number.

Example: SP730EK-4-375/TR = standard; SP730EK-L-4-375/TR = lead free

/TR = Tape and Reel

Pack quantity is 2500 for SOT-23.



Solved By Sipex™

**Sipex Corporation**

**Headquarters and  
Sales Office**

233 South Hillview Drive  
Milpitas, CA 95035  
TEL: (408) 934-7500  
FAX: (408) 935-7600