

Customer Information Sheet

IF IN DOUBT - ASK

©

NOT TO SCALE

THIRD ANGLE PROJECTION

ALL DIMENSIONS IN mm

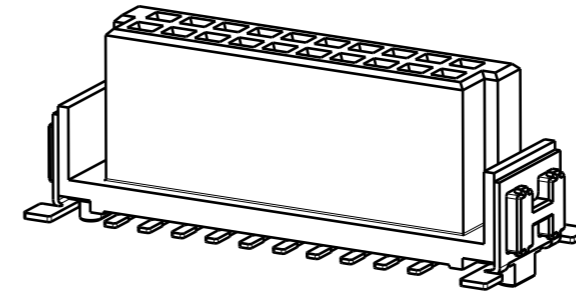
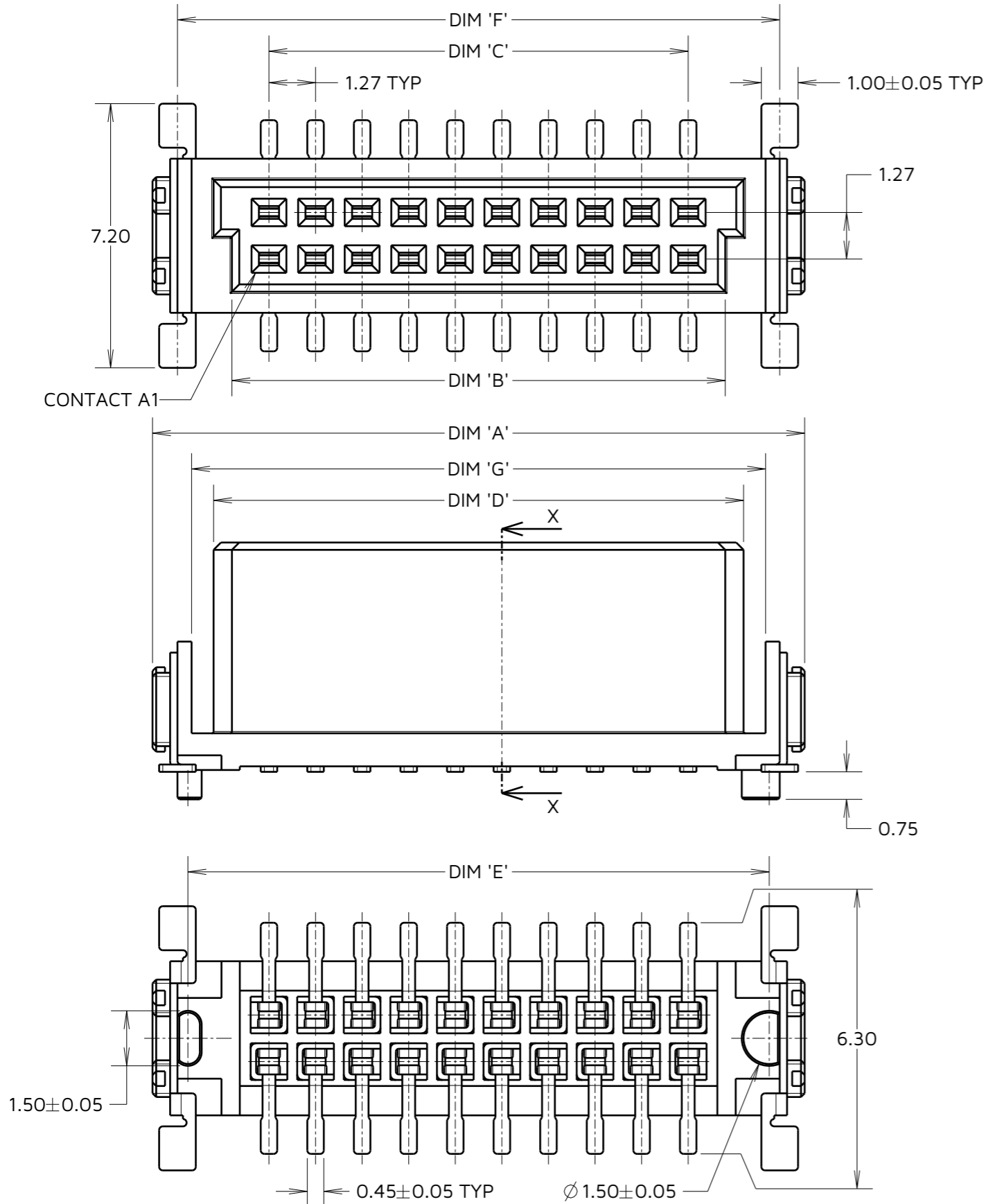

CAP HAS BEEN HIDDEN FOR ILLUSTRATION PURPOSES ONLY. SEE NOTE 1

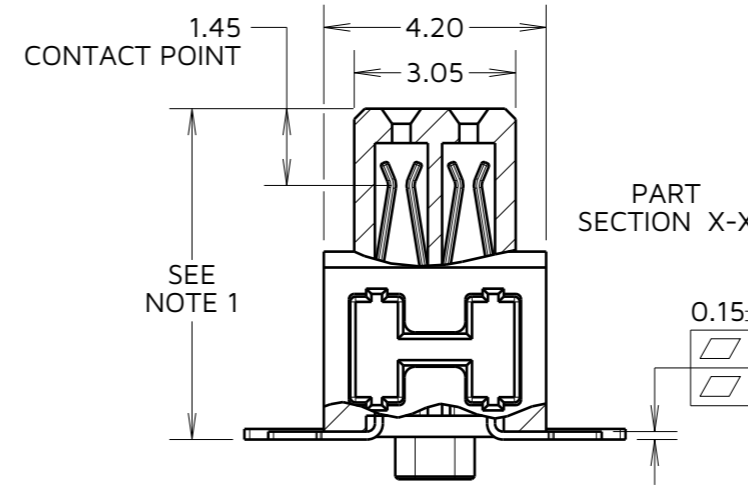

0.15±0.02	0.1	12 - 50 CONTACTS
0.15±0.02	0.15	68 - 80 CONTACTS

SPECIFICATIONS:

MATERIAL:

MOULDING & CAP = HIGH TEMP, LCP, UL94V-0
CONTACT = PHOSPHOR BRONZE
RETAINING STRAP = BRASS

PLATING:

CONTACT = 0.025µm MIN GOLD OVER
2.03µm MIN NICKEL ON CONTACT AREA,
2.54µm MIN TIN OVER
1.27µm MIN NICKEL ON TAILS
RETAINING STRAP = 2.45µm MIN TIN OVER
1.01µm MIN NICKEL

ORDER CODE:

M55-60XXX42R

CONNECTOR HEIGHT:

0 = 6.25
1 = 9.05
2 = 13.65

TOTAL No. OF CONTACTS:

12, 16, 20, 26,
32, 40, 50, 68, 80

PART No.	DIM 'A'	DIM 'B'	DIM 'C'	DIM 'D'	DIM 'E'	DIM 'F'	DIM 'G'
M55-60X1242R	12.70	8.37	6.35	9.37	10.77	11.34	10.57
M55-60X1642R	15.24	10.91	8.89	11.91	13.31	13.88	13.11
M55-60X2042R	17.78	13.45	11.43	14.45	15.85	16.42	15.65
M55-60X2642R	21.59	17.26	15.24	18.26	19.66	20.23	19.46
M55-60X3242R	25.40	21.07	19.05	22.07	23.47	24.04	23.27
M55-60X4042R	30.48	26.15	24.13	27.15	28.55	29.12	28.35
M55-60X5042R	36.83	32.50	30.48	33.50	34.90	35.47	34.70
M55-60X6842R	48.26	43.93	41.91	44.93	46.33	46.90	46.13
M55-60X8042R	55.88	51.55	49.53	52.55	53.95	54.52	53.75

NOTES:

- SEE ORDER CODE AND SHEET 5 FOR CONNECTOR HEIGHT AND CAP DETAILS. SEE SHEET 7 FOR RECOMMENDED PCB LAYOUTS.
- FOR TAPE AND REEL DETAILS, SEE SHEET 6.
- ALL TOLERANCES ARE ±0.20, UNLESS OTHERWISE STATED.
- FOR COMPLETE SPECIFICATION SEE COMPONENT SPECIFICATION C047XX (LATEST ISSUE).

HARWIN

www.harwin.com

TOLERANCES

X = ±1mm
X.X = ±0.50mm
X.XX = ±0.20mm
X.XXX = ±0.01mm
ANGLES = ±5°
UNLESS STATED

THIS DRAWING AND ANY INFORMATION OR DESCRIPTIVE MATTER SET OUT HEREON ARE CONFIDENTIAL AND COPYRIGHT PROPERTY OF THE HARWIN GROUP AND MUST NOT BE DISCLOSED, LOANED, COPIED OR USED FOR MANUFACTURING, TENDERING OR FOR ANY OTHER PURPOSE WITHOUT THEIR WRITTEN PERMISSION.

MATERIAL:

SEE ABOVE

TITLE:

1.27mm PITCH VERTICAL FEMALE CONNECTOR

DRAWING NUMBER:

M55-60XXX42R

SHT 4 OF 7

MGP	8	03.08.23	32860
NAME	ISS.	DATE	CN/CO
APPROVED: MGP			
CHECKED: AB			
DRAWN: M.PERREN			
ASSEMBLY DRG:			

Customer Information Sheet

IF IN DOUBT - ASK



NOT TO SCALE

THIRD ANGLE PROJECTION

ALL DIMENSIONS IN mm

CONNECTOR HEIGHT DETAILS

M55-600XX42R

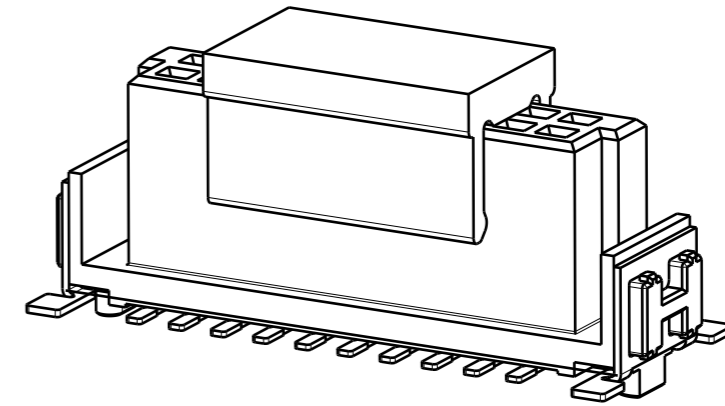
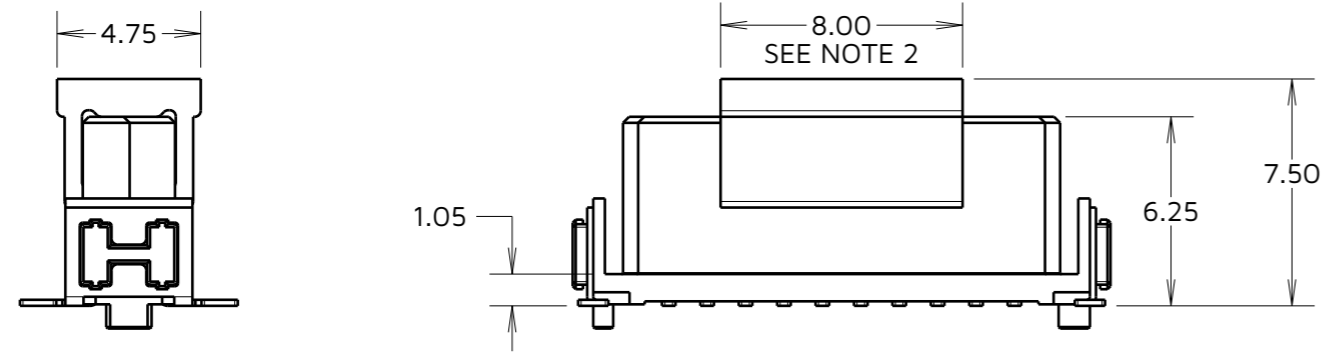

M55-601XX42R

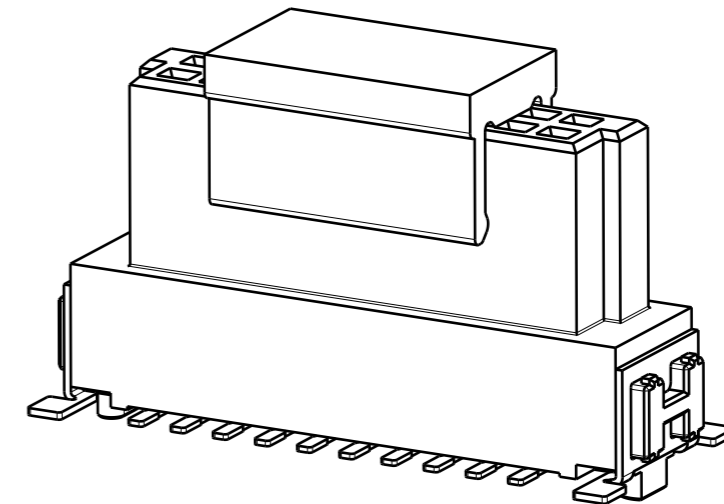
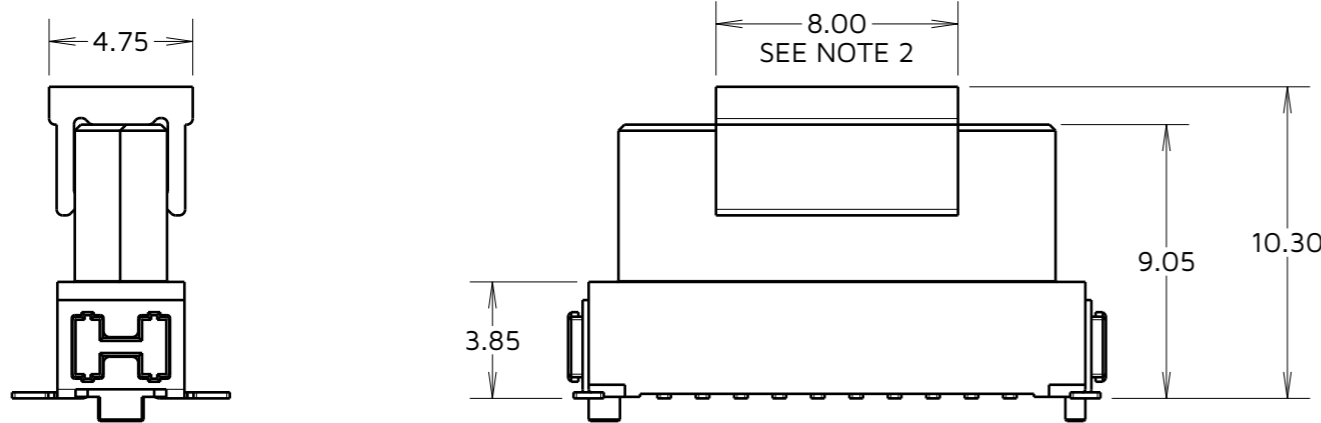

M55-602XX42R

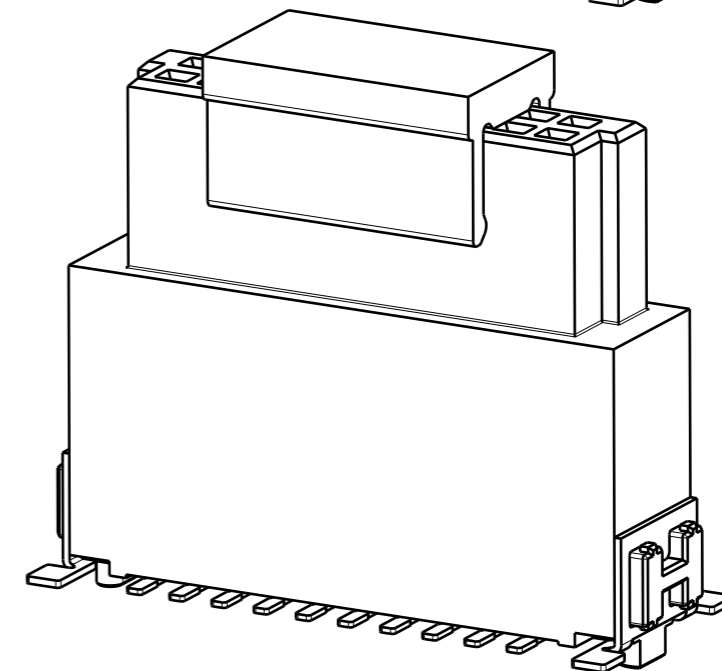
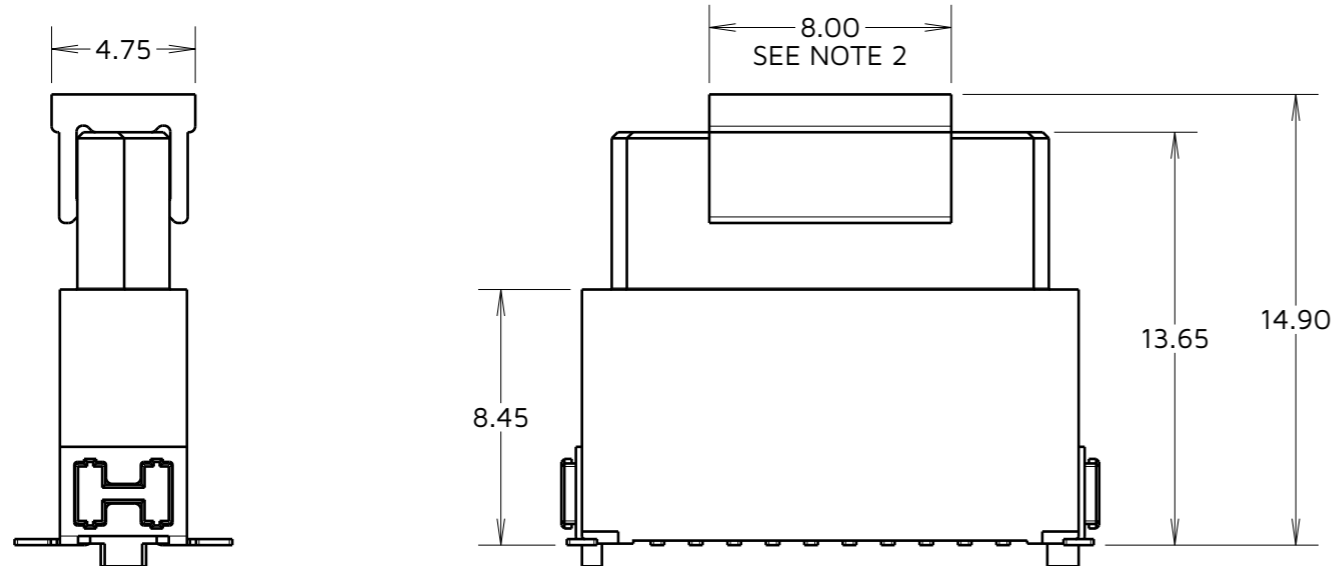

MGP	8	03.08.23	32860
NAME	ISS.	DATE	CN/CO
APPROVED: MGP			
CHECKED: AB			
DRAWN: M.PERREN			
ASSEMBLY DRG:			

- NOTES:
1. ALL TOLERANCES ARE ± 0.20 , UNLESS OTHERWISE STATED.
 2. PICK & PLACE CAP POSITIONED CENTRAL ± 1.6 mm TO MOULDING DIM 'A', SEE SHEET 4.

HARWIN

www.harwin.com

TOLERANCES
X. = ± 1 mm
X.X = ± 0.50 mm
X.XX = ± 0.20 mm
X.XXX = ± 0.01 mm
ANGLES = $\pm 5^\circ$
UNLESS STATED

THIS DRAWING AND ANY INFORMATION OR DESCRIPTIVE MATTER SET OUT HEREON ARE CONFIDENTIAL AND COPYRIGHT PROPERTY OF THE HARWIN GROUP AND MUST NOT BE DISCLOSED, LOANED, COPIED OR USED FOR MANUFACTURING, TENDERING OR FOR ANY OTHER PURPOSE WITHOUT THEIR WRITTEN PERMISSION.

MATERIAL:
SEE SHEET 4

TITLE:
1.27mm PITCH VERTICAL FEMALE CONNECTOR
DRAWING NUMBER:
M55-60XXX42R

Customer Information Sheet

IF IN DOUBT - ASK

©

NOT TO SCALE

THIRD ANGLE PROJECTION

ALL DIMENSIONS IN mm

TAPE DETAILS FOR
12 & 16 CONTACTS ONLY

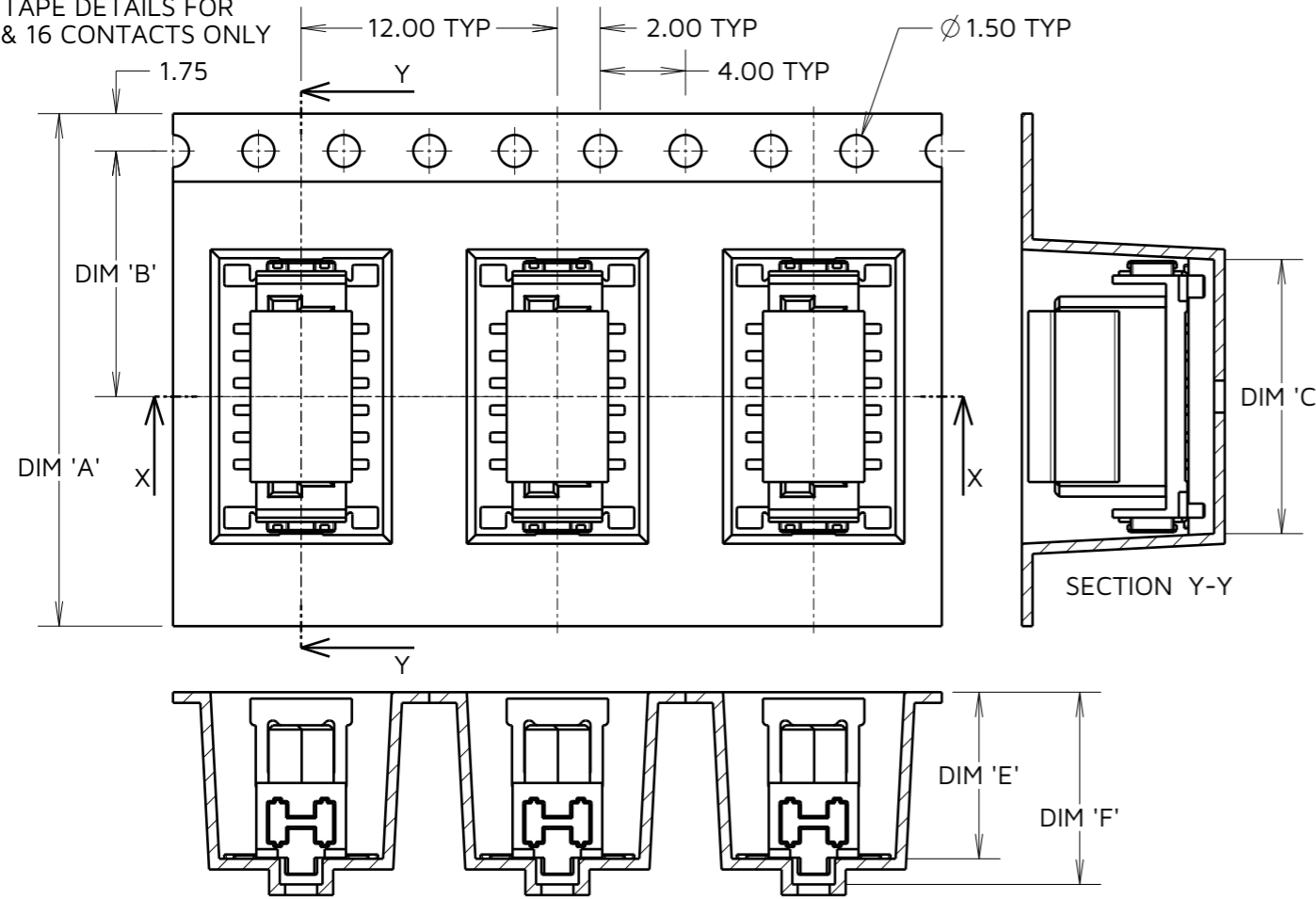

TAPE DETAILS FOR
20 TO 80 CONTACTS ONLY

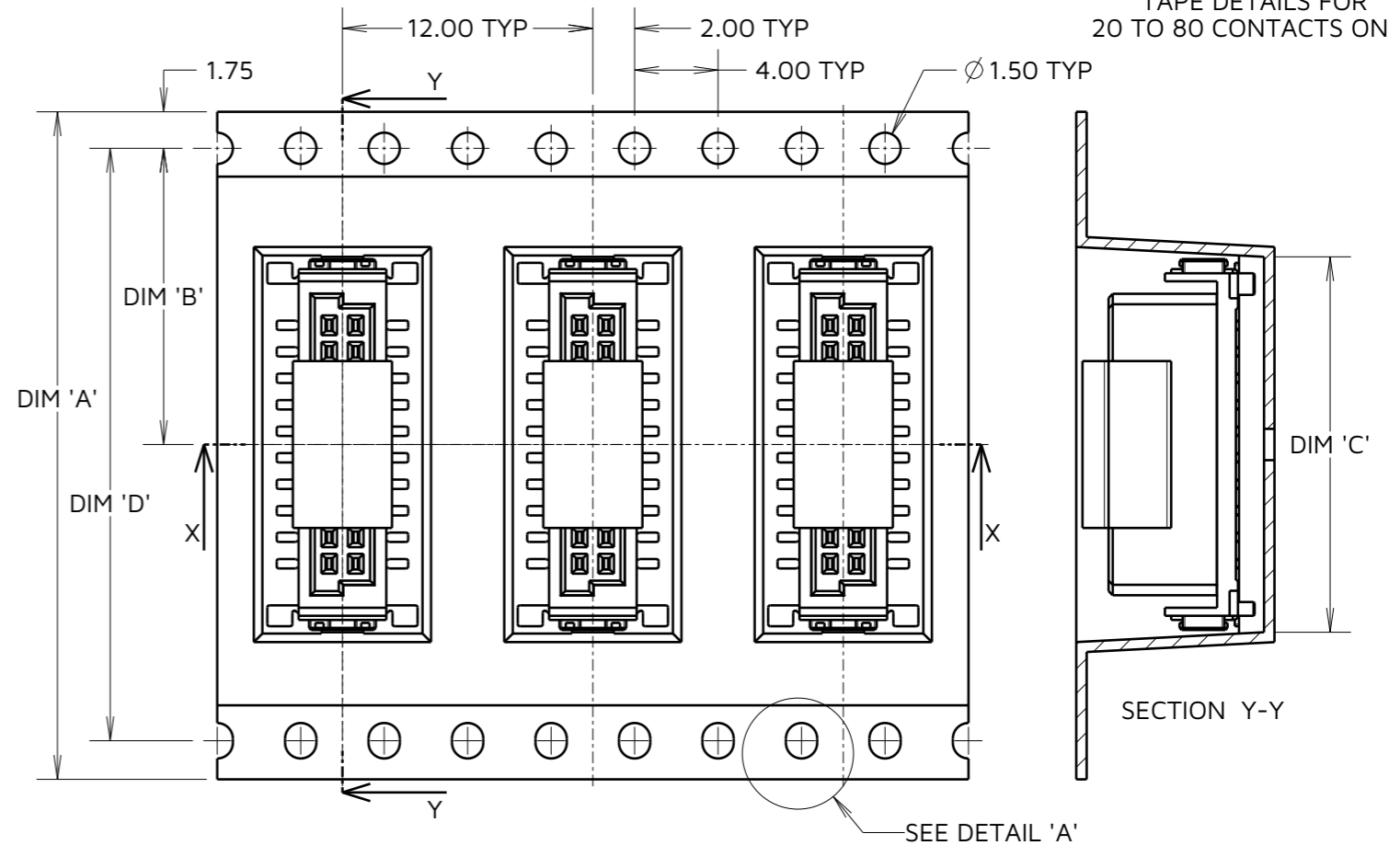

ORDER CODE: **M55-60XXX42R**

CONNECTOR HEIGHT:
 0 = 6.25
 1 = 9.05
 2 = 13.65

TOTAL No. OF CONTACTS:
 12, 16, 20, 26,
 32, 40, 50, 68, 80

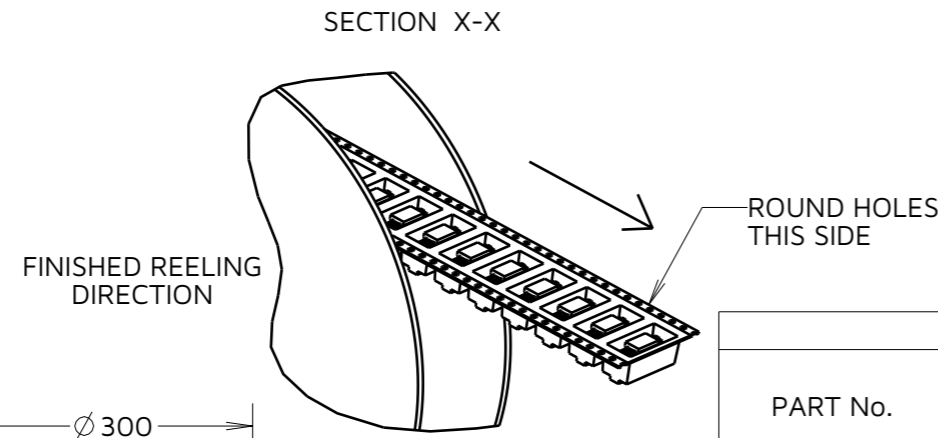
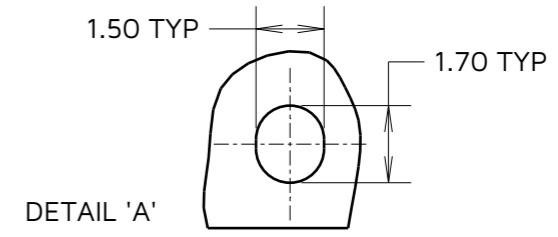

TABLE 1

PART No.	DIMENSION			
	DIM 'A' ±0.30	DIM 'B'	DIM 'C' ±0.15	DIM 'D'
M55-60X1242R	24.00	11.50	12.90	N/A
M55-60X1642R				
M55-60X2042R	32.00	14.20	18.00	28.40
M55-60X2642R				
M55-60X3242R	44.00	20.20	21.79	40.40
M55-60X4042R				
M55-60X5042R	56.00	26.20	37.03	52.40
M55-60X6842R				
M55-60X8042R	72.00	34.20	48.46 56.08	68.40

TABLE 2

PART No.	DIMENSION		PACK QTY
	DIM 'E'	DIM 'F'	
M55-600XX42R	7.8	9.0	550
M55-601XX42R	10.6	11.7	400
M55-602XX42R	15.2	16.4	200



NOTES:
 1. PRODUCT IS TAPE AND REELED IN GENERAL ACCORDANCE WITH EIA-481 (ELECTRONIC INDUSTRIES ASSOCIATION).
 2. FOR CONNECTOR DETAILS, SEE SHEET 4 & 5.

HARWIN
 www.harwin.com

TOLERANCES
 X. = ±1mm
 X.X = ±0.50mm
 X.XX = ±0.20mm
 X.XXX = ±0.01mm
 ANGLES = ±5°
 UNLESS STATED

THIS DRAWING AND ANY INFORMATION OR DESCRIPTIVE MATTER SET OUT HEREON ARE CONFIDENTIAL AND COPYRIGHT PROPERTY OF THE HARWIN GROUP AND MUST NOT BE DISCLOSED, LOANED, COPIED OR USED FOR MANUFACTURING, TENDERING OR FOR ANY OTHER PURPOSE WITHOUT THEIR WRITTEN PERMISSION.

MATERIAL:
 SEE SHEET 4

TITLE:
1.27mm PITCH VERTICAL FEMALE CONNECTOR
 DRAWING NUMBER:
M55-60XXX42R

MGP	8	03.08.23	32860
NAME	ISS.	DATE	CN/CO
APPROVED: MGP			
CHECKED: AB			
DRAWN: M.PERREN			
ASSEMBLY DRG:			

Customer Information Sheet

IF IN DOUBT - ASK

©

NOT TO SCALE

THIRD ANGLE PROJECTION

ALL DIMENSIONS IN mm

ROUND AND POLARIZED RECOMMENDED PCB LAYOUTS OPTIONS

RECOMMENDED ROUND HOLE PCB LAYOUT
TOLERANCE = ± 0.05

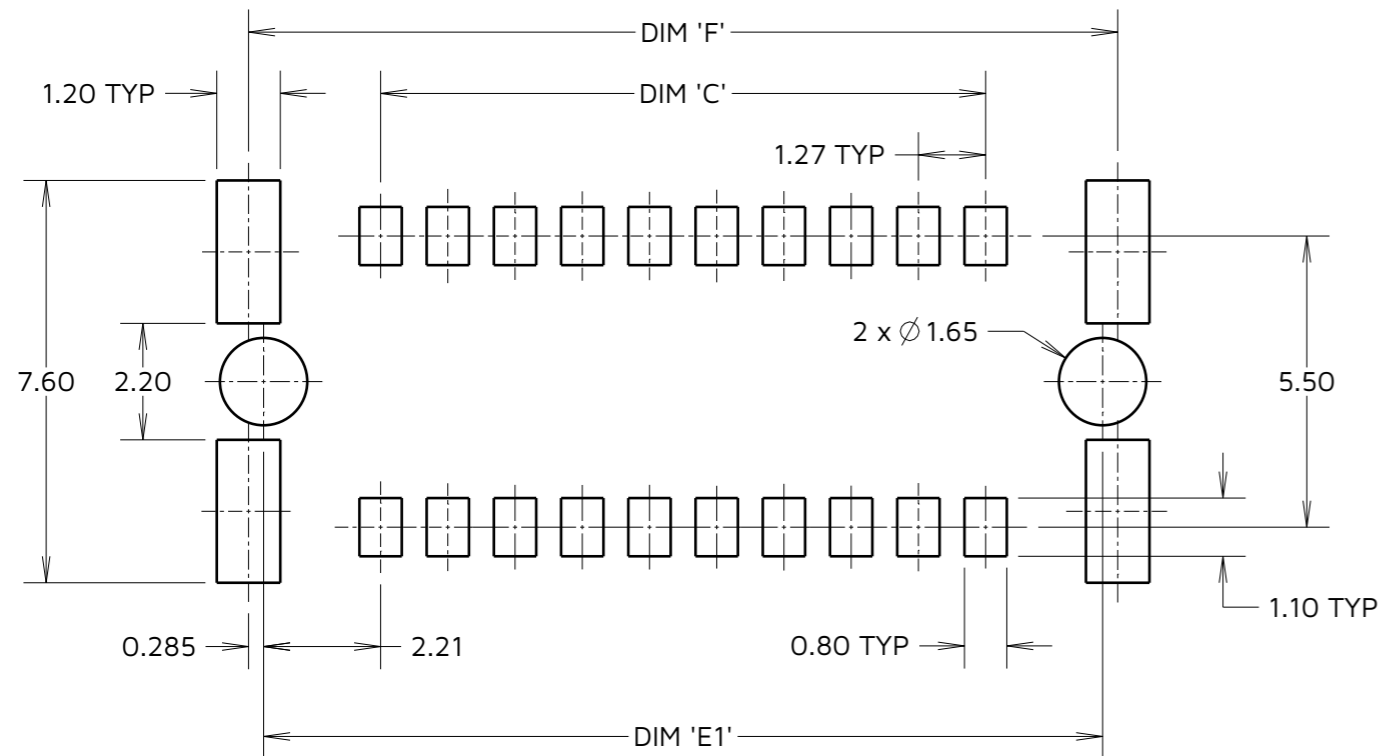

RECOMMENDED POLARIZED HOLE PCB LAYOUT
TOLERANCE = ± 0.05

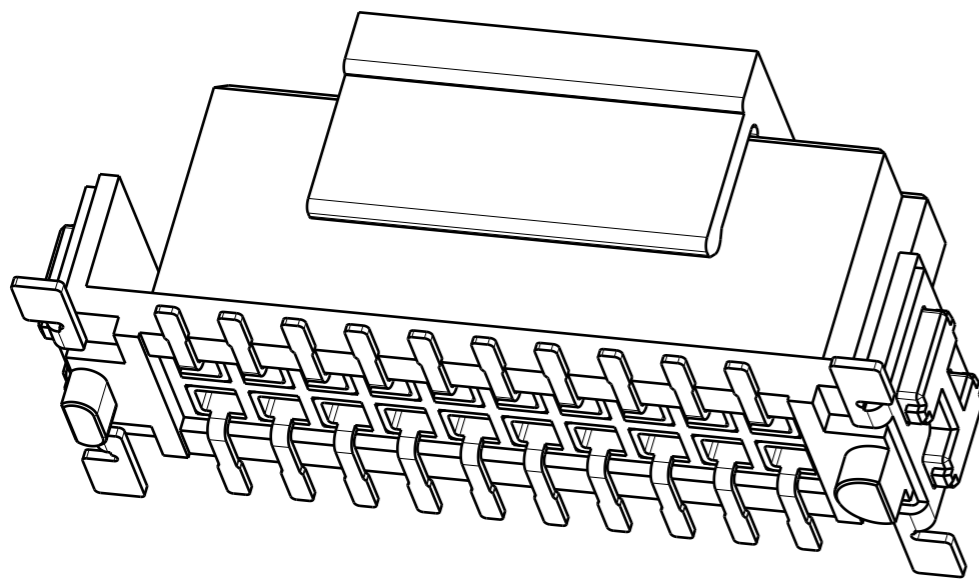
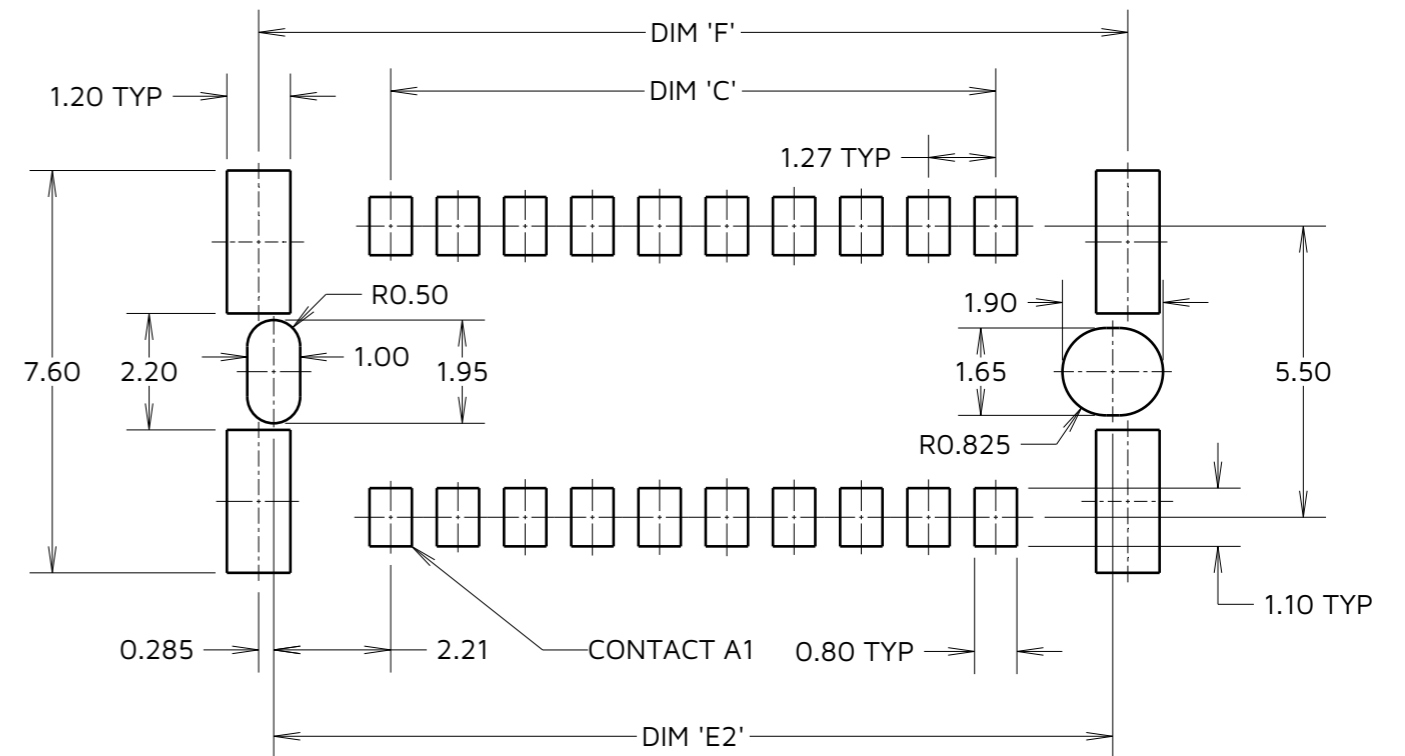

ORDER CODE:

M55-60XXX42R

CONNECTOR HEIGHT:

- 0 = 6.25
- 1 = 9.05
- 2 = 13.65

TOTAL No. OF CONTACTS:

- 12, 16, 20, 26,
- 32, 40, 50, 68, 80

PART No.	DIM 'C'	DIM 'E1'	DIM 'E2'	DIM 'F'
M55-60X1242R	6.35	10.77	10.70	11.34
M55-60X1642R	8.89	13.31	13.24	13.88
M55-60X2042R	11.43	15.85	15.78	16.42
M55-60X2642R	15.24	19.66	19.59	20.23
M55-60X3242R	19.05	23.47	23.40	24.04
M55-60X4042R	24.13	28.55	28.48	29.12
M55-60X5042R	30.48	34.90	34.83	35.47
M55-60X6842R	41.91	46.33	46.26	46.90
M55-60X8042R	49.53	53.95	53.88	54.52

MGP	8	03.08.23	32860
NAME	ISS.	DATE	CN/CO
APPROVED: MGP			
CHECKED: AB			
DRAWN: M.PERREN			
ASSEMBLY DRG:			

HARWIN

www.harwin.com

TOLERANCES
X. = $\pm 1\text{mm}$
X.X = $\pm 0.50\text{mm}$
X.XX = $\pm 0.20\text{mm}$
X.XXX = $\pm 0.01\text{mm}$
ANGLES = $\pm 5^\circ$
UNLESS STATED

THIS DRAWING AND ANY INFORMATION OR DESCRIPTIVE MATTER SET OUT HEREON ARE CONFIDENTIAL AND COPYRIGHT PROPERTY OF THE HARWIN GROUP AND MUST NOT BE DISCLOSED, LOANED, COPIED OR USED FOR MANUFACTURING, TENDERING OR FOR ANY OTHER PURPOSE WITHOUT THEIR WRITTEN PERMISSION.

MATERIAL:

SEE SHEET 4

TITLE:

1.27mm PITCH VERTICAL FEMALE CONNECTOR

DRAWING NUMBER:

M55-60XXX42R

SHT
7
OF
7