

# HC860

## HC860 Dual-Purpose Dual-Band GNSS + Active Iridium Helical Antenna

Frequency Coverage: GNSS/QZSS-L1/L2, GLONASS-G1/G2, Galileo-E1, BeiDou-B1 + Active Iridium

The dual-purpose (GNSS and Iridium signal reception) HC860 helical antenna is designed for precision positioning, covering the GPS/QZSS-L1/L2, GLONASS-G1/G2, Galileo-E1, and BeiDou-B1 frequency bands, including the satellite-based augmentation system (SBAS) available in the region of operation [WAAS (North America), EGNOS (Europe), MSAS (Japan), or GAGAN (India)] and for active Iridium signal reception. The HC860 also supports active Iridium<sup>®</sup> reception in the 1616.0-1626.5 MHz band.

Weighing only 42 g, the light and compact HC860 features a precision-tuned helix element that provides excellent axial ratios and operates without the requirement of a ground plane, making it ideal for many applications, including autonomous vehicle navigation (land, sea, and air), handheld land survey devices, automotive positioning, timing and other precise positioning applications

The HC860 features an industry-leading low current, low-noise amplifier (LNA) that includes an integrated low-loss pre-filter to prevent harmonic interference from high-amplitude signals, such as 700 MHz band LTE and other nearby in-band cellular signals.

Tallysman's helical family has passed a rigorous 30-hour vibration test procedure, consisting of five cycles of 2-hour tests per axis (x, y, z):

- Cycle 1: 1.05 Grms;
- Cycle 2: 1.20 Grms;
- Cycle 3: 1.35 Grms;
- Cycle 4: 3.67 Grms;
- Cycle 5: 3.67 Grms.

All Tallysman housed helical antenna elements are protected by a robust military-grade IP67-compliant plastic enclosure. The enclosure's base provides three threaded inserts for secure attachment, as well as a rubber O-ring around the outer edge to seal the antenna base and its integrated male SMA connector.

For mounting instructions, visit:

[https://www.tallysman.com/downloads/Helical\\_Mounting\\_Instruction.pdf](https://www.tallysman.com/downloads/Helical_Mounting_Instruction.pdf)



### Applications

- Iridium<sup>®</sup> data applications
- Autonomous unmanned aerial vehicles (UAVs)
- Precision GNSS positioning
- Precision land survey positioning
- Mission-critical GNSS timing
- Network timing and synchronization
- Sea and land container tracking
- Fleet management and asset tracking
- Marine and avionics systems
- Law enforcement and public safety

### Features

- Low noise preamp (1.7 dB typ.)
- Axial ratio ( $\leq 0.5$  dB at zenith)
- LNA gain (28 dB typ. | 35 dB typ.)
- Low current (15 mA typ. [28 dB] | 21 mA typ. [35 dB])
- ESD circuit protection (15 kV)
- Invariant performance from 2.5 to 12 VDC
- IP67, REACH, and RoHS compliant

### Benefits

- Extremely light (42 g)
- Ideal for RTK and PPP surveying systems
- Excellent RH circular polarized signal reception
- Great multipath rejection
- Increased system accuracy
- Excellent signal-to-noise ratio
- Industrial temperature range
- Rugged design, ideal for harsh environments

**About Tallysman:** With global headquarters and manufacturing in Ottawa, Canada, Tallysman is a leading manufacturer of high-precision antennas and components for Global Navigation Satellite System (GNSS) applications. Tallysman's mission is to support the needs of a new generation of positioning systems by delivering unprecedented antenna precision at competitive prices. Learn more at [www.tallysman.com](http://www.tallysman.com)

Revision: 1.1

**Contact us:**  
[info@tallysman.com](mailto:info@tallysman.com)  
T: +1 613 591-3131

# HC860 Dual-Purpose Dual-Band GNSS + Active Iridium Helical Antenna

Frequency Coverage: GNSS/QZSS-L1/L2, GLONASS-G1/G2, Galileo-E1, BeiDou-B1 + Active Iridium

Antenna			
Technology		Dual-frequency, RHCP quadrifilar helix	
		Gain	Axial Ratio
		dBic typ. at Zenith	dB at Zenith
GNSS			
GPS / QZSS	L1	2.2	≤ 0.5
	L2	2.4	≤ 0.5
	L5	-	-
GLONASS	G1	2.6	≤ 0.5
	G2	2.1	≤ 0.5
	G3	-	-
Galileo	E1	2.2	≤ 0.5
	E5a	-	-
	E5b	-	-
	E6	-	-
BeiDou	B1	2.2	≤ 0.5
	B2	-	-
	B2a	-	-
	B3	-	-
IRNSS / NavIC	L5	-	-
QZSS	L6	-	-
L-band correction services		-	-
Satellite Communications			
Iridium		2.5	≤ 0.5
Globalstar		-	-
Phase Centre			
Phase Centre Variation (PCV)		± 3.0 mm (all freq.)	
Phase Centre Offset (PCO)		30 mm @ L1   35 mm @ L2	

Mechanicals	
Mechanical Size	44.2 mm (dia.) x 62.4 mm (h.)
Weight	42 g
Available Connectors	SMA (male)
Radome / Enclosure	Radome and Base: EXL9330
Mount	3x M2.5 screws

Environmental	
Operating Temperature	-45 °C to +85 °C
Storage Temperature	-55 °C to +95 °C
Random Vibration	MIL-STD-810E - Test method 514.5 4 hours per axis (x, y, z) at 3.674 Grms
Shock and Drop	-
Salt Fog	-
IP Rating (housing)	IP67
Compliance	IPC-A-610, FCC, RED / CE Mark, RoHS, REACH

Warranty:	
Parts and Labour	3-year standard warranty

## Low Noise Amplifier (LNA) - Measured at 3.0 VDC and 25°C

Frequency Bandwidth	Out-of-Band Rejection
Lower Band	1217 - 1255 MHz > 43 dB @ < 1100 MHz > 30 dB @ < 1200 MHz > 32 dB @ > 1300 MHz
Upper Band	1559 - 1626.5 MHz > 26 dB @ ≤ 1450 MHz > 50 dB @ ≥ 1700 MHz

Architecture	Pre-filter → LNA
Gain	28 dB typ.   35 dB typ.
Noise Figure	1.7 dB typ.
VSWR	< 1.5:1 typ.   2.0:1 max.
Supply Voltage Range	2.5 to 12 VDC
Supply Current	15 mA typ. (28 dB)   21 mA typ. (35 dB)
ESD Circuit Protection	15 kV air discharge
P 1dB Output	10 dBm @ L1
Group Delay Variation	15 ns @ L1   12 ns @ L2

## Mechanical Diagram

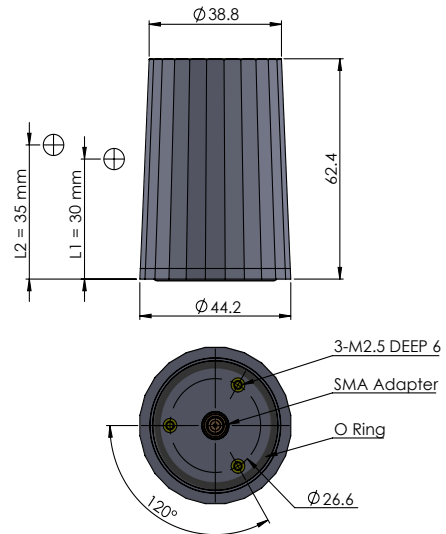

## Ordering Information

Part Number **33-HC860-xx**

where xx = gain (28 or 35 dB)

Please refer to our **Ordering Guide** to review available radomes and connectors at: <https://www.tallysman.com/resource/tallysman-ordering-guide/>