

Verpackt im Gurt in Anlehnung an DIN IEC 60286-3  
 tape on reel packaging according to DIN IEC 60286-3  
 Verpackungseinheit: 400 Stück  
 packaging unit: 400 pcs

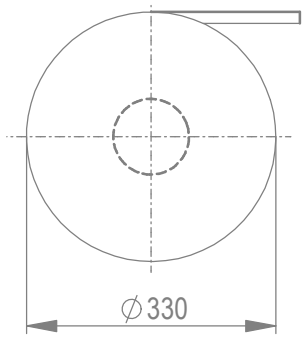

Abspulrichtung - reel off direction

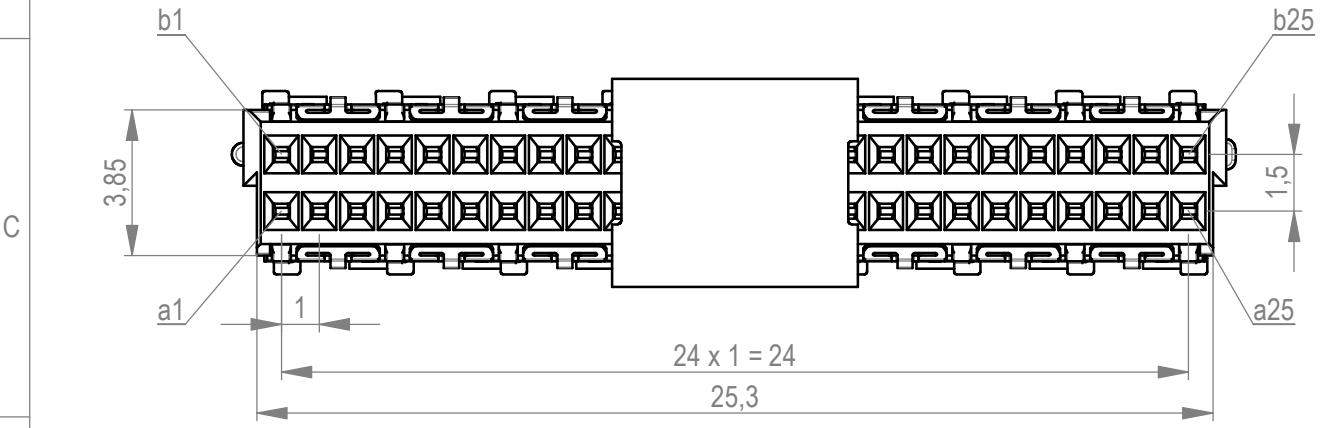

Anforderungsstufe 1  
 performance level 1  
 Kontaktbereich vergoldet  
 mating area gold plating  
 Anschlussbereich verzinkt 4-6 µm  
 terminal area 4-6 µm tin plating  
 Koplanarität der Anschlüsse ≤ 0,1 mm  
 coplanarity area of termination ≤ 0,1 mm

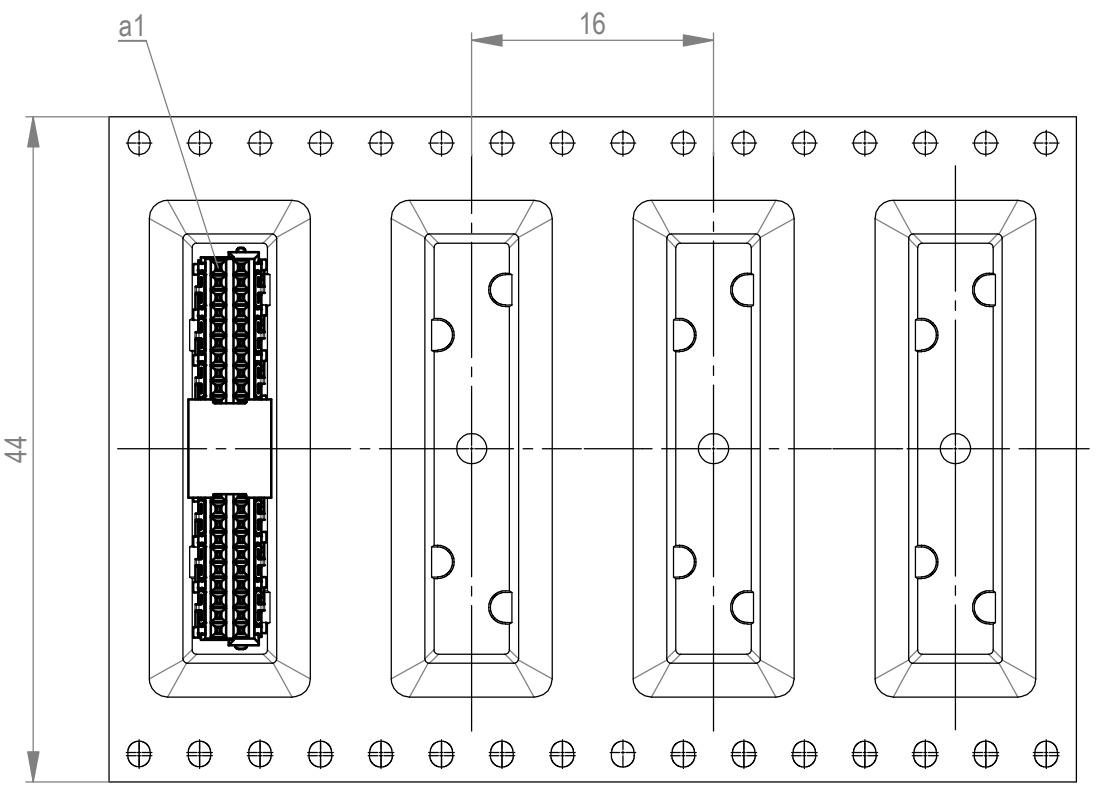

Leiterplatten-Layout Vorschlag / PCB-Layout Proposal

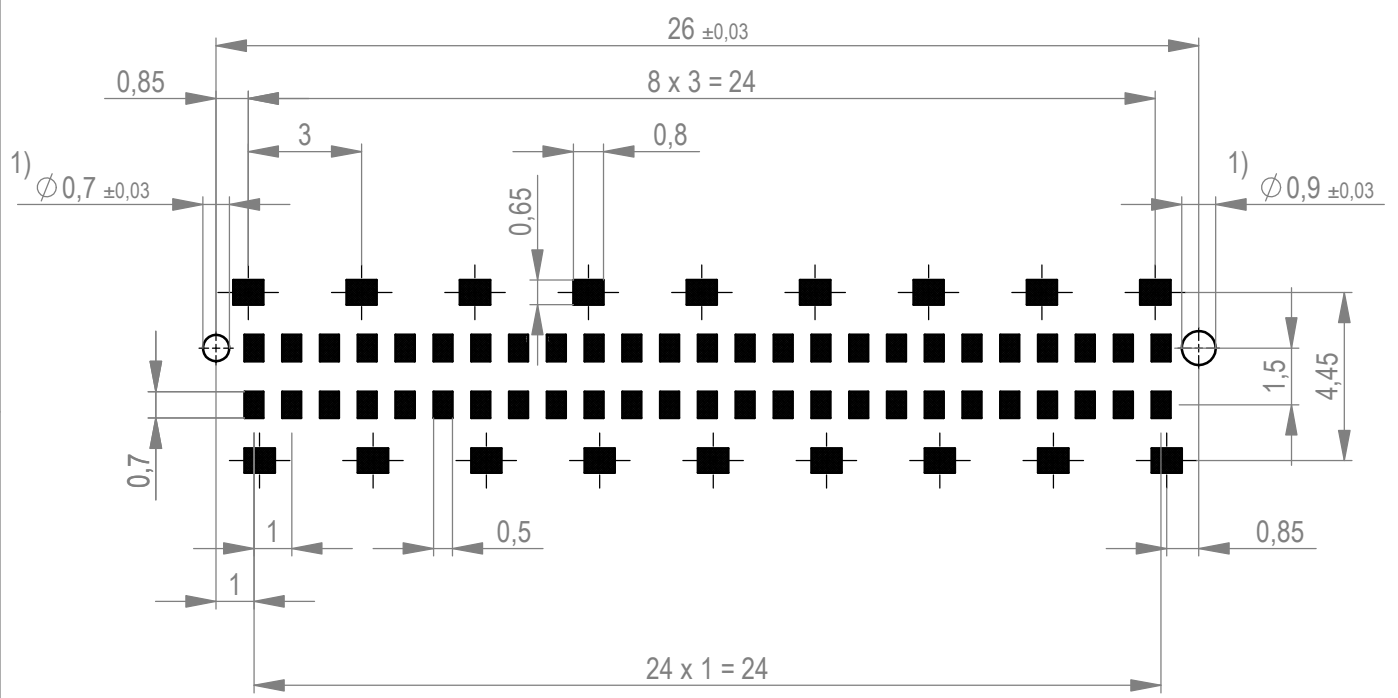

1) Durchmesser des Bohrers / Drill tool

Weitergabe sowie Vervielfältigung dieses Dokuments, Verwertung und Mitteilung seines Inhalts sind verboten, soweit nicht ausdrücklich gestattet. Zuwiderhandlungen verpflichten zu Schadenersatz. Alle Rechte für den Fall der Patent-, Gebrauchsmuster- oder Geschmacksmustererhaltung vorbehalten. The reproduction, distribution and utilization of this document as well as the communication of its contents to others without express authorization is prohibited. Offenders will be held liable for the payment of damages. All rights reserved in the event of the grant of a patent, utility model or design.

Die deutsche Version dieser Zeichnung dient nur zur Erleichterung der Handhabung. Bei Abweichungen von dem englischen Original gilt das englische Original. The german version of this drawing has been offered for convenience only and may deviate from the english original. In case of any deviation the English version shall prevail.

Dimension no.	Tolerances		Scale	5:1
	ISO 8015	All Dimensions in mm	Material	
Customer drawing:	This Drawing is a controlled Document.		Subject to modification without prior notice. Drawing will not be updated.	
e1	18.05.2023			Federleiste 6mm SMD, 50 polig Female 6mm SMD, 50 contacts
Index	Date			
			Class	MSPEED
				A3