

### DESCRIPTION

The MPQ6400 is a microprocessor ( $\mu\text{P}$ ) supervisory circuit which can monitor and provide a reset function for system voltages from 0.4V. When either the SENSE voltage falls below its threshold ( $V_{IT}$ ) or the voltage of manual reset ( $\overline{\text{MR}}$ ) is pulled to a logic low, the RESET signal will be asserted. Fixed voltage threshold options set by the factory are available for standard voltage rails between 0.9V and 5V, while the MPQ6400DG(J)-01 allows for an adjustable voltage threshold with an external resistor divider. When the SENSE voltage and  $\overline{\text{MR}}$  exceed their respective thresholds, RESET is pulled up to logic high after a user-programmable delay time.

The MPQ6400 has a very low quiescent current of  $1.6\mu\text{A}$  typically, which makes it ideal suitable for battery-powered applications. The device features a precision reference to achieve  $\pm 1\%$  threshold accuracy. The reset delay time is set by an external capacitor connected between  $C_{\text{DELAY}}$  and GND, allowing the user to select any delay time between 2.1ms and 10s. The 380ms delay time is set by connecting the  $C_{\text{DELAY}}$  pin to  $V_{\text{CC}}$ . The 24ms delay time is set by floating the  $C_{\text{DELAY}}$  pin. The MPQ6400 is available in QFN-6 (2mmx2mm) and TSOT23-6 packages.

### FEATURES

- Fixed Voltage Threshold from 0.9V to 5V
- Adjustable Voltage Threshold from 0.4V
- Low Quiescent Current:  $1.6\mu\text{A}$  (Typ)
- Adjustable Reset Delay Time: 2.1ms to 10s
- High Threshold Accuracy:  $\pm 1\%$  (Typ)
- Manual Reset ( $\overline{\text{MR}}$ ) Input
- Open-Drain RESET Output
- Immune to Short Negative SENSE Voltage
- Guaranteed Reset Valid to  $V_{\text{CC}}=0.8\text{V}$
- Available in QFN-6 (2mmx2mm) and TSOT23-6 Packages
- Available in AEC-Q100 Qualified

### APPLICATIONS

- Advanced Driver Assistance Systems (ADAS)
- Body Control Modules
- Infotainment Systems
- Low Quiescent Current Systems
- Electric Vehicles
- MCU/DSP/FPGA/ASIC Applications

All MPS parts are lead-free, halogen-free, and adhere to the RoHS directive. For MPS green status, please visit the MPS website under Quality Assurance. "MPS", the MPS logo, and "Simple, Easy Solutions" are trademarks of Monolithic Power Systems, Inc. or its subsidiaries.

### TYPICAL APPLICATION

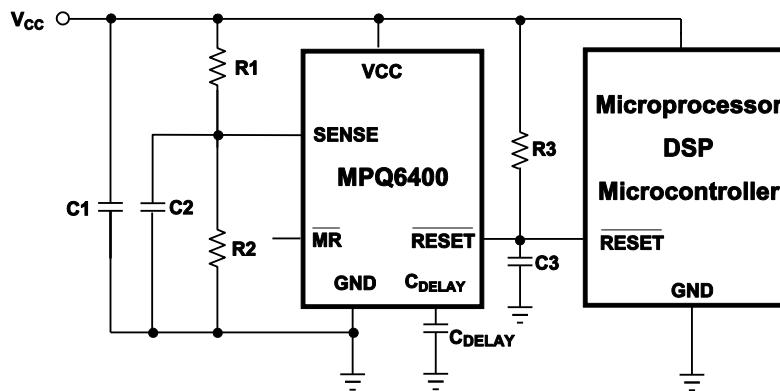

### ORDERING INFORMATION

Part Number*	Package	T <sub>J</sub>	Top Marking	MSL Rating***
MPQ6400DG-33**	QFN-6 (2x2mm)	-40°C to +125°C	See Below	1
MPQ6400DG-33-AEC1	QFN-6 (2x2mm)	-40°C to +125°C		
MPQ6400DG-01	QFN-6 (2x2mm)	-40°C to +125°C		
MPQ6400DG-01-AEC1	QFN-6 (2x2mm)	-40°C to +125°C		
MPQ6400DJ-33-AEC1	TSOT23-6	-40°C to +125°C		
MPQ6400DJ-01-AEC1	TSOT23-6	-40°C to +125°C		

\*For Tape & Reel, add suffix -Z (e.g. MPQ6400DG-XX-Z);  
 For RoHS compliant packaging, add suffix -LF (e.g. MPQ6400DG-XX-LF-Z).

\*\* Check factory for availability in other options.

\*\*\* Moisture Sensitivity Level Rating

#### TOP MARKING

9RY  
 LLL

9R: Product code of MPQ6400DG-33/MPQ6400DG-33-AEC1  
 Y: Year code  
 LLL: Lot number

#### TOP MARKING

5BY  
 LLL

5B: Product code of MPQ6400DG-01/MPQ6400DG-01-AEC1  
 Y: Year code  
 LLL: Lot number

#### TOP MARKING

| 3SYW

3S: Product code of MPQ6400DJ-33-AEC1  
 Y: Year code  
 W: week code

## TOP MARKING

| 4BYW

4B: Product code of MPQ6400DJ-01-AEC1

Y: Year code

W: week code

## PACKAGE REFERENCE

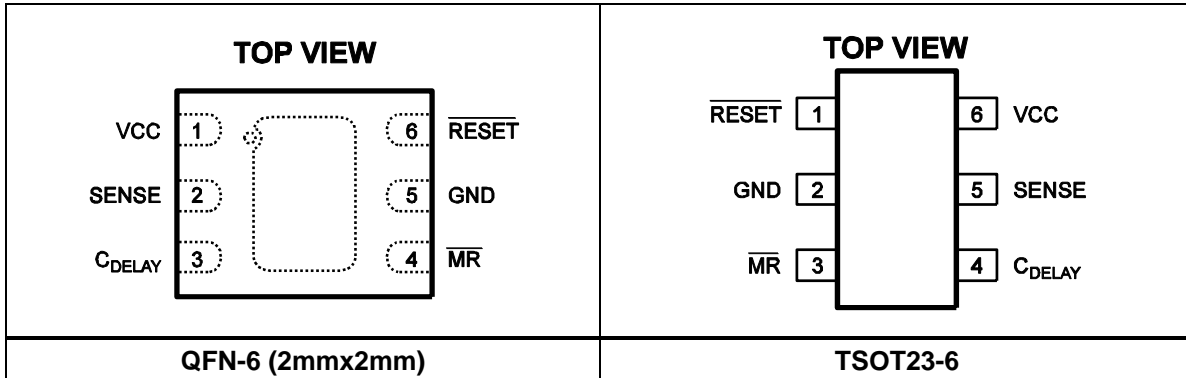

**ABSOLUTE MAXIMUM RATINGS** <sup>(1)</sup>

Supply voltage ( $V_{CC}$ ).....	-0.3 to +6V
$C_{DELAY}$ voltage ( $V_{CDELAY}$ ) .....	-0.3V to $V_{CC} + 0.3V$
SENSE voltage ( $V_{SENSE}$ ) .....	-0.3V to 6V
All other pins.....	-0.3V to +6V
RESET current ( $I_{RESET}$ ) .....	5mA
Continuous power dissipation ( $T_A = 25^\circ C$ ) <sup>(2)</sup>	
QFN-6 (2mmx2mm).....	2.5W
TSOT23-6 .....	0.75W
Junction temperature.....	150°C
Lead temperature .....	260°C
Storage temperature.....	-65°C to +150°C

**ESD Ratings**

Human body mode (HBM):

$C_{DELAY}$ to $V_{CC}$ .....	Class 1C <sup>(3)</sup>
All other pins.....	Class 2 <sup>(3)</sup>
Charged device mode (CDM) .....	Class C2b <sup>(4)</sup>

**Recommended Operating Conditions**

Supply voltage ( $V_{CC}$ ).....	1.8V to 5.5V
Maximum junction temp ( $T_J$ ) .....	+125°C <sup>(5)</sup>

**Thermal Resistance** <sup>(6)</sup>

	$\theta_{JA}$	$\theta_{JC}$
QFN-6 (2mmx2mm) .....	50	12 ... °C/W
TSOT23-6 .....	220	110 .. °C/W

**Notes:**

- 1) Exceeding these ratings may damage the device.
- 2) The maximum allowable power dissipation is a function of the maximum junction temperature,  $T_J (MAX)$ , the junction-to-ambient thermal resistance,  $\theta_{JA}$ , and the ambient temperature,  $T_A$ . The maximum allowable continuous power dissipation at any ambient temperature is calculated by  $P_D(MAX) = (T_J (MAX) - T_A) / \theta_{JA}$ . Exceeding the maximum allowable power dissipation will cause excessive die temperature, and the regulator will go into thermal shutdown. Internal thermal shutdown circuitry protects the device from permanent damage.
- 3) Per AEC-Q100-002.
- 4) Per AEC-Q100-011.
- 5) Operating devices at junction temperatures greater than 125°C is possible, please contact MPS for details.
- 6) The value of  $\theta_{JA}$  given in this table is only valid for comparison with other packages and cannot be used for design purposes. These values were calculated in accordance with JESD51-7, and simulated on a specified JEDEC board. They do not represent the performance obtained in an actual application.

## ELECTRICAL CHARACTERISTICS

1.8V ≤ V<sub>CC</sub> ≤ 5.5V, R<sub>3</sub> = 100kΩ, C<sub>3</sub> = 47pF, T<sub>J</sub> = -40°C to +125°C, Typical values are at T<sub>J</sub> = +25°C, unless otherwise noted.

Parameters	Symbol	Condition	Min	Typ	Max	Units
Input Supply Range	V <sub>CC</sub>		1.8		5.5	V
Supply Current (current into V <sub>CC</sub> pin)	I <sub>CC</sub>	V <sub>CC</sub> = 3.3V, $\overline{\text{RESET}}$ not asserted. $\overline{\text{MR}}$ , $\overline{\text{RESET}}$ , C <sub>DELAY</sub> open		1.6	5	μA
		V <sub>CC</sub> = 5.5V, $\overline{\text{RESET}}$ not asserted. $\overline{\text{MR}}$ , $\overline{\text{RESET}}$ , C <sub>DELAY</sub> open		1.85	15	μA
Low-level Output Voltage	V <sub>OL</sub>	1.3V ≤ V <sub>CC</sub> < 1.8V, I <sub>OL</sub> = 0.4mA			0.3	V
		1.8V ≤ V <sub>CC</sub> ≤ 5.5V, I <sub>OL</sub> = 1.0mA			0.4	V
Power-up Reset Voltage <sup>(7)</sup>		V <sub>OL</sub> (max) = 0.2V, I <sub>RESET</sub> = 15μA, T <sub>rise(V<sub>CC</sub>)</sub> ≥ 15μs/V			0.8	V
Negative-going Input Threshold Accuracy <sup>(9)</sup>	V <sub>IT</sub>		-3	1	1.7	%
Hysteresis on V <sub>IT</sub> Pin	V <sub>HYS</sub>			1.5	4	V <sub>IT</sub> %
$\overline{\text{MR}}$ Internal Pull-up Resistance	R <sub>MR</sub>		50	110		kΩ
Input Current at SENSE Pin	I <sub>SENSE</sub>	MPQ6400-33, V <sub>SENSE</sub> = 6V		2.4		μA
		MPQ6400-01, V <sub>SENSE</sub> = 6V			100	nA
$\overline{\text{RESET}}$ Leakage Current		V <sub>RESET</sub> = 5.5V, $\overline{\text{RESET}}$ not asserted			2	μA
$\overline{\text{MR}}$ Logic Low Input	V <sub>IL</sub>				0.25V <sub>CC</sub>	V
$\overline{\text{MR}}$ Logic High Input	V <sub>IH</sub>		0.7V <sub>CC</sub>			V
SENSE Maximum Transient Duration	t <sub>w</sub>	V <sub>IH</sub> = 1.05 V <sub>IT</sub> , V <sub>IL</sub> = 0.95 V <sub>IT</sub>		17.5		μs
$\overline{\text{RESET}}$ Delay Time	t <sub>d</sub>	C <sub>DELAY</sub> = Open	15	24	34	ms
		C <sub>DELAY</sub> = V <sub>CC</sub> <sup>(8)</sup>	230	380	530	ms
		C <sub>DELAY</sub> = 150pF	1.3	2.1	3	ms
		C <sub>DELAY</sub> = 10nF <sup>(8)</sup>	61	102	142	ms
$\overline{\text{MR}}$ to $\overline{\text{RESET}}$ Propagation Delay	t <sub>pHL1</sub>	V <sub>IH</sub> = 0.7 V <sub>CC</sub> , V <sub>IL</sub> = 0.25 V <sub>CC</sub>		160		ns
High to Low Level $\overline{\text{RESET}}$ Delay, SENSE to $\overline{\text{RESET}}$	t <sub>pHL2</sub>	V <sub>IH</sub> = 1.05 V <sub>IT</sub> , V <sub>IL</sub> = 0.95 V <sub>IT</sub>		17.5		μs

**Note:**

- 7) The lowest supply voltage (V<sub>CC</sub>) at which  $\overline{\text{RESET}}$  becomes active.  
 8) Not tested in production and guaranteed by design and characterization.  
 9) V<sub>SENSE</sub> Falling Slowly

## ORDERING INFORMATION

Product	Package	Top Marking	Nominal Supply Voltage	Threshold Voltage (VIT)
MPQ6400DG-33	QFN	9R	3.3V	3.07V
MPQ6400DG-01	QFN	5B	3.3V	Adjustable
MPQ6400DJ-33	TSOT23-6	3S	3.3V	3.07V
MPQ6400DJ-01	TSOT23-6	4B	3.3V	Adjustable

## PIN FUNCTIONS

Pin #		Name	Description
QFN-6	TSOT23-6		
1	6	V <sub>CC</sub>	Supply voltage. A 0.1uF decoupling ceramic capacitor should be put close to this pin.
2	5	SENSE	SENSE pin is connected to the monitored system voltage. When the monitored voltage is below desired threshold, $\overline{\text{RESET}}$ is asserted.
3	4	C <sub>DELAY</sub>	Programmable reset delay time pin. When C <sub>DELAY</sub> connected to V <sub>CC</sub> through a resistor between 50kΩ and 200kΩ, a 380ms delay time is selected. When C <sub>DELAY</sub> floated, the delay time is 24ms. A capacitor bigger than 150pF connected C <sub>DELAY</sub> to GND could be used to get the user's programmable time from 2.1ms to 10s.
4	3	$\overline{\text{MR}}$	The manual reset ( $\overline{\text{MR}}$ ) can introduce another logic signal to control the $\overline{\text{RESET}}$ . It is internally connected to V <sub>CC</sub> through a 90kΩ resistor.
5	2	GND	Ground.
6	1	$\overline{\text{RESET}}$	$\overline{\text{RESET}}$ is an open drain signal which will be asserted when the SENSE voltage drops below a preset threshold or when the manual reset ( $\overline{\text{MR}}$ ) pin drops to a logic low. The $\overline{\text{RESET}}$ delay time is programmable from 2.1ms to 10s by using external capacitors. A pull-up resistor bigger than 10k should be connected this pin to supply line, and the $\overline{\text{RESET}}$ outputting a higher voltage than V <sub>CC</sub> is allowable.

## DETAIL DESCRIPTION

The MPQ6400 product family asserts a  $\overline{\text{RESET}}$  signal when either the SENSE pin voltage is lower than V<sub>IT</sub> or the manual reset ( $\overline{\text{MR}}$ ) is driven low. The MPQ6400-XX family, other than the MPQ6400DG(J)-01, can monitor a fixed voltage from 0.9V to 5.0V. The MPQ6400DG(J)-01 can monitor any voltage above 0.4V by adjusting the external resistor divider. After both the manual reset ( $\overline{\text{MR}}$ ) and SENSE voltages exceed their thresholds, the

$\overline{\text{RESET}}$  output remains asserted for a user's programmable delay time. Two fixed  $\overline{\text{RESET}}$  delay times are user-selectable: 380ms delay time by connecting the C<sub>DELAY</sub> pin to V<sub>CC</sub>, and 24ms delay time by leaving the C<sub>DELAY</sub> pin float. Any delay time from 2.1ms to 10s could be gotten by connecting a capacitor between C<sub>DELAY</sub> and GND. The wide monitor voltage and programmable reset delay time make MPQ6400 product family suitable for a broad array of applications.

## TYPICAL PERFORMANCE CHARACTERISTICS

$V_{CC}=3.3V$ ,  $R_3 = 100k\Omega$ ,  $C_3 = 47pF$ ,  $T_A = -40^\circ C$  to  $+125^\circ C$ , Typical values are at  $T_A=+25^\circ C$ , unless otherwise noted.

**Supply Current vs.  $V_{CC}$**

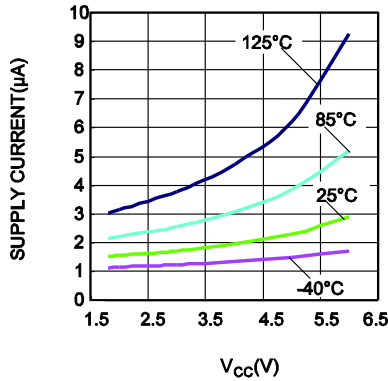

**Reset Delay Time vs.  $C_{DELAY}$**

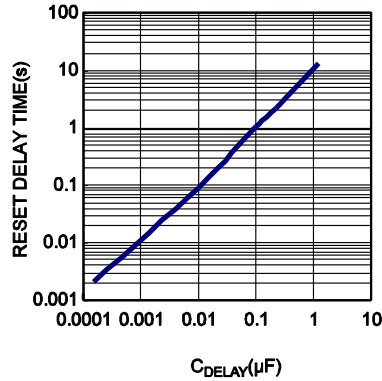

**Maximum SENSE Transient Duration vs. SENSE Threshold Overdrive Voltage**

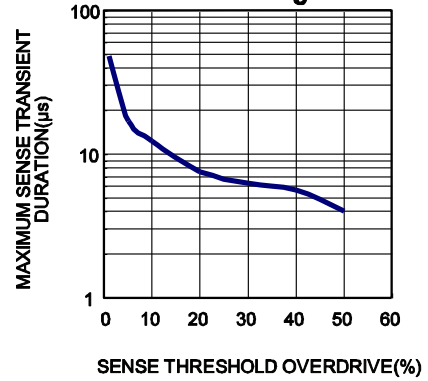

**Reset Delay vs. Temperature ( $C_{DELAY}=open$ )**

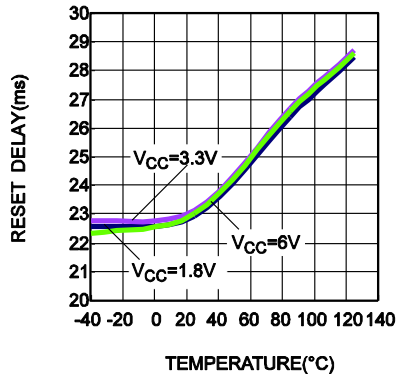

**Reset Delay vs. Temperature ( $C_{DELAY}=V_{CC}$ )**

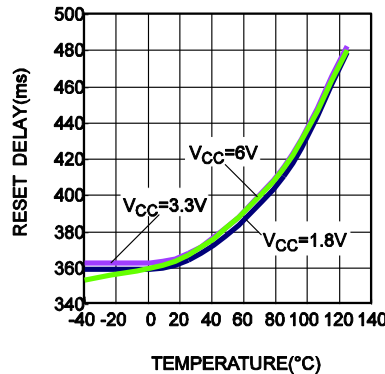

**Reset Delay vs. Temperature ( $C_{DELAY}=150pF$  Cap)**

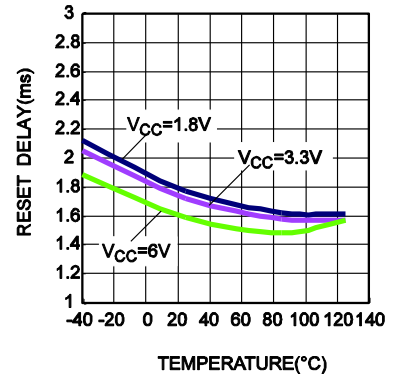

**Normalized  $V_{IT}$  vs. Temperature**

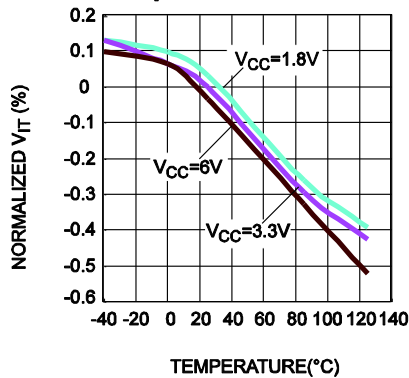

**$V_{HYS}$  vs. Temperature**

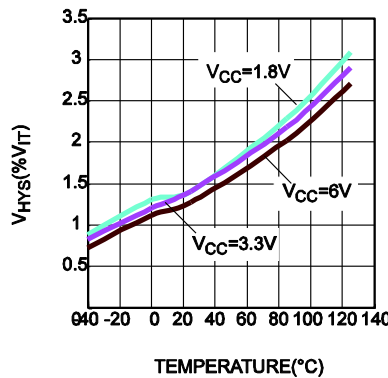

**$I_{RESET}$  vs. Low Level Reset Voltage**

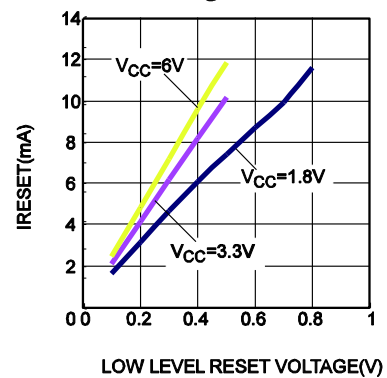

## FUNCTIONAL BLOCK DIAGRAM

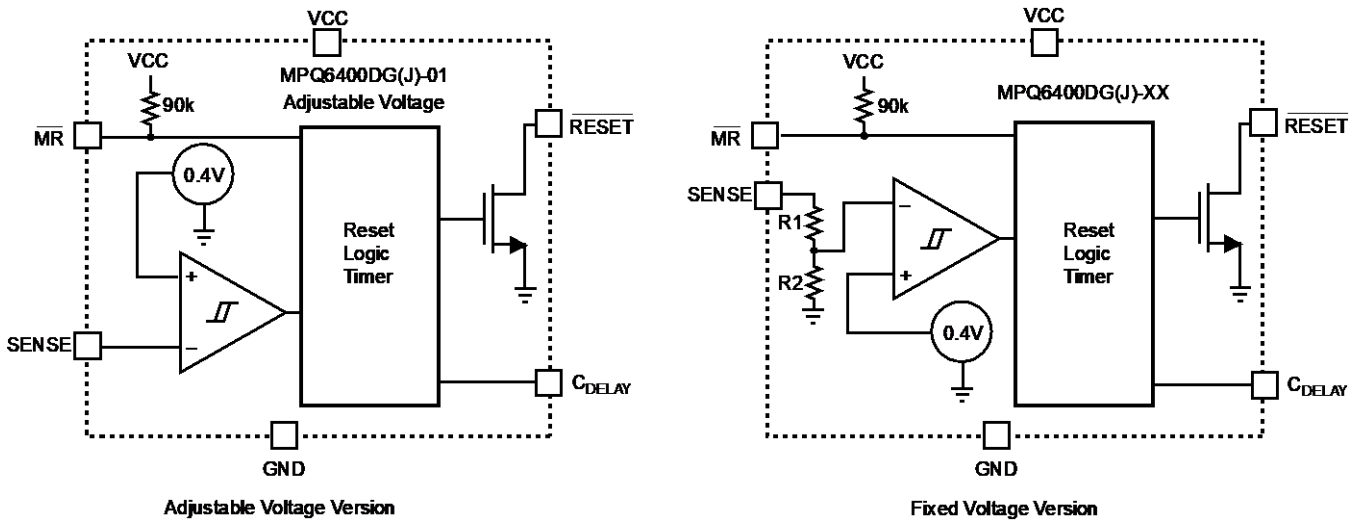

**Figure 1—Functional Block Diagram**

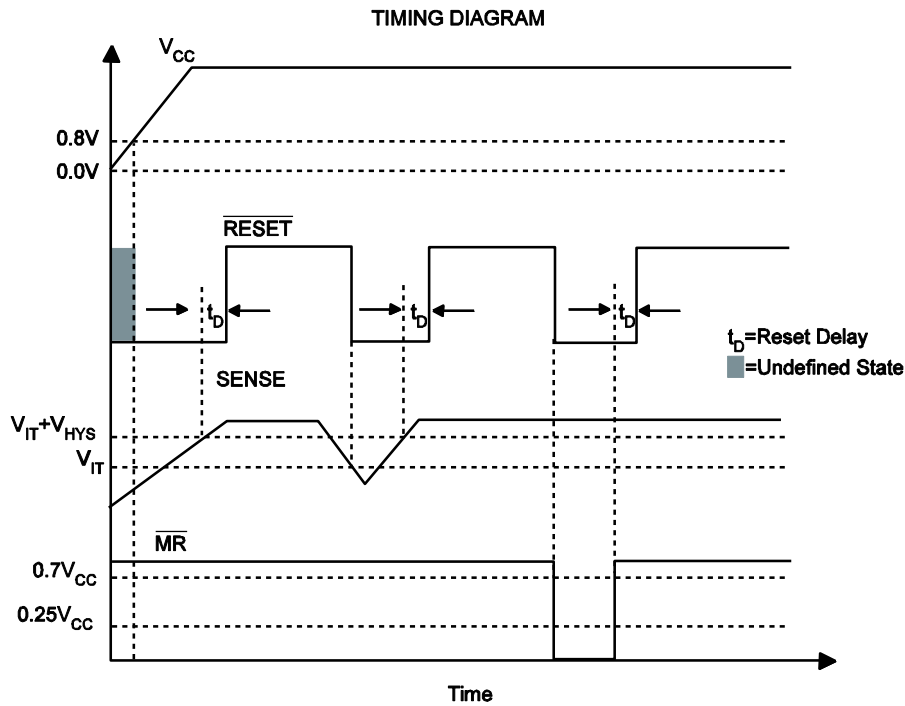

**Figure 2—MPQ6400 Timing Diagram**

**TRUTH TABLE**

MR	SENSE > V <sub>IT</sub>	RESET
L	0	L
L	1	L
H	0	L
H	1	H



## APPLICATION INFORMATION

### Reset Output Function

The MPQ6400  $\overline{\text{RESET}}$  output is typically connected to the  $\overline{\text{RESET}}$  input of a microprocessor, as shown in Figure 3. When  $\overline{\text{RESET}}$  is not asserted, a pull up resistor must be connected to hold this signal high. The voltage of reset signal is allowed to be higher than  $V_{CC}$  (up to 6V) through a resistor pulling up from supply line. If the voltage is below 0.8V,  $\overline{\text{RESET}}$  output is undefined. This condition can be ignored generally because that most microprocessors do not function at this state. When both SENSE and  $\overline{\text{MR}}$  are higher than their threshold voltage,  $\overline{\text{RESET}}$  output holds logic high. Once either of the two drops below their threshold,  $\overline{\text{RESET}}$  will be asserted.

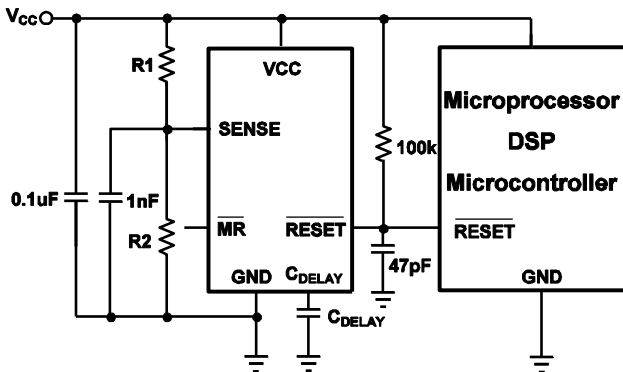

**Figure 3—Typical Application of MPQ6400 with Microprocessor**

From the point that  $\overline{\text{MR}}$  is again logic high and SENSE is above  $V_{IT} + V_{HYS}$  (the threshold hysteresis),  $\overline{\text{RESET}}$  will be driven to a logic high after a reset delay time. The reset delay time is programmable by  $C_{DELAY}$  pin. Due to the finite impedance of  $\overline{\text{RESET}}$  pin, the pull up resistor should be bigger than 10k $\Omega$ .

### Monitor a Voltage

The SENSE input pin is connected to the monitored system voltage directly or through a resistor network (on MPQ6400DG-01). When the voltage on the pin is below  $V_{IT}$ ,  $\overline{\text{RESET}}$  is asserted. A threshold hysteresis will prevent the chip from responding perturbation on SENSE pin. A 1nF to 10nF bypass capacitor should be put on this pin to increase its immunity to noise. A typical application of the MPQ6400DG-01 is shown in Figure 4. Two external resistors form a voltage

divider from monitored voltage to GND. Its tap connects to the SENSE pin. The circuit can be used to monitor any voltage higher than 0.4V.

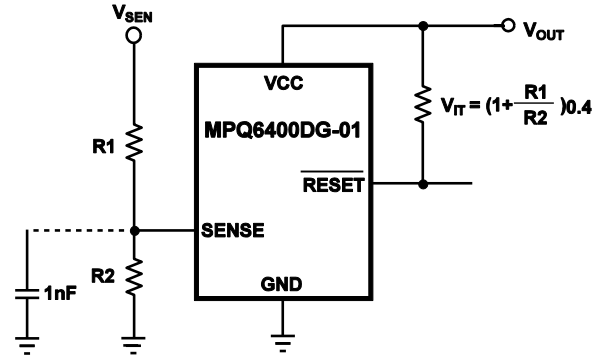

**Figure 4—MPQ6400DG-01 Monitoring a User-Defined Voltage**

### Monitor Multiple System Voltages

The manual reset ( $\overline{\text{MR}}$ ) can introduce another logic signal to control the  $\overline{\text{RESET}}$ . When  $\overline{\text{MR}}$  is a logic low ( $0.25V_{CC}$ ),  $\overline{\text{RESET}}$  will be asserted. After both SENSE and  $\overline{\text{MR}}$  are above their thresholds,  $\overline{\text{RESET}}$  will be driven to a logic high after a reset delay time. The  $\overline{\text{MR}}$  is internally connected to  $V_{CC}$  through a 90k $\Omega$  resistor so this pin can float. See how multiple system voltages are monitored by  $\overline{\text{MR}}$  in Figure 5. If the signal on  $\overline{\text{MR}}$  isn't up to  $V_{CC}$ , there will be an additional current through internal 90k $\Omega$  pull up resistor. A logic-level FET can be used to minimize the leakage, as shown in Figure 6.

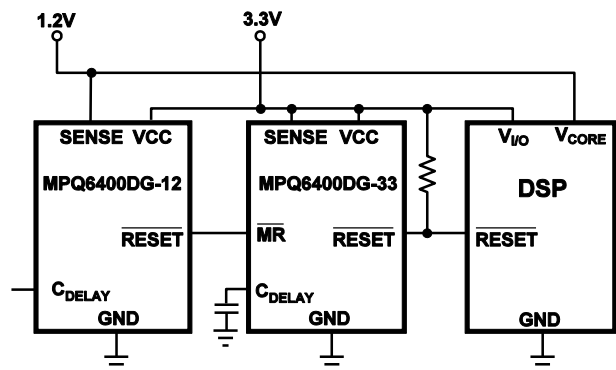

**Figure 5—MPQ6400 Family Monitoring Multiple System Voltages**

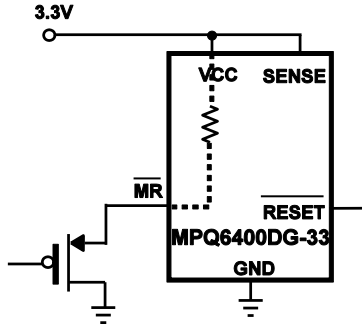

**Figure 6—Minimizing I<sub>CC</sub> When  $\overline{MR}$  Signal isn't over V<sub>CC</sub> by External MOSFET**

**Programmable Reset Delay Time**

The reset delay time can be programmed by C<sub>DELAY</sub> configure. When C<sub>DELAY</sub> is connected to VCC through a resistor between 50kΩ and 200kΩ, the delay time is 380ms. When C<sub>DELAY</sub> floated, the delay time is 24ms. In addition, a capacitor connected C<sub>DELAY</sub> to GND could be used to get the user's programmable delay time from 2.1ms to 10s. The three configures can be found in Figure 7(a)(b)(c).

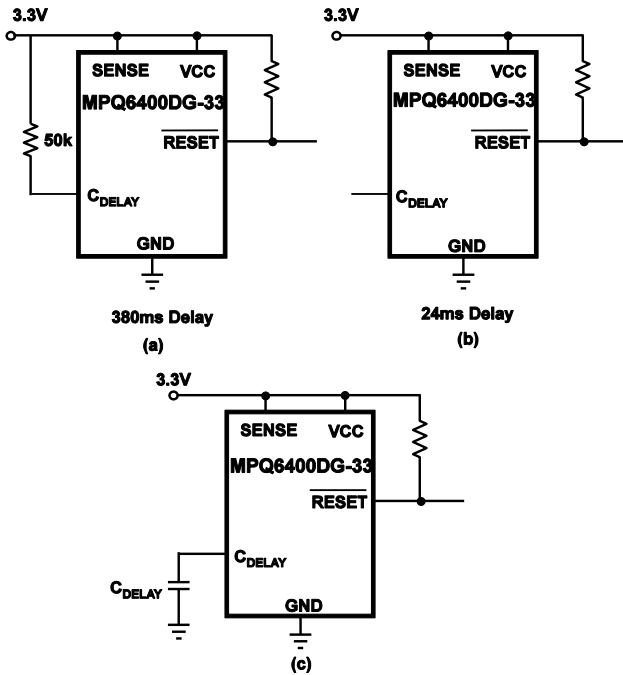

**Figure 7—Programmable Configurations to the Reset Delay Time**

The external capacitor C<sub>DELAY</sub> must be larger than 150pF. For a given delay time, the capacitor value can be calculated using the following equation:

$$C_{DELAY}(\text{nF}) = [t_D(\text{s}) - 4.99 \times 10^{-4}(\text{s})] \times 107$$

The reset delay time is determined by the charge time of external capacitor. While SENSE is above V<sub>IT</sub> and  $\overline{MR}$  is a logic high, the internal 140nA current source is enabled and starts to charge the capacitor to set the delay time. When the capacitor voltage rises to 1.13V, the  $\overline{RESET}$  is de-asserted. The capacitor will be discharged when the  $\overline{RESET}$  is again asserted. Stray capacitance may cause errors of the delay time. A ceramic capacitor with low leakage is strongly recommended.

**SENSE Voltage Transients Immunity**

The MPQ6400 can be immune to SENSE pin short negative transient. The maximum immune duration is 17us while overdrive is 5%. A shorter negative transient can not assert the  $\overline{RESET}$  output. The effective duration is relative to the threshold overdrive, as shown in Figure 8.

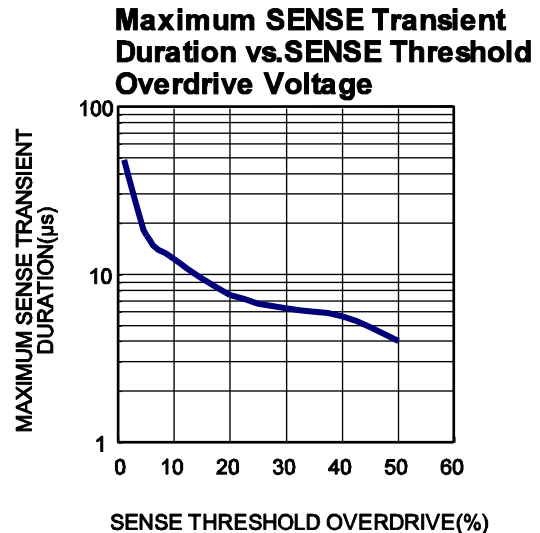

**Figure 8—Maximum Transient Duration vs. Sense Threshold Overdrive Voltage**

**PACKAGE INFORMATION**

**QFN-6 (2mmx2mm)**

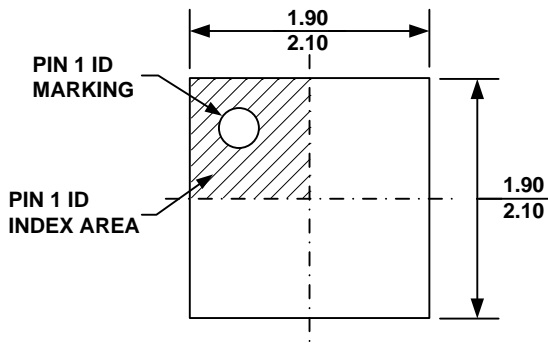

**TOP VIEW**

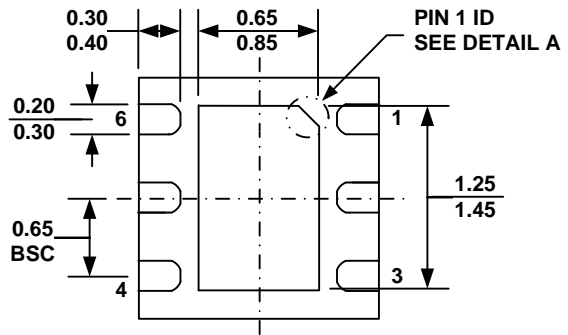

**BOTTOM VIEW**

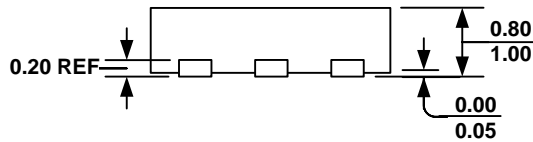

**SIDE VIEW**

**PIN 1 ID OPTION A**  
0.30x45° TYP.

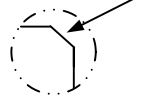

**PIN 1 ID OPTION B**  
R0.20 TYP.

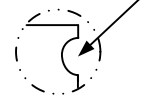

**DETAIL A**

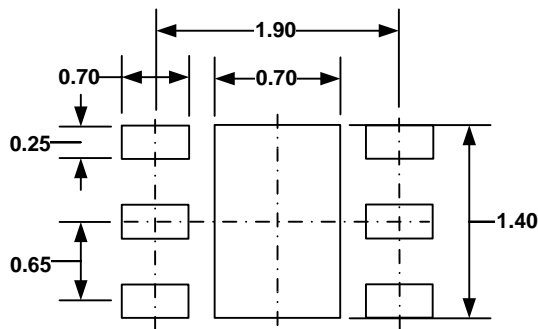

**RECOMMENDED LAND PATTERN**

**NOTE:**

- 1) ALL DIMENSIONS ARE IN MILLIMETERS.
- 2) EXPOSED PADDLE SIZE DOES NOT INCLUDE MOLD FLASH.
- 3) LEAD COPLANARITY SHALL BE 0.10 MILLIMETER MAX.
- 4) JEDEC REFERENCE IS MO-229, VARIATION VCCC.
- 5) DRAWING IS NOT TO SCALE.

**PACKAGE INFORMATION (continued)**

**TSOT23-6**

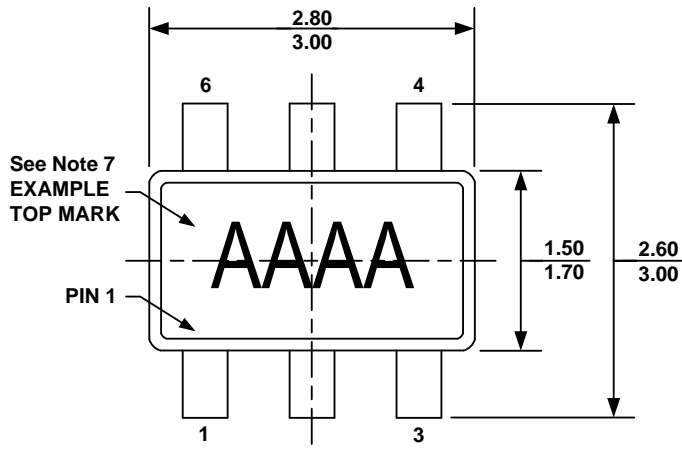

**TOP VIEW**

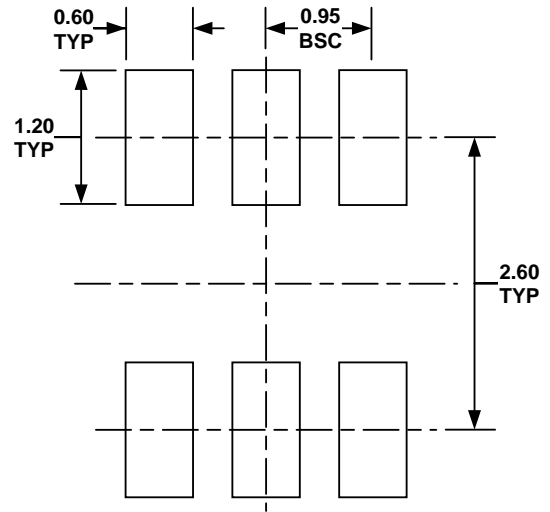

**RECOMMENDED LAND PATTERN**

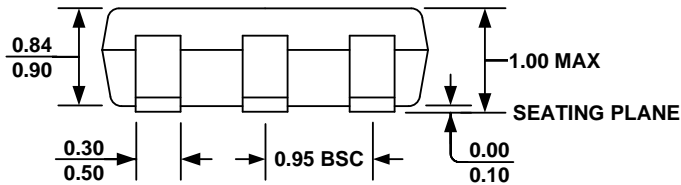

**FRONT VIEW**

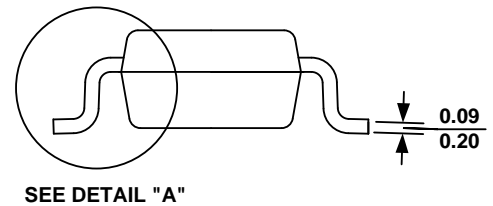

**SEE DETAIL "A"**

**SIDE VIEW**

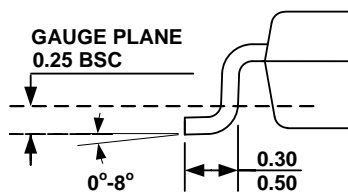

**DETAIL "A"**

**NOTE:**

- 1) ALL DIMENSIONS ARE IN MILLIMETERS.
- 2) PACKAGE LENGTH DOES NOT INCLUDE MOLD FLASH, PROTRUSION OR GATE BURR.
- 3) PACKAGE WIDTH DOES NOT INCLUDE INTERLEAD FLASH OR PROTRUSION.
- 4) LEAD COPLANARITY (BOTTOM OF LEADS AFTER FORMING) SHALL BE 0.10 MILLIMETERS MAX.
- 5) DRAWING CONFORMS TO JEDEC MO-193, VARIATION AB.
- 6) DRAWING IS NOT TO SCALE.
- 7) PIN 1 IS LOWER LEFT PIN WHEN READING TOP MARK FROM LEFT TO RIGHT, (SEE EXAMPLE TOP MARK)

**CARRIER INFORMATION**

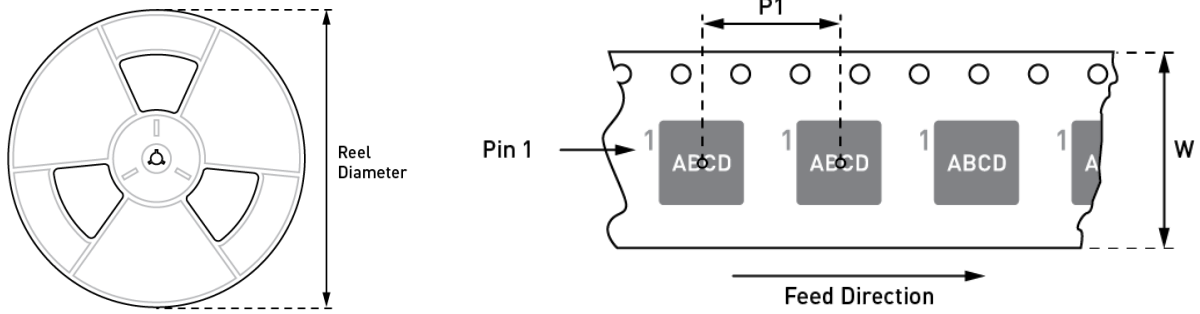

Part Number	Package Description	Quantity /Reel	Reel Diameter	Carrier Tape Width	Carrier Tape Pitch
MPQ6400DG-33-Z	QFN-6 (2mmx2mm)	5000	13in	12mm	8mm
MPQ6400DG-33-AEC1-Z					
MPQ6400DG-01-Z					
MPQ6400DG-01-AEC1-Z					
MPQ6400DJ-33-AEC1-Z	TSOT23-6	3000	7in	8mm	4mm
MPQ6400DJ-01-AEC1-Z					

## REVERISON HISTORY

Revision #	Revision Date	Description	Pages Updated
1.0	12/5/2011	Initial	-
1.11	5/8/2018	Add MPQ6400-01 ordering information with under qualification note and top marking information	2
1.12	11/4/2019	Add MSL information	2
		Add ESD information	3
		Updated EC according to ATE result a) Negative-going input threshold accuracy b) Input current at SENSE pin c) RESET leakage current	5
		Added Carrier information	11
1.2	10/23/2023	<ul style="list-style-type: none"> <li>Updated the Description section                             <ul style="list-style-type: none"> <li>Grammar and formatting updates</li> <li>Added the TSOT23-6 package</li> </ul> </li> <li>Updated the Features section:                             <ul style="list-style-type: none"> <li>Deleted “Guaranteed Industrial/Automotive Temp Range Limits”</li> <li>Updated “Power-On Reset Generator with Adjustable Delay Time” to “Adjustable Reset Delay Time”</li> <li>Updated the Fixed Voltage Threshold and Adjustable Voltage Threshold bullet points</li> <li>Added package information</li> </ul> </li> <li>Grammar and formatting updates</li> <li>Deleted “(ADAS)”</li> <li>Updated the Applications section</li> </ul>	1
		Updated “MPQ6400DG-01” to “MPQ6400DG(J)-01”	1, 6
		Updated “-Z” to “-Z”, “-LF” to “-LF”, and “-XX” to “-XX”	2
		Added the MPQ6400DJ ordering information, top marking, and package reference	2, 3
		Added the TSOT23-6 line in the Absolute Maximum Ratings section; added the ESD Ratings section; added the TSOT23-6 line in the Thermal Resistance section; added note 3 and note 4	4
		Updated note numbers	5
		Added the MPQ6400DJ ordering information and pin function information	6
		Updated “MPQ6400DG-01” to “MPQ6400DG(J)-01” and “MPQ6400DG-XX” to “MPQ6400DG(J)-XX” in Figure 1	8
		Added the MPQ6400DJ package information	12
		Add the MPQ6400DJ carrier information	13
		Updated “Supervisory Circuit” to “Voltage Supervisor” in headers	All

**NOTICE:** The information in this document is subject to change without notice. Users should warrant and guarantee that third party Intellectual Property rights are not infringed upon when integrating MPS products into any application. MPS will not assume any legal responsibility for any said applications.