

TSSF212 SERIES

1/2" NPT EXTERNAL MOUNT WITH TEMPERATURE SENSING



The TSSF212 series is a compact external fitting device, via 1/2" NPT thread, with a high specification thermistor so capable of sensing both liquid level and temperature.

The device does not require access to the inside of the tank.

Application of the product is typically used in the pharmaceutical industry, food and beverage and dairies industry, as well as biofuel industry.

They are manufactured in stainless steel, to suit most commonly used liquids.

The switch action may be reversed by rotating the device through 180°.

Features

- Compact design with temperature sensing
- 1/2" NPT thread for external mount
- 25VA & 100VA versions
- Float material SS 316, stem material SS 304
- N/O or N/C switching action
- Temperature measurement from -20°C to +120°C

SPECIFICATIONS

Technical

Mounting Style	External
Mounting Thread	1/2" NPT
Float & Stem Material	SS 316 & SS 304
Maximum Temperature	-20°C to +120°C
Maximum Pressure	10 bar
Float SG	0.7
Minimum Fluid SG	0.8

Electrical

		25W (Y Code)	100W (H Code)
Contact Form		N/O (N/C)	N/O (N/C)
Switching Power Max	VA	25	100
Switching Voltage AC Max	V	240	300
Switching Voltage DC Max	V	120	300
Switching Current Max	A	0.6	1

Thermistor

Nominal Temperature Resistance	10k Ohm at 25°C
Resistance Tolerance	+/- 1% (25°C) to +/- 4.3% (120°C)
Operating Temperature Range	-20°C to +120°C
Temperature Sensing Accuracy	+/-0.2°C (0°C to +70°C)
Beta Value	3892K (0/50°C)
Response Time	<1 sec

STANDARD PARTS

	Temperature	Max Power	Leadouts	Output
TSSF212H100	-20°C to +120°C	100VA	100cm XLPE AWG 22	SPNO + Temp
TSSF212Y100	-20°C to +120°C	25VA	100cm XLPE AWG 22	SPNO + Temp

Custom versions can be made for particular applications. Please contact Sensata with your requirements.

DIMENSIONS

All dimensions are in millimeters.

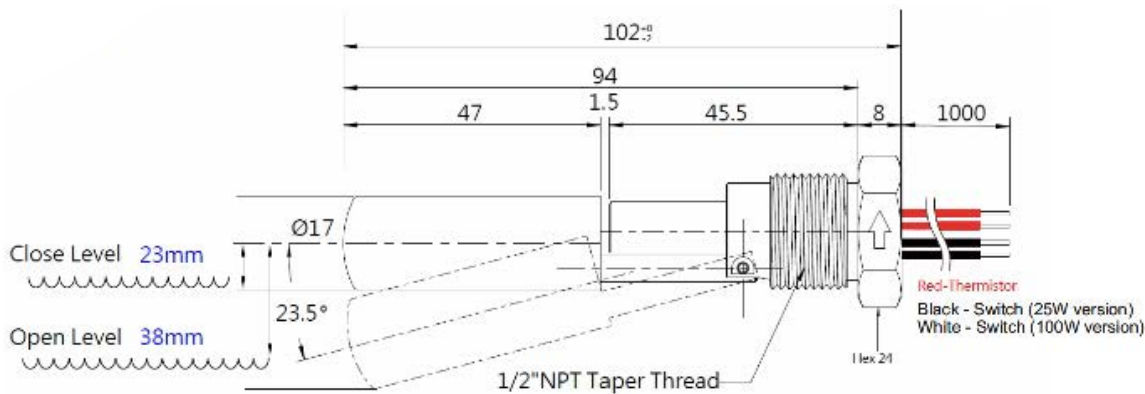

Made in the UK

Page 2

Datasheets provided by Sensata Technologies, Inc., its subsidiaries and/or affiliates ("Sensata") are solely intended to assist third parties ("Buyers") who are developing systems that incorporate Sensata products (also referred to herein as "components"). Buyer understands and agrees that Buyer remains responsible for using its independent analysis, valuation, and judgment in designing Buyer's systems and products. Sensata datasheets have been created using standard laboratory conditions and engineering practices. Sensata has not conducted any testing other than that specifically described in the published documentation for a particular datasheet. Sensata may make corrections, enhancements, improvements, and other changes to its datasheets or components without notice. Buyers are authorized to use Sensata datasheets with the Sensata component(s) identified in each particular datasheet. HOWEVER, NO OTHER LICENSE, EXPRESS OR IMPLIED, BY ESTOPPEL OR OTHERWISE TO ANY OTHER SENSATA INTELLECTUAL PROPERTY RIGHT, AND NO LICENSE TO ANY THIRD PARTY TECHNOLOGY OR INTELLECTUAL PROPERTY RIGHT, IS GRANTED HEREIN. SENSATA DATASHEETS ARE PROVIDED "AS IS". SENSATA MAKES NO WARRANTIES OR REPRESENTATIONS WITH REGARD TO THE DATASHEETS OR USE OF THE DATASHEETS, EXPRESS, IMPLIED, OR STATUTORY, INCLUDING ACCURACY OR COMPLETENESS. SENSATA DISCLAIMS ANY WARRANTY OF TITLE AND ANY IMPLIED WARRANTIES OF MERCHANTABILITY, FITNESS FOR A PARTICULAR PURPOSE, QUIET ENJOYMENT, QUIET POSSESSION, AND NON-INFRINGEMENT OF ANY THIRD PARTY INTELLECTUAL PROPERTY RIGHTS WITH REGARD TO SENSATA DATASHEETS OR USE THEREOF.

All products are sold subject to Sensata's terms and conditions of sale supplied at www.sensata.com. SENSATA ASSUMES NO LIABILITY FOR APPLICATIONS ASSISTANCE OR THE DESIGN OF BUYERS' PRODUCTS. BUYER ACKNOWLEDGES AND AGREES THAT IT IS SOLELY RESPONSIBLE FOR COMPLIANCE WITH ALL LEGAL, REGULATORY, AND SAFETY-RELATED REQUIREMENTS CONCERNING ITS PRODUCTS, AND ANY USE OF SENSATA COMPONENTS IN ITS APPLICATIONS, NOTWITHSTANDING ANY APPLICATIONS-RELATED INFORMATION OR SUPPORT THAT MAY BE PROVIDED BY SENSATA.

Mailing Address: Sensata Technologies, Inc., 529 Pleasant Street, Attleboro, MA 02703, USA

CONTACT US

+44 (0)1202 897969
support@sensata.com
 Cynergy3 Components Ltd.
 7 Cobham Road,
 Ferndown Industrial Estate,
 Wimborne, Dorset,
 BH21 7PE, United Kingdom