

## LLF40 SERIES

### COMPACT INTERNAL FITTING, LOW LEVEL, LOW S.G. FLOAT SWITCH



The LLF40 series is designed as a compact internal fitting device, with a wide range of options, making this ideal for size sensitive applications. Mounting of this series requires access to the inside of the tank.

These devices are particularly suitable for detecting low levels of liquids in the bottom of tanks and containers, and for lower SG liquids. Typical applications include vending machines, commercial washing machines and evaporator units.

They are manufactured in a variety of materials with a choice of gasket materials, to suit most commonly used liquids.

The switch action may be reversed by rotating the device through 180°.

Available with flying leads or M12 socket for electrical connection. Cable sets with M12 plugs are also available.

Custom versions can be made for particular applications.

#### Features

- Suitable for low specific gravity liquids (0.7 S.G.)
- Very low level sensing
- Class leading compact design
- Flying Lead or M12 plug connection
- Available in Nylon, Polypropylene, PPS or PVDF
- 25VA & 100VA versions
- Many variants are UL recognised components File No. E171218
- Many variants have WRAS and/or UL approval

## SPECIFICATIONS

### Technical

	LLF43	LLF44	LLF48	LLF46	LLF47
<b>Material</b>	Nylon	Polypropylene WRAS approved	Polypropylene UL approved	Polyphenylene Sulphide (PPS)	Polyvinylidene Fluoride (PVDF)
<b>Colour</b>	Black	Opaque	White	Grey	Green
<b>Temp. Range</b>	°C °F	-20/+75	-20/+100	-10/+120*	-10/+105
		-4/+167	-4/+212	-4/+212	+14/+248*
<b>Min. Fluid SG</b>	0.7	0.7	0.7	0.7	0.7
<b>Must Close Level (SG=1)</b>	1mm	1mm	1mm	1mm	1mm
<b>Must Open Level (SG=1)</b>	10mm	10mm	10mm	10mm	10mm

\* ETFE cable needs to be selected in order to achieve the maximum temperature rating

## Electrical

		<b>25W (Y code)</b>	<b>100W (H code)</b>
<b>Contact Form</b>		N/O (N/C)	N/O (N/C)
<b>Switching Power Max</b>	VA	25	100
<b>Switching Voltage AC Max</b>	V	240	300
<b>Switching Voltage DC Max</b>	V	120	300
<b>Switching Current Max</b>	A	0.6	1

All ratings are for resistive load only.

## STANDARD PARTS

	<b>Material</b>	<b>Max Power</b>	<b>Leadouts</b>	<b>Gasket</b>	<b>Approvals</b>
<b>LLF43H100RF</b>	Nylon	100VA	100cm PVC 16/0.2	Nitrile	WRAS
<b>LLF43Y100RF</b>	Nylon	25VA	100cm PVC 16/0.2	Nitrile	WRAS
<b>LLF44H100RF</b>	PP	100VA	100cm PVC 16/0.2	Nitrile	WRAS
<b>LLF44Y100RF</b>	PP	25VA	100cm PVC 16/0.2	Nitrile	WRAS
<b>LLF46H100RF</b>	PPS	100VA	100cm PVC 16/0.2	Nitrile	WRAS & UL
<b>LLF46Y100RF</b>	PPS	25VA	100cm PVC 16/0.2	Nitrile	WRAS & UL
<b>LLF47Y100GF</b>	PVDF	25VA	100cm PTFE 7/0.2	Nitrile	UL
<b>LLF47H100GF</b>	PVDF	100VA	100cm PTFE 7/0.2	Nitrile	UL
<b>LLF47Y100GG</b>	PVDF	25VA	100cm PTFE 7/0.2	Viton	UL
<b>LLF47H100GG</b>	PVDF	100VA	100cm PTFE 7/0.2	Viton	UL
<b>LLF48H100RF</b>	PP (UL)	100VA	100cm PVC 16/0.2	Nitrile	UL
<b>LLF48Y100RF</b>	PP (UL)	25VA	100cm PVC 16/0.2	Nitrile	UL
<b>LLF43HFP</b>	Nylon	100VA	M12 connector	Nitrile	WRAS
<b>LLF43YFP</b>	Nylon	25VA	M12 connector	Nitrile	WRAS
<b>LLF44HFP</b>	PP	100VA	M12 connector	Nitrile	WRAS
<b>LLF44YFP</b>	PP	25VA	M12 connector	Nitrile	WRAS
<b>LLF46HFP</b>	PPS	100VA	M12 connector	Nitrile	WRAS & UL
<b>LLF46YFP</b>	PPS	25VA	M12 connector	Nitrile	WRAS & UL
<b>LLF47YFP</b>	PVDF	25VA	M12 connector	Nitrile	UL
<b>LLF47HFP</b>	PVDF	100VA	M12 connector	Nitrile	UL
<b>LLF47YGP</b>	PVDF	25VA	M12 connector	Viton	UL
<b>LLF47HGP</b>	PVDF	100VA	M12 connector	Viton	UL
<b>LLF48HFP</b>	PP (UL)	100VA	M12 connector	Nitrile	UL
<b>LLF48YFP</b>	PP (UL)	25VA	M12 connector	Nitrile	UL



## DIMENSIONS

All dimensions are in millimeters.

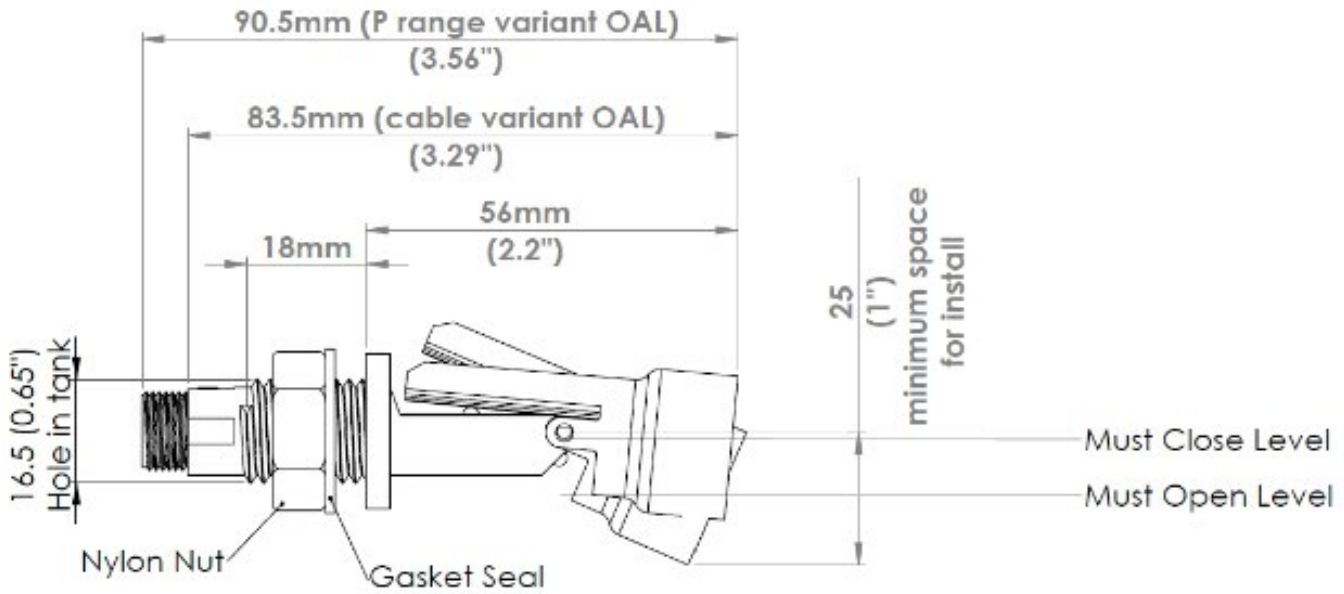

### Electrical Connections

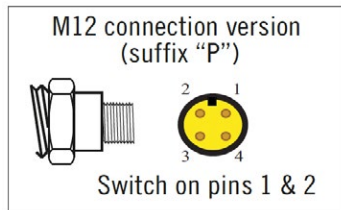

Made in the UK

Page 3

Datasheets provided by Sensata Technologies, Inc., its subsidiaries and/or affiliates ("Sensata") are solely intended to assist third parties ("Buyers") who are developing systems that incorporate Sensata products (also referred to herein as "components"). Buyer understands and agrees that Buyer remains responsible for using its independent analysis, valuation, and judgment in designing Buyer's systems and products. Sensata datasheets have been created using standard laboratory conditions and engineering practices. Sensata has not conducted any testing other than that specifically described in the published documentation for a particular datasheet. Sensata may make corrections, enhancements, improvements, and other changes to its datasheets or components without notice.

Buyers are authorized to use Sensata datasheets with the Sensata component(s) identified in each particular datasheet. HOWEVER, NO OTHER LICENSE, EXPRESS OR IMPLIED, BY ESTOPPEL OR OTHERWISE TO ANY OTHER SENSATA INTELLECTUAL PROPERTY RIGHT, AND NO LICENSE TO ANY THIRD PARTY TECHNOLOGY OR INTELLECTUAL PROPERTY RIGHT, IS GRANTED HEREIN. SENSATA DATASHEETS ARE PROVIDED "AS IS". SENSATA MAKES NO WARRANTIES OR REPRESENTATIONS WITH REGARD TO THE DATASHEETS OR USE OF THE DATASHEETS, EXPRESS, IMPLIED, OR STATUTORY, INCLUDING ACCURACY OR COMPLETENESS. SENSATA DISCLAIMS ANY WARRANTY OF TITLE AND ANY IMPLIED WARRANTIES OF MERCHANTABILITY, FITNESS FOR A PARTICULAR PURPOSE, QUIET ENJOYMENT, QUIET POSSESSION, AND NON-INFRINGEMENT OF ANY THIRD PARTY INTELLECTUAL PROPERTY RIGHTS WITH REGARD TO SENSATA DATASHEETS OR USE THEREOF.

All products are sold subject to Sensata's terms and conditions of sale supplied at [www.sensata.com](http://www.sensata.com). SENSATA ASSUMES NO LIABILITY FOR APPLICATIONS ASSISTANCE OR THE DESIGN OF BUYERS' PRODUCTS. BUYER ACKNOWLEDGES AND AGREES THAT IT IS SOLELY RESPONSIBLE FOR COMPLIANCE WITH ALL LEGAL, REGULATORY, AND SAFETY-RELATED REQUIREMENTS CONCERNING ITS PRODUCTS, AND ANY USE OF SENSATA COMPONENTS IN ITS APPLICATIONS, NOTWITHSTANDING ANY APPLICATIONS-RELATED INFORMATION OR SUPPORT THAT MAY BE PROVIDED BY SENSATA.

Mailing Address: Sensata Technologies, Inc., 529 Pleasant Street, Attleboro, MA 02703, USA

### CONTACT US

+44 (0)1202 897969  
 support@sensata.com  
 Cynergy3 Components Ltd.  
 7 Cobham Road,  
 Ferndown Industrial Estate,  
 Wimborne, Dorset,  
 BH21 7PE, United Kingdom