

QT-Brightek Chip LED Series

SMD 1204 Side View (Right Angle) LED

Part No.: QBLP613_Series

Table of Contents:

Introduction	3
Electrical / Optical Characteristic (Ta=25 °C)	4
Absolute Maximum Rating	4
Characteristic Curves.....	7
Solder Profile & Footprint.....	9
Packing	10
Labeling	11
Ordering Information	11
Revision History	12
Disclaimer	12

Introduction

Feature:

- Water clear lens
- Package in tape and reel
- Side View (right angle) 1204 LED package
- AllnGaP technology for R/O/AG/Y
- InGaN technology for IB/IG
- Viewing Angle = 150 deg typ.

Description:

These bright side view 1204 LEDs have a height profile of 1.0mm. With higher packing density and smaller footprint, these LEDs are ideal for smaller equipment and miniature application.

Application:

- Status indication
- Back lighting application
- General Use

Certification & Compliance:

- ISO9001
- RoHS Compliant

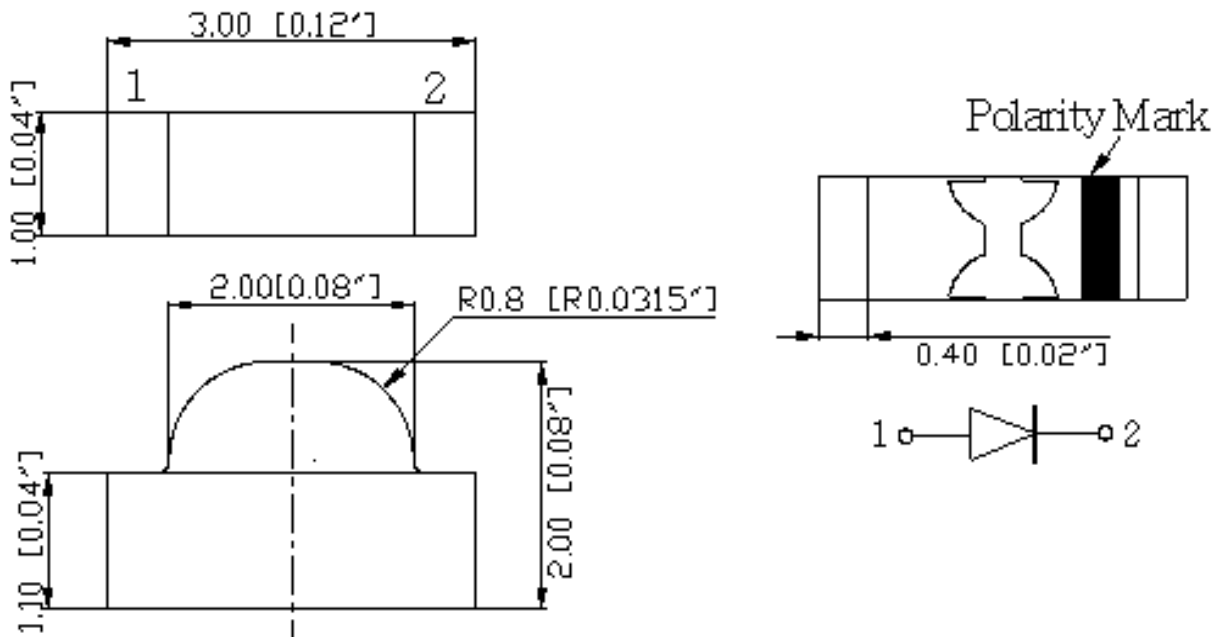
**Dimension:**

Units: mm / tolerance = +/-0.1mm

Electrical / Optical Characteristic (Ta=25 °C)

Product	Color	I _F (mA)	V _F (V)		λ _D (nm)			I _V (mcd)	
			Typ.	Max.	Min.	Typ.	Max.	Min.	Typ.
QBLP613-R	Red	20	2.0	2.5	625	630	635	50	85
QBLP613-O	Orange	20	2.0	2.5	600	605	610	80	180
QBLP613-Y	Yellow	20	2.0	2.5	585	590	595	80	170
QBLP613-AG	Yellow Green	20	2.0	2.5	565	570	576	25	40
QBLP613-IB	Blue	20	3.1	3.7	465	470	475	80	100
QBLP613-IG	True Green	20	3.1	3.7	520	525	530	200	370

Absolute Maximum Rating

Material	P _d (mW)	I _F (mA)	I _{FP} (mA)*	V _R (V)	T _{OP} (°C)	T _{ST} (°C)	T _{SO L} (°C)**
AllnGaP (R/AG/Y)	75	30	125	5	-40 ~ +80	-40 ~ +85	260
InGaN (IB/IG)	111	30	125	5	-40 ~ +80	-40 ~ +85	260

**Duty 1/8 @ 1KHz

**IR Reflow for no more than 10 sec @ 260 °C

Forward Voltage V_F @ I_F=20mA for AllnGaP

Bin	Min.	Max.	Unit
□	1.7	2.5	V

Forward Voltage V_F @ I_F=20mA for InGaN

Bin	Min.	Max.	Unit
f	2.8	3.1	V
g	3.1	3.4	
h	3.4	3.7	

Luminous Intensity I_V @ $I_F=20mA$

Bin	Min.	Max.	Unit
D	25	32	mcd
E	32	40	
F	40	50	
G	50	63	
H	63	80	
I	80	100	
J	100	125	
K	125	160	
L	160	200	
M	200	250	
N	250	320	
O	320	400	
P	400	500	
Q	500	630	

Dominant Wavelength λ_D for Blue @ $I_F=20mA$

Bin	Min.	Max.	Unit
G	465	467.5	nm
H	467.5	470	
I	470	470.5	
J	472.5	475	

Dominant Wavelength λ_D for True Green @ $I_F=20mA$

Bin	Min.	Max.	Unit
U	520	522.5	nm
V	522.5	525	
W	525	527.5	
X	527.5	530	

Dominant Wavelength λ_D for Red @ $I_F=20mA$

Bin	Min.	Max.	Unit
u	625	630	nm
v	630	635	

Dominant Wavelength λ_D for Orange @ $I_F=20mA$

Bin	Min.	Max.	Unit
p	600	605	nm
q	605	610	

Dominant Wavelength λ_D for Yellow Green @ $I_F=20mA$

Bin	Min.	Max.	Unit
h	565	568	nm
i	568	572	
j	572	576	

Dominant Wavelength λ_D for Yellow @ $I_F=20mA$

Bin	Min.	Max.	Unit
m	585	590	nm
n	590	595	

Characteristic Curves

AllnGaP (R/O/AG/Y)

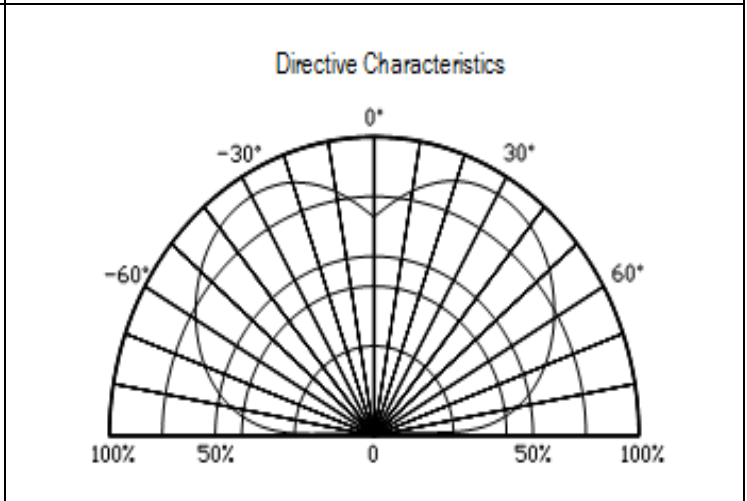
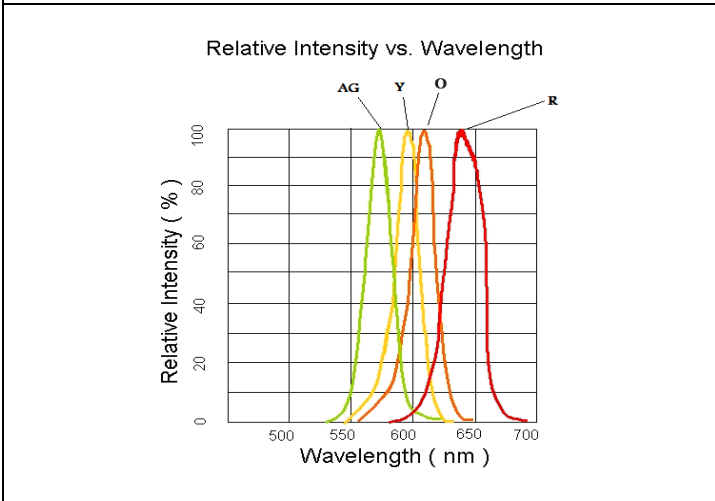
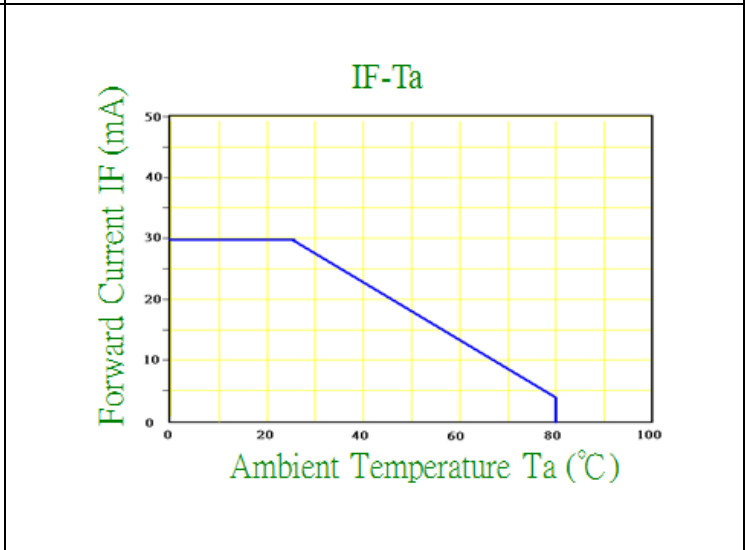
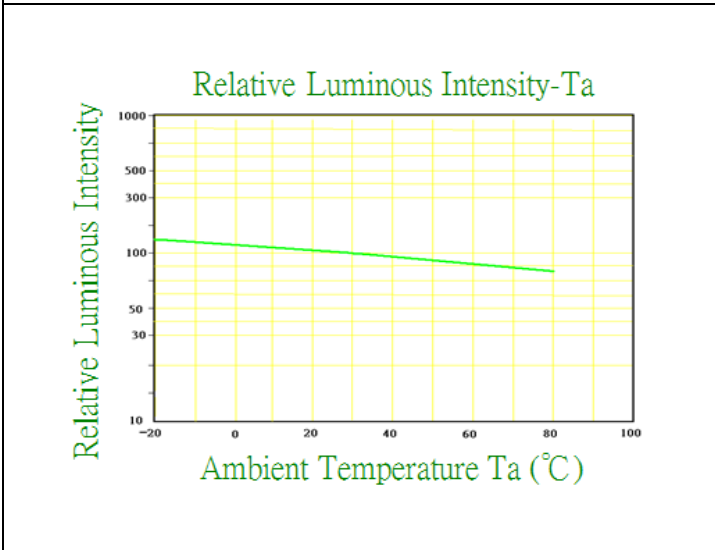
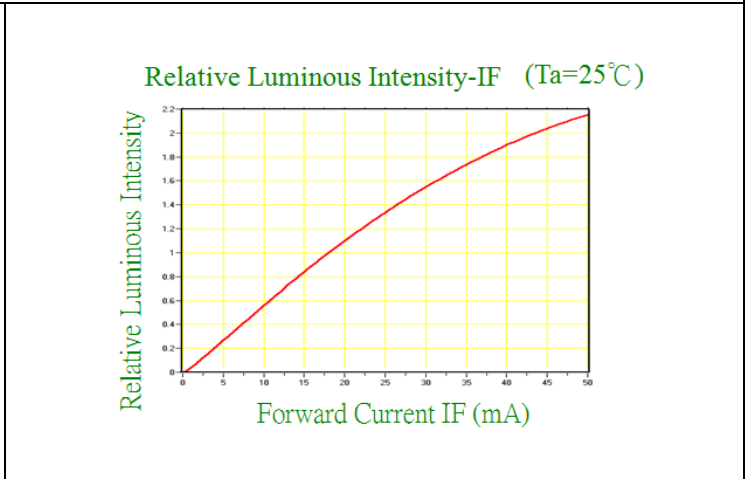
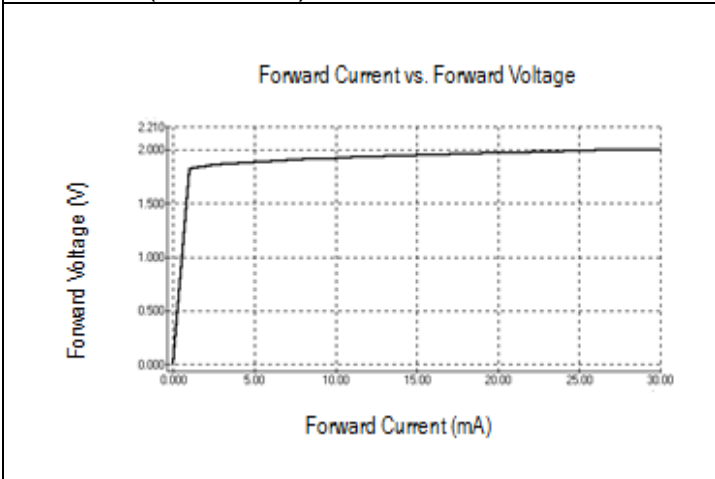

InGaN (IB/IG)

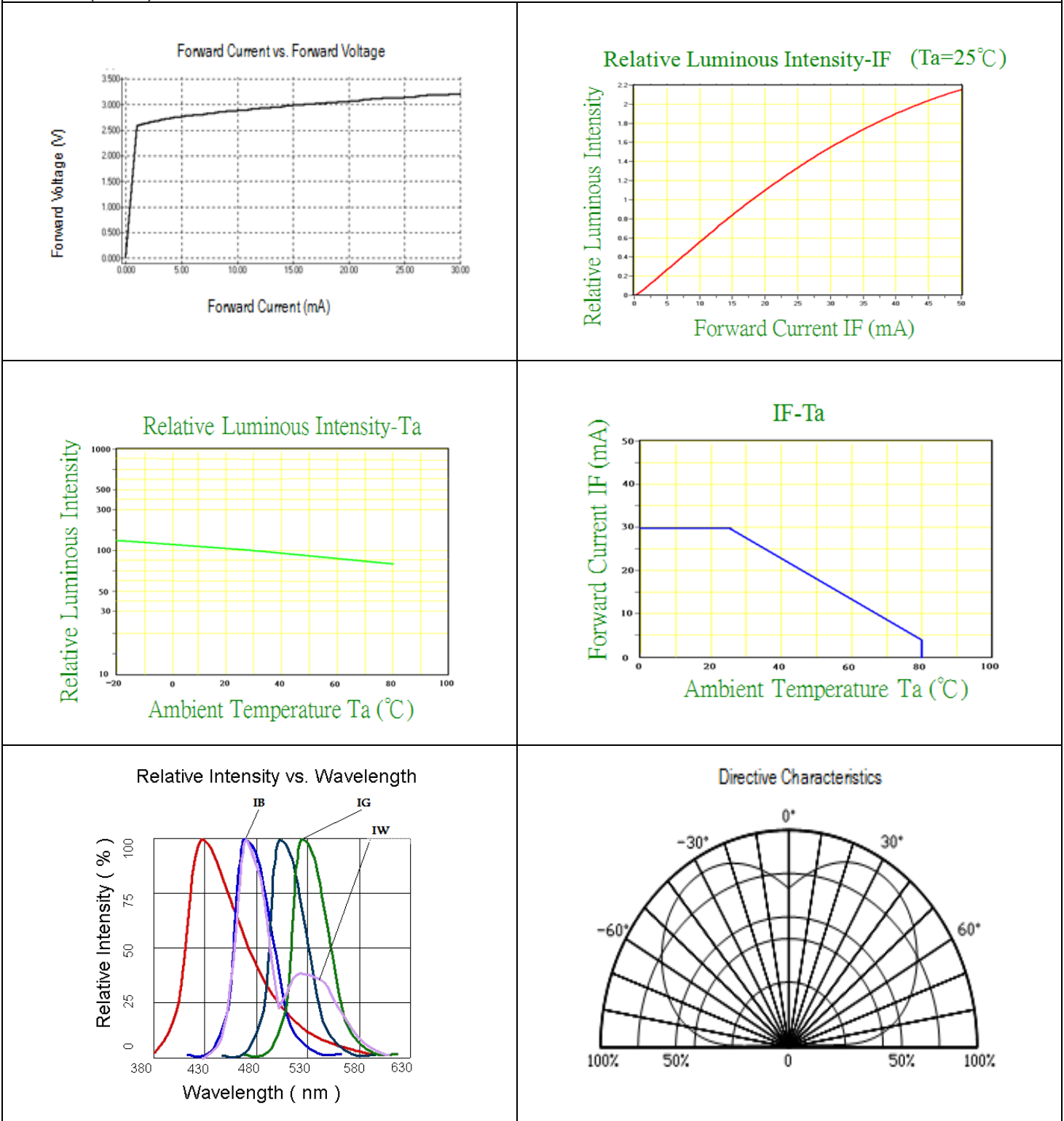

Solder Profile & Footprint

- Recommended tin solder specifications: melting temperature in the range of 178~192°C
- The recommended reflow soldering profile is as follows (temperatures indicated are as measured on the surface of the LED resin):

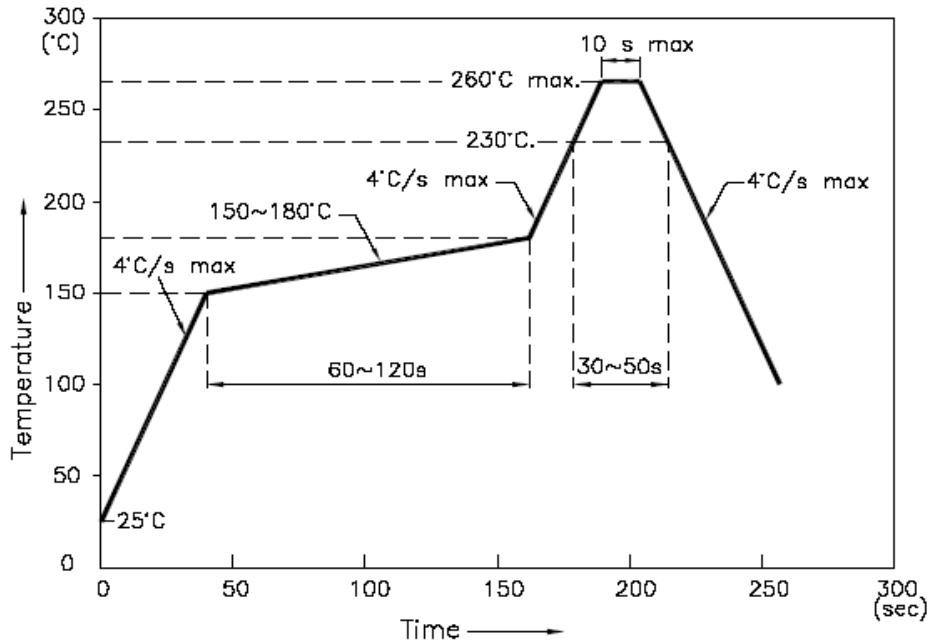

Recommended Pad Layout

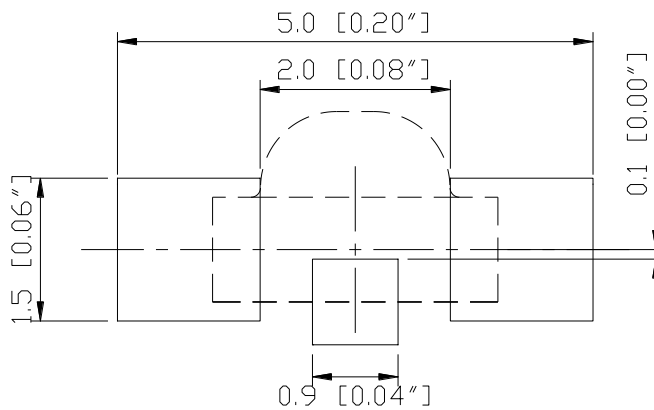

Units: mm

Packing

Reel Dimension:

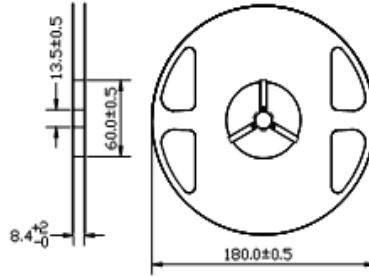

Unit: mm

Tape Dimension:

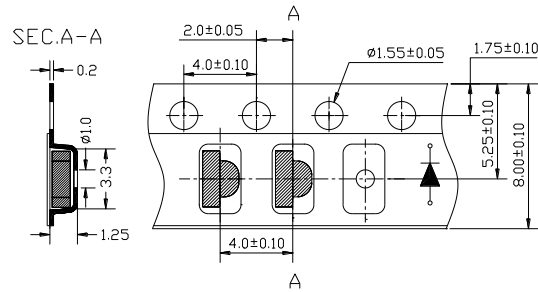

Unit: mm

Arrangement of Tape:

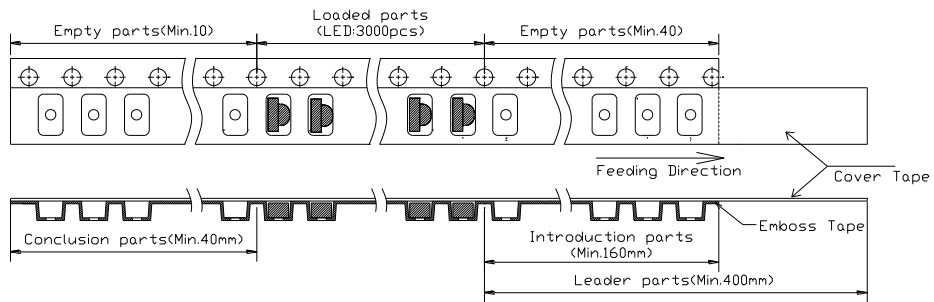

Packaging Specifications:

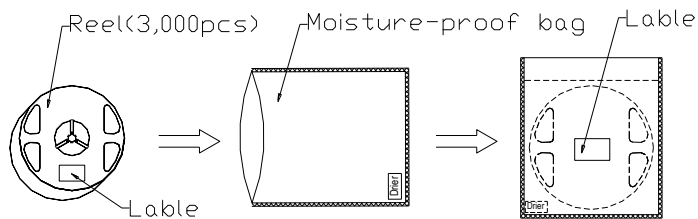

Labeling

Part No: _____

Customer P/N: _____

Item: _____

Q'ty: _____

Vf: _____

Iv: _____

WI: _____

Date: _____

Made in China**Ordering Information**

Orderable Part #	Spec Range	Quantity per reel
QBLP613-R	Iv=85mcd typ. @ 20mA / Color= 625nm to 635nm	3,000 units
QBLP613-O	Iv=180mcd typ. @ 20mA / Color= 600nm to 610nm	3,000 units
QBLP613-AG	Iv=40mcd typ. @ 20mA / Color= 565nm to 576nm	3,000 units
QBLP613-Y	Iv=170mcd typ. @ 20mA / Color = 585nm to 595nm	3,000 units
QBLP613-IB	Iv=100mcd typ. @ 20mA / Color= 465nm to 475nm	3,000 units
QBLP613-IG	Iv=370mcd typ. @ 20mA / Color= 520nm to 530nm	3,000 units

Revision History

Description:	Revision #	Revision Date
New Release of QBLP613_series	V1.0	11/14/2011
Update to new format	V1.1	04/03/2012
Information Update	V1.2	10/25/2012
Amend the package dimension/ Amend the pad layout	V1.3	07/18/2013
Update Spec	V1.4	08/06/2013
Update IW, IG, and AG luminous intensity	V1.5	03/27/2014
Add orange color option	V1.6	10/23/2023



Disclaimer

QT-BRIGHTTEK reserves the right to make changes without further notice to any products herein to improve reliability, function or design. QT-BRIGHTTEK does not assume any liability arising out of the application or use of any product or circuit described herein; neither does it convey any license under its patent rights, nor the rights of others.

Life Support Policy

QT-BRIGHTTEK's products are not authorized for use as critical components in life support devices or systems without the express written approval of QT-BRIGHTTEK. As used herein:

1. Life support devices or systems are devices or systems which, (a) are intended for surgical implant into the body, or (b) support or sustain life, and (c) whose failure to perform when properly used in accordance with instructions for use provided in the labeling, can be reasonably expected to result in a significant injury of the user.
2. A critical component in any component of a life support device or system whose failure to perform can be reasonably expected to cause the failure of the life support device or system, or to affect its safety or effectiveness.