

- ROCKER SWITCH MODEL NO.SS21-RBIWG-L05-R
- QUICK CONNECTOR TYPE WITH LAMP-RoHs COMPLIANCE;
DOUBLE POLE SINGLE THROW
- RATING: RATING:10A 125/250VAC(C-UL)
12(4)A 250V~T85/55(ENEC17;NEMKO;CQC)

CUL APPROVAL FILE NO.E153399
ENEC17 CERTIFICATE NO.3704
NEMKO CERTIFICATE NO.P15219978
CQC CERTIFICATE NO.CQC10002046596
CB CERTIFICATE NO.87398
KC CERTIFICATE NO.SU02099-17001

- ACTUATOR COLOR:(PC) RED
- HOUSING COLOR: BLACK
- ACTUATOR PRINTING:" $\frac{1}{2}$ "WHITE COLOR
- ALL MATERIALS USING MEET THE RoHS DIRECTIVE

TEL: 0769-82310511-867

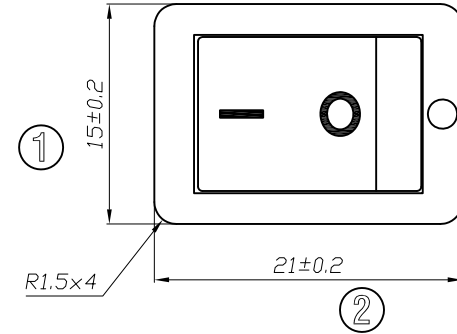
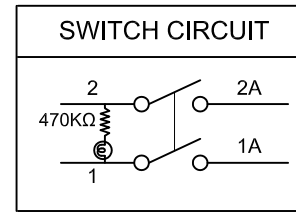

PANEL CUTOUT DIMENSION

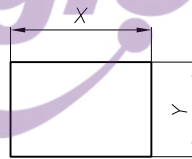

PANEL THICKNESS	X	Y
0.75~1.25mm	19.2 ⁺⁰ _{-0.1} mm	12.9 ^{+0.1} ₋₀ mm
1.25~2.0mm	19.4 ⁺⁰ _{-0.1} mm	12.9 ^{+0.1} ₋₀ mm
2.0~3.0mm	19.8 ⁺⁰ _{-0.1} mm	12.9 ^{+0.1} ₋₀ mm

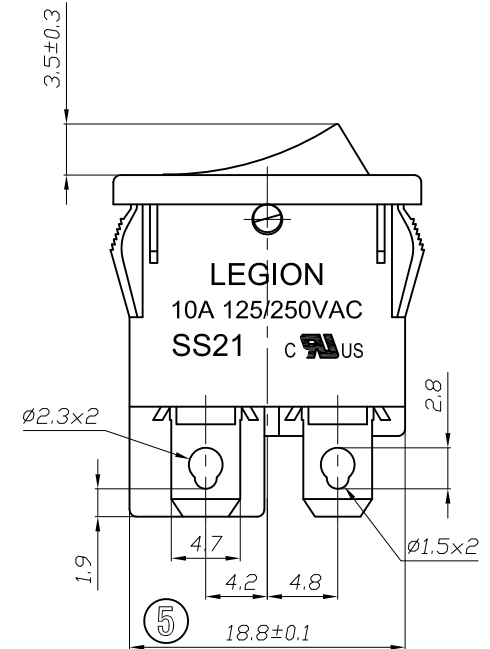
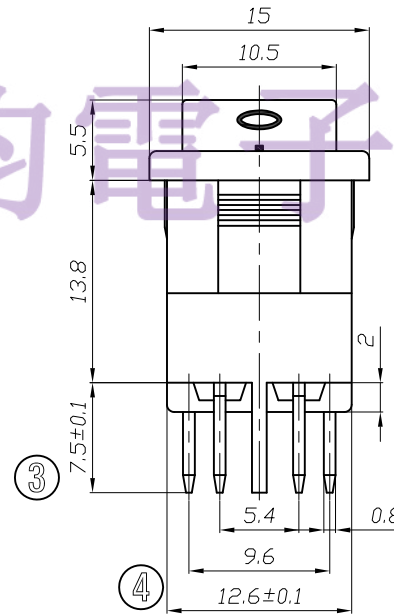
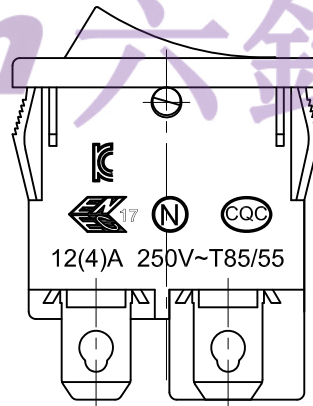

修正 REVISION	說明 DESCRIPTION	修訂者 REVISED BY	SPECIFICATION				公差 TOLERANCES		TOLERANCES UNLESS OTHERWISE SPEC.±0.3/0.05,ANG.±2°		
			製圖 DRAWN BY	設計 DESIGNED BY	校對 CHECKED BY	核准 APPROVED BY	單位 UNIT	mm	機種名稱 MODEL NAME	ROCKER SW	機種編號 MODEL NO.
△			管林华	刘美昌	刘美昌	刘美昌	比例 SCALE	1/1	六鈞電子五金有限公司 LEGION ELECTRONIC & HARDWARE CO., LTD.		
△			25-FEB-2017	25-FEB-2017	25-FEB-2017	25-FEB-2017	日期 DATE	2017.2.25			