

1. 跷板开关型号 ROCKER SWITCH MODEL NO.SS21-BBIWG-S1-A

2. 快插端子 QUICK CONNECTOR TYPE

3. 额定值 RATING:10A 125/250VAC(C-UL)

12(4)A 250V~T85/55(ENEC17;NEMKO;CQC;KC)

4. 柄的颜色 ACTUATOR COLOR:BLACK

5. 基座的颜色 HOUSING COLOR: BLACK

6. 柄的印字形式 ACTUATOR PRINTING:" 1/0 "白色 WHITE COLOR

7. 所有部件均使用环保材料

ALL MATERIALS USING MEET THE RoHS DIRECTIVE

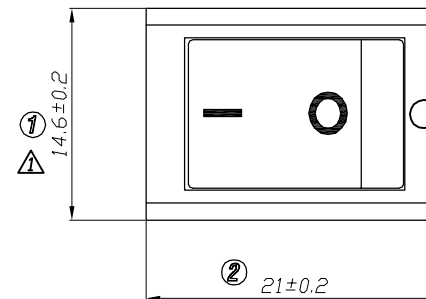
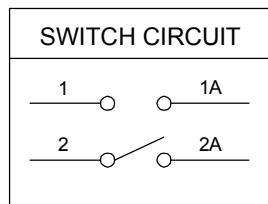

PANEL CUTOUT DIMENSION

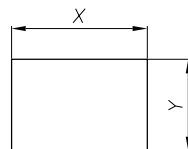

PANEL THICKNESS	X	Y
0.75~1.25mm	18.85 ^{+0.1} ₀ mm	12.75 ^{+0.1} ₀ mm
1.26~1.80mm	19.20 ^{+0.1} ₀ mm	12.75 ^{+0.1} ₀ mm
1.81~3.30mm	19.40 ^{+0.1} ₀ mm	12.75 ^{+0.1} ₀ mm

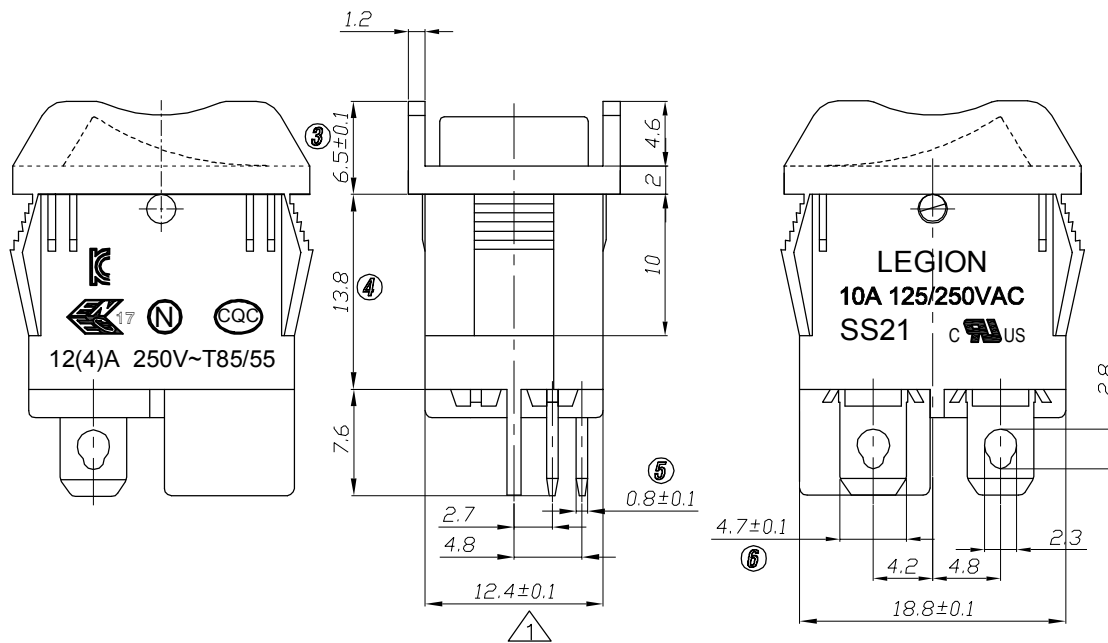

NO	DESCRIPTION	NO	DESCRIPTION	DIMENSIONAL TOLERANCES		APPROVED	CHECKED	DESIGN	DRAWN	ALL SIZE ARE IN		DRAWING NO. REV.	
				RANGE	TOLERANCE					MM	NO	DRAWING NO.	REV.
5	→	10	→										
4	→	9	→										
3	→	8	→	X	±0.30				LMC 2019.05.20	MAT'L	***		
2	→	7	→	X.X	±0.20					MATERIAL NO.			
1	12.6 → 12.4	6	→	X.XX	±0.10								
NO	DESCRIPTION	NO	DESCRIPTION	ANGLES	±1'	LEGION ELECTRONIC & HARDWARE CO., LTD.				SS21-BBIWG-S2-A	WIF119125	A1	