

1. 电路 CIRCUIT: ON/OFF
2. 快插端子 QUICK CONNECTOR TYPE
3. 额定值 RATING: 10A 125/250VAC(C-UL)  
12(4)A 250V~T85/55(ENEC17;NEMKO;CQC;KC)
4. 柄的颜色 ACTUATOR COLOR: BLACK
5. 基座的颜色 HOUSING COLOR: BLACK
6. 柄的印字形式 ACTUATOR PRINTING: " 1/2 "白色 WHITE COLOR
7. 所有部件均使用环保材料  
ALL MATERIALS USING MEET THE RoHS DIRECTIVE

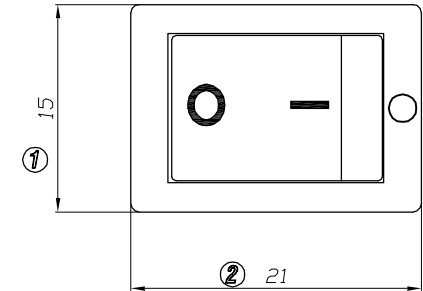

PANEL CUTOUT DIMENSION

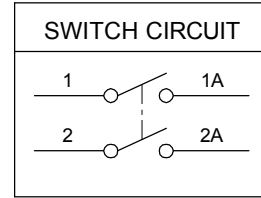
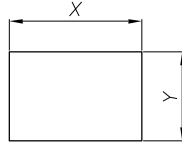

PANEL THICKNESS	X	Y
0.75~1.25mm	19.2 <sup>+0</sup> <sub>-0.1</sub> mm	12.9 <sup>+0.1</sup> <sub>-0</sub> mm
1.25~2.0mm	19.4 <sup>+0</sup> <sub>-0.1</sub> mm	12.9 <sup>+0.1</sup> <sub>-0</sub> mm
2.0~3.0mm	19.8 <sup>+0</sup> <sub>-0.1</sub> mm	12.9 <sup>+0.1</sup> <sub>-0</sub> mm

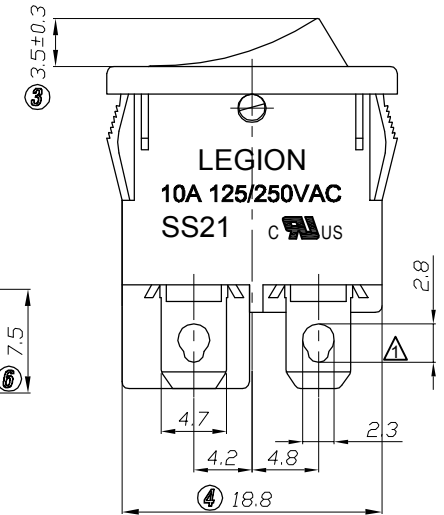
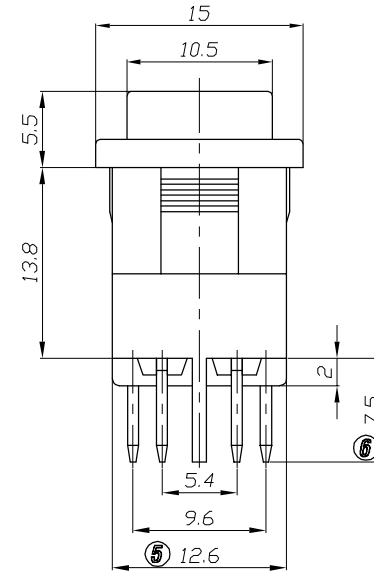
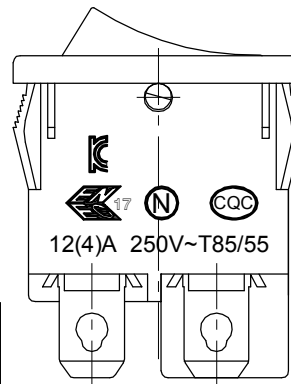

NO	DESCRIPTION	NO	DESCRIPTION	DIMENSIONAL TOLERANCES		APPROVED	CHECKED	DESIGN	DRAWN	ALL SIZE ARE IN		DRAWING NO.	REV.
				RANGE	TOLERANCE					MM	NO		
		10							LMC	SCALE	***		
		9		X	±0.30				2019.06.26	MAT'L			
		8		X.X	±0.20					MATERIAL NO.			
		7		X.XX	±0.10					SS21-BBIWG-D		WIF122036	A0
		6		ANGLES	±1'	LEGION ELECTRONIC & HARDWARE CO., LTD.							