

1. 电路CIRCUIT: ON/OFF;
2. 快插端子QUICK CONNECTOR TYPE;
单刀单掷 (SINGLE POLE DOUBLE THROW);
3. 额定值RATING: 16A 125/250VAC (UL;C-UL);
12A 125/250VAC (UL;C-UL);
10A 125/250VAC (UL;C-UL);
6A 125/250VAC (UL;C-UL);
16(4)A 250V~T125/55(ENEC17;NEMKO;CQC;CB)
12A 125/250V~T125/55(CQC)
10A 125/250V~T125/55(ENEC17;NEMKO;CQC;CB)
6A 125/250V~T125/55(ENEC17;NEMKO;CQC;CB)
4. 柄的颜色ACTUATOR COLOR: 灰色GREY
基座的颜色HOUSING COLOR: 灰色GREY
5. 柄的印字形式ACTUATOR PRINTING: 白色"O/-" WHITE COLOR
6. 所有部件均使用环保材料
ALL MATERIALS USE IN CONFORMIY WITH THE RoHS DIRECTIVE

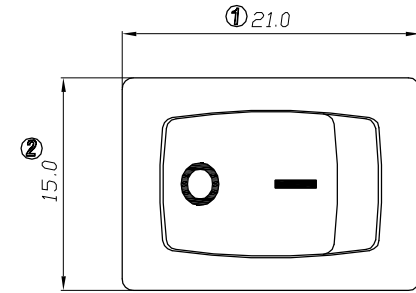

TEL: 0769-82310511-867

PANEL CUTOUT DIMENSION

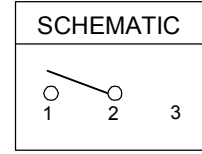
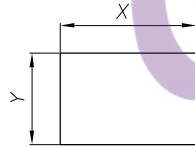

PANEL THICKNESS	X	Y
0.8~1.2mm	19.2 ⁺⁰ _{-0.1} mm	12.9 ^{+0.1} ₋₀ mm
1.3~2.0mm	19.4 ⁺⁰ _{-0.1} mm	12.9 ^{+0.1} ₋₀ mm
2.1~2.5mm	19.8 ⁺⁰ _{-0.1} mm	12.9 ^{+0.1} ₋₀ mm

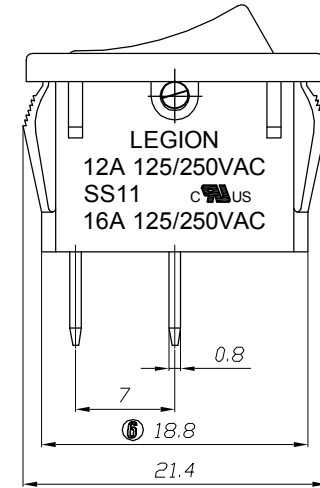
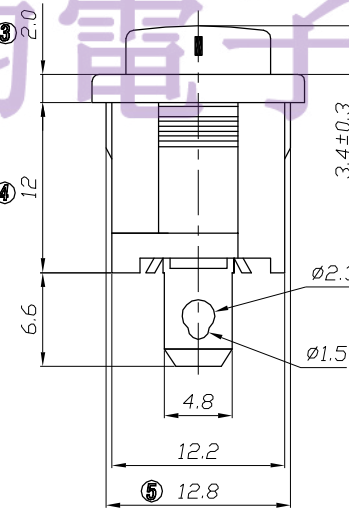
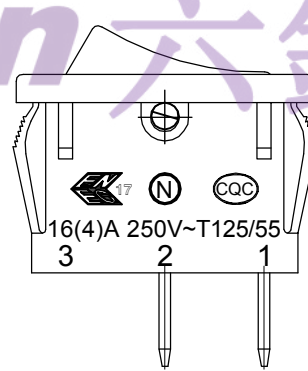

NO	DESCRIPTION	NO	DESCRIPTION	ANGLES	DIMENSIONAL TOLERANCES	APPROVED	CHECKED	DESIGN	DRAWN	ALL SIZE ARE IN	MM	DRAWING NO.	REV.
5	→	10	→		RANGE					SCALE	NO		
4	→	9	→		TOLERANCE				LMC	MAT'L	***		
3	→	8	→	X	X				2019.05.20	MATERIAL NO.			
2	→	7	→	X.X	±0.30								
1	→	6	→	X.XX	±0.20								
					±0.10	LEGION ELECTRONIC & HARDWARE CO., LTD.				SS11-EEIWG-R20-R			
					±1°								

