

- 1.CIRCUIT:ON/OFF
- 2.RATING: 3A 125/250VAC  
6(1)A 250V~ T125/55(ENEC17;NEMKO)
- 3.CONTACT RESISTANT: <50mΩ (INITIAL)
- 4.INSULATION RESISTANCE: >100MΩ  
(500VDC BETWEEN OPEN CONTACTS)
- 5.DIELECTRIC STRENGTH: 1500V 1MIN
- 6.ACTUATOR & HOUSING COLOR: WHITE
- 7.ACTUATOR PRINTING COLOR: BLACK

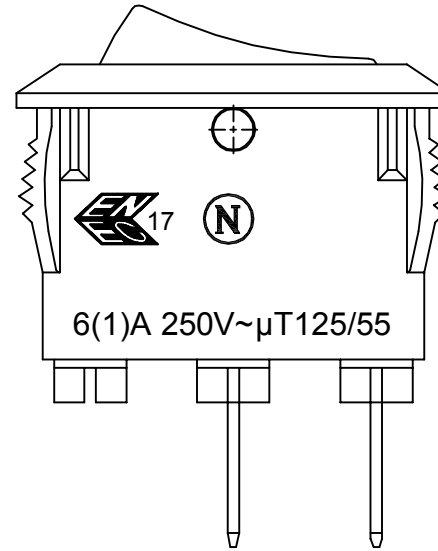

	X Cutout Dimension	Panel Thickness
A	13.5 - 13.6	0.75~1.25
B	13.6 - 13.7	1.25~2.00

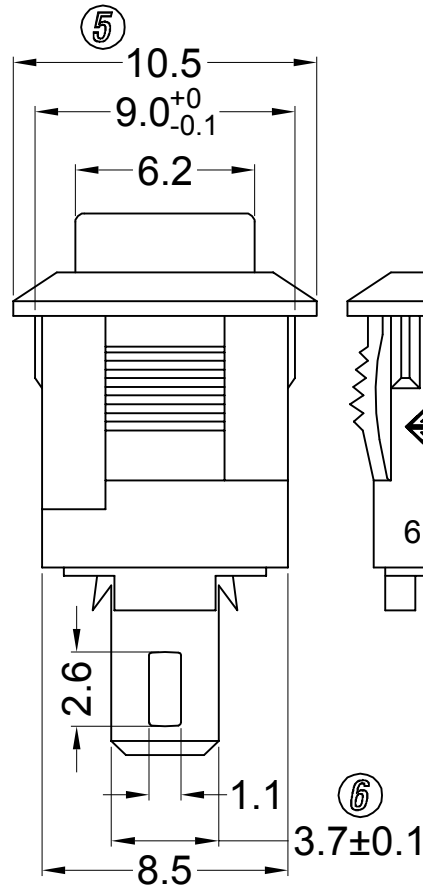
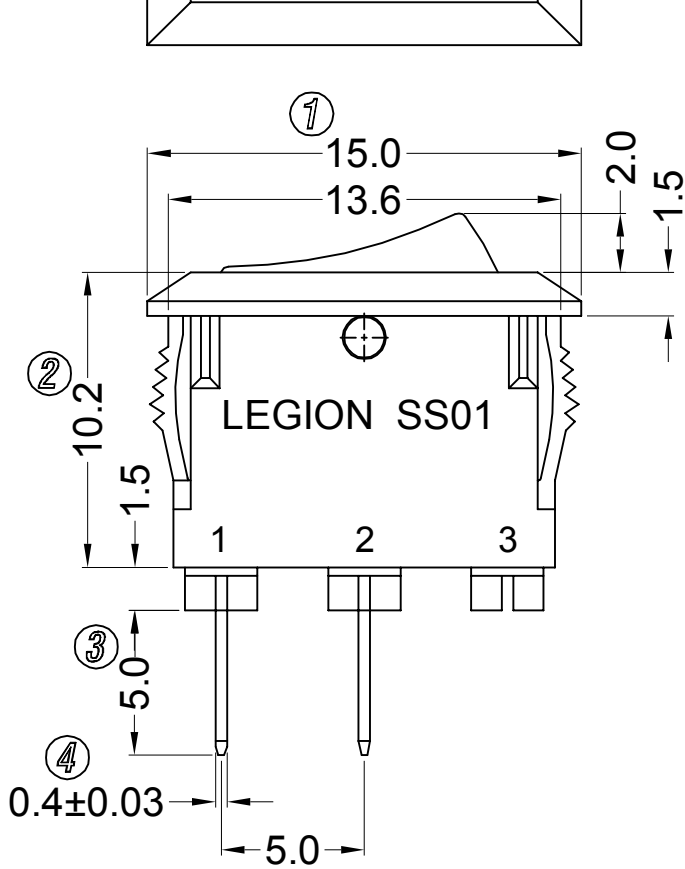
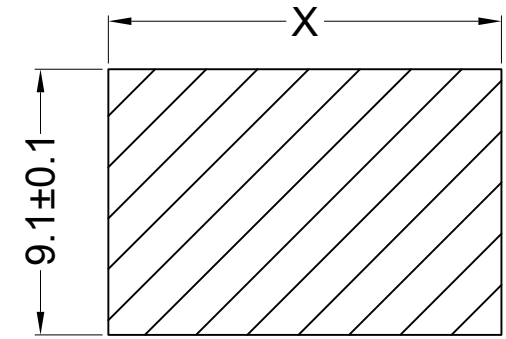

MOUNTING HOLE

5	→			GENERAL TOLERANCE	Approved	Checked	Designed	Drawn	ALL SIZE ARE IN	mm		
4	→			GRADATION					SCALE			
3	→			X.					MAT' L			
2	→			X.X					ORDER NO.	DRAWING NO.		REV.
1	→			X.XXX					SS01-WWIBA-RA20-R	*****		A
NO.	DESCRIPTION	APPROVED	DATE	ANGLE	六鈞電子五金有限公司 LEGION ELECTRONIC & HARDWARE CO., LTD.							