



灵星芯微 芯片经营

深圳市灵星芯微电子科技有限公司

Shenzhen Lingxing Microelectronics Technology Co., Ltd.

Tab: 835-12-B4

Number:SN74LS153-AX-LJ-A056EN

# SN74LS153 (LX) Dual 4-input Multiplexer

## Product Specification

### Specification Revision History:

Version	Date	Description
2021-06-A1	2021-06	New
2023-04-B1	2023-04	Update the template



# Contents

<b>1、 General Description.....</b>	<b>3</b>
<b>2、 Block Diagram And Pin Description .....</b>	<b>6</b>
2.1、 Block Diagram .....	6
2.2、 Pin Configurations.....	7
2.3、 Pin Description .....	7
2.4、 Function Table.....	7
<b>3、 Electrical Parameter .....</b>	<b>8</b>
3.1、 Absolute Maximum Ratings.....	8
3.2、 Recommended Operating Conditions .....	8
3.3、 Electrical Characteristics .....	9
3.3.1、 DC Characteristics 1 .....	9
3.3.2、 DC Characteristics 2 .....	10
3.3.3、 DC Characteristics 3 .....	11
3.3.4、 AC Characteristics 1 .....	12
3.3.5、 AC Characteristics 2 .....	13
3.3.6、 AC Characteristics 3 .....	14
<b>4、 Testing Circuit .....</b>	<b>15</b>
4.1、 AC Testing Circuit .....	15
4.2、 AC Testing Waveforms.....	15
4.3、 Measurement Points .....	16
4.4、 Test Data .....	16
<b>5、 Package Information .....</b>	<b>17</b>
5.1、 DIP16 .....	17
5.2、 SOP16 .....	18
5.3、 TSSOP16.....	19
<b>6、 Statements And Notes .....</b>	<b>20</b>
6.1、 The name and content of Hazardous substances or Elements in the product .....	20
6.2、 Notes .....	20



灵星芯微 集成电路

## 1、General Description

The SN74LS153 is a dual 4-input multiplexer. The device features independent enable inputs ( $\bar{nE}$ ) and common data select inputs (S0 and S1). For each multiplexer, the select inputs select one of the four binary inputs and routes it to the multiplexer output ( $nY$ ). A HIGH on  $\bar{E}$  forces the corresponding multiplexer outputs LOW. Inputs include clamp diodes. This enables the use of current limiting resistors to interface inputs to voltages in excess of  $V_{CC}$ .

### Features:

- Non-inverting outputs
- Separate enable input for each output
- Common select inputs
- Permits multiplexing from n lines to 1 line
- Enable line provided for cascading (n lines to 1 line)
- Specified from -40°C to +125°C
- Packaging information: DIP16/SOP16/TSSOP16



**Ordering Information:**

**Tube packing specifications:**

Part number	Packaging form	Marking code	Tube quantity	Boxed tube quantity	Boxed quantity	Notes
SN74LS153N(LX)	DIP16	SN74LS153N	25 PCS/tube	40 tube/box	1000 PCS/box	Dimensions of plastic enclosure: 19.0mm×6.4mm Pin spacing: 2.54mm
SN74LS153DR(LX)	SOP16	LS153	50 PCS/tube	200 tube/box	10000 PCS/box	Dimensions of plastic enclosure: 10.0mm×3.9mm Pin spacing: 1.27mm
SN74LS153PW(LX)	TSSOP16	LS153	96 PCS/tube	200 tube/box	19200 PCS/box	Dimensions of plastic enclosure: 5.0mm×4.4mm Pin spacing: 0.65mm



灵星芯微 集成电路

深圳市灵星芯微电子科技有限公司

Shenzhen Lingxing Microelectronics Technology Co., Ltd.

Tab: 835-12-B4

Number:SN74LS153-AX-LJ-A056EN

**Reel packing specifications:**

Part number	Packaging form	Marking code	Reel quantity	Boxed reel quantity	Notes
SN74LS153DR(LX)	SOP16	LS153	2500 PCS/reel	5000 PCS/box	Dimensions of plastic enclosure: 10.0mm×3.9mm Pin spacing:1.27mm
SN74LS153PW(LX)	TSSOP16	LS153	5000 PCS/reel	10000 PCS/box	Dimensions of plastic enclosure: 5.0mm×4.4mm Pin spacing:0.65mm

Note: If the physical information is inconsistent with the ordering information, please refer to the actual product.



## 2、Block Diagram And Pin Description

### 2.1、Block Diagram

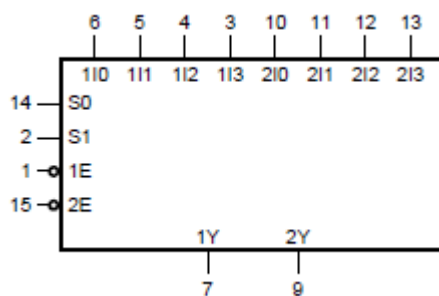

Figure 1. Logic symbol

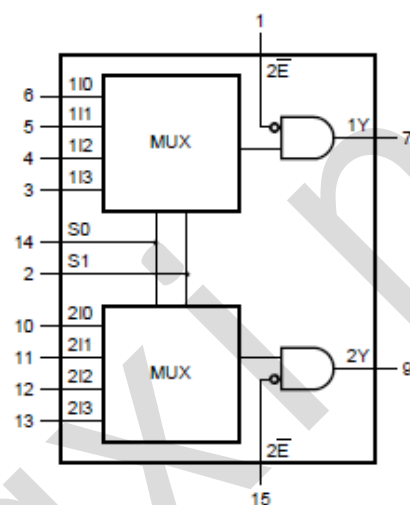

Figure 2. Functional diagram

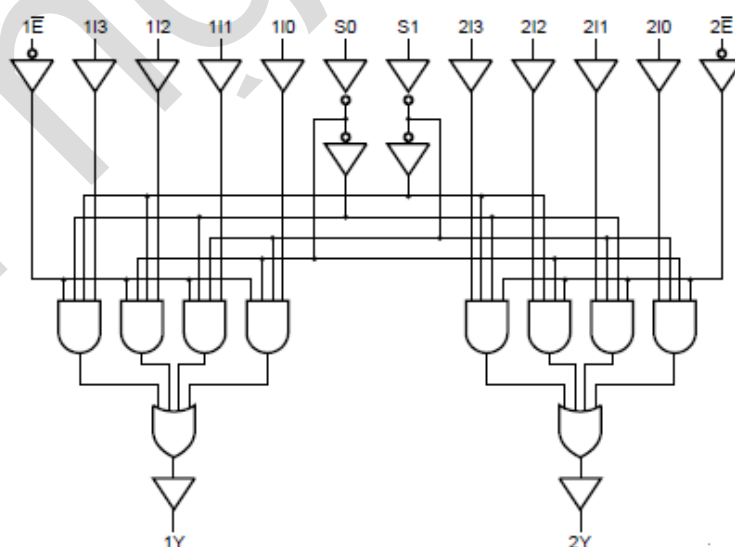
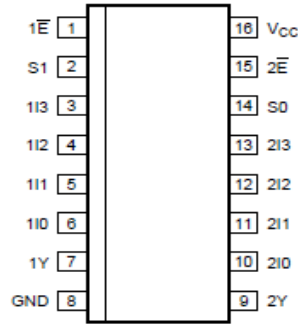

Figure 3. Logic diagram



## 2.2、Pin Configurations



## 2.3、Pin Description

Pin No.	Pin Name	Description
1	$\overline{1E}$	output enable input (active LOW)
2	S1	data select input
3	I13	data input source 1
4	I12	data input source 1
5	I11	data input source 1
6	I10	data input source 1
7	1Y	multiplexer output source 1
8	GND	ground (0V)
9	2Y	multiplexer output source 2
10	2I0	data input source 2
11	2I1	data input source 2
12	2I2	data input source 2
13	2I3	data input source 2
14	S0	data select input
15	$\overline{2E}$	output enable input (active LOW)
16	V <sub>CC</sub>	supply voltage

## 2.4、Function Table

Select Input		Input				Output Enable	Output
S0	S1	nI0	nI1	nI2	nI3	$\overline{nE}$	nY
X	X	X	X	X	X	H	L
L	L	L	X	X	X	L	L
L	L	H	X	X	X	L	H
H	L	X	L	X	X	L	L
H	L	X	H	X	X	L	H
L	H	X	X	L	X	L	L
L	H	X	X	H	X	L	H
H	H	X	X	X	L	L	L
H	H	X	X	X	H	L	H

Note: H=HIGH voltage level; L=LOW voltage level; X=don't care.



### 3、Electrical Parameter

#### 3.1、Absolute Maximum Ratings

(Voltages are referenced to GND(ground=0V), unless otherwise specified.)

Parameter	Symbol	Conditions	Min.	Max.	Unit
supply voltage	$V_{CC}$	-	-0.5	+7.0	V
input clamping current	$I_{IK}$	$V_I < -0.5V$ or $V_I > V_{CC}+0.5V$	-	$\pm 20$	mA
output clamping current	$I_{OK}$	$V_O < -0.5V$ or $V_O > V_{CC}+0.5V$	-	$\pm 20$	mA
output current	$I_O$	$-0.5V < V_O < V_{CC}+0.5V$	-	$\pm 25$	mA
supply current	$I_{CC}$	-	-	50	mA
ground current	$I_{GND}$	-	-50	-	mA
storage temperature	$T_{stg}$	-	-65	+150	$^{\circ}C$
total power dissipation	$P_{tot}$	-	-	500	mW
soldering temperature	$T_L$	10s	DIP	245	$^{\circ}C$
			SOP/TSSOP	260	

#### 3.2、Recommended Operating Conditions

Parameter	Symbol	Conditions	Min.	Typ.	Max.	Unit
supply voltage	$V_{CC}$	-	2.0	5.0	6.0	V
input voltage	$V_I$	-	0	-	$V_{CC}$	V
output voltage	$V_O$	-	0	-	$V_{CC}$	V
input transition rise and fall rate	$\Delta t/\Delta V$	$V_{CC}=2.0V$	-	-	625	ns/V
		$V_{CC}=4.5V$	-	1.67	139	ns/V
		$V_{CC}=6.0V$	-	-	83	ns/V
ambient temperature	$T_{amb}$	-	-40	-	+125	$^{\circ}C$





### 3.3、Electrical Characteristics

#### 3.3.1、DC Characteristics 1

( $T_{amb}=25^{\circ}\text{C}$ , voltages are referenced to GND (ground=0V), unless otherwise specified.)

Parameter	Symbol	Conditions	Min.	Typ.	Max.	Unit	
HIGH-level input voltage	$V_{IH}$	$V_{CC}=2.0\text{V}$	1.5	1.2	-	V	
		$V_{CC}=4.5\text{V}$	3.15	2.4	-	V	
		$V_{CC}=6.0\text{V}$	4.2	3.2	-	V	
LOW-level input voltage	$V_{IL}$	$V_{CC}=2.0\text{V}$	-	0.8	0.5	V	
		$V_{CC}=4.5\text{V}$	-	2.1	1.35	V	
		$V_{CC}=6.0\text{V}$	-	2.8	1.8	V	
HIGH-level output voltage	$V_{OH}$	$V_I=V_{IH}$ or $V_{IL}$	$I_O=-20\mu\text{A}; V_{CC}=2.0\text{V}$	1.9	2.0	-	V
			$I_O=-20\mu\text{A}; V_{CC}=4.5\text{V}$	4.4	4.5	-	V
			$I_O=-20\mu\text{A}; V_{CC}=6.0\text{V}$	5.9	6.0	-	V
			$I_O=-4.0\text{mA}; V_{CC}=4.5\text{V}$	3.98	4.32	-	V
			$I_O=-5.2\text{mA}; V_{CC}=6.0\text{V}$	5.48	5.81	-	V
LOW-level output voltage	$V_{OL}$	$V_I=V_{IH}$ or $V_{IL}$	$I_O=20\mu\text{A}; V_{CC}=2.0\text{V}$	-	0	0.1	V
			$I_O=20\mu\text{A}; V_{CC}=4.5\text{V}$	-	0	0.1	V
			$I_O=20\mu\text{A}; V_{CC}=6.0\text{V}$	-	0	0.1	V
			$I_O=4.0\text{mA}; V_{CC}=4.5\text{V}$	-	0.15	0.26	V
			$I_O=5.2\text{mA}; V_{CC}=6.0\text{V}$	-	0.16	0.26	V
input leakage current	$I_I$	$V_I=V_{CC}$ or GND; $V_{CC}=6.0\text{V}$	-	-	$\pm 1.0$	$\mu\text{A}$	
supply current	$I_{CC}$	$V_I=V_{CC}$ or GND; $I_O=0\text{A}; V_{CC}=6.0\text{V}$	-	-	8.0	$\mu\text{A}$	
input capacitance	$C_I$	-	-	3.5	-	pF	



### 3.3.2、DC Characteristics 2

( $T_{amb}=-40^{\circ}\text{C}$  to  $+85^{\circ}\text{C}$ , voltages are referenced to GND (ground=0V), unless otherwise specified.)

Parameter	Symbol	Conditions	Min.	Typ.	Max.	Unit	
HIGH-level input voltage	$V_{IH}$	$V_{CC}=2.0\text{V}$	1.5	-	-	V	
		$V_{CC}=4.5\text{V}$	3.15	-	-	V	
		$V_{CC}=6.0\text{V}$	4.2	-	-	V	
LOW-level input voltage	$V_{IL}$	$V_{CC}=2.0\text{V}$	-	-	0.5	V	
		$V_{CC}=4.5\text{V}$	-	-	1.35	V	
		$V_{CC}=6.0\text{V}$	-	-	1.8	V	
HIGH-level output voltage	$V_{OH}$	$V_I=V_{IH}$ or $V_{IL}$	$I_O=-20\mu\text{A}; V_{CC}=2.0\text{V}$	1.9	-	-	V
			$I_O=-20\mu\text{A}; V_{CC}=4.5\text{V}$	4.4	-	-	V
			$I_O=-20\mu\text{A}; V_{CC}=6.0\text{V}$	5.9	-	-	V
			$I_O=-4.0\text{mA}; V_{CC}=4.5\text{V}$	3.84	-	-	V
			$I_O=-5.2\text{mA}; V_{CC}=6.0\text{V}$	5.34	-	-	V
LOW-level output voltage	$V_{OL}$	$V_I=V_{IH}$ or $V_{IL}$	$I_O=20\mu\text{A}; V_{CC}=2.0\text{V}$	-	-	0.1	V
			$I_O=20\mu\text{A}; V_{CC}=4.5\text{V}$	-	-	0.1	V
			$I_O=20\mu\text{A}; V_{CC}=6.0\text{V}$	-	-	0.1	V
			$I_O=4.0\text{mA}; V_{CC}=4.5\text{V}$	-	-	0.33	V
			$I_O=5.2\text{mA}; V_{CC}=6.0\text{V}$	-	-	0.33	V
input leakage current	$I_I$	$V_I=V_{CC}$ or GND; $V_{CC}=6.0\text{V}$	-	-	$\pm 1.0$	$\mu\text{A}$	
supply current	$I_{CC}$	$V_I=V_{CC}$ or GND; $I_O=0\text{A}; V_{CC}=6.0\text{V}$	-	-	80	$\mu\text{A}$	



### 3.3.3、DC Characteristics 3

( $T_{amb} = -40^{\circ}\text{C}$  to  $+125^{\circ}\text{C}$ , voltages are referenced to GND (ground=0V), unless otherwise specified.)

Parameter	Symbol	Conditions	Min.	Typ.	Max.	Unit	
HIGH-level input voltage	$V_{IH}$	$V_{CC}=2.0\text{V}$	1.5	-	-	V	
		$V_{CC}=4.5\text{V}$	3.15	-	-	V	
		$V_{CC}=6.0\text{V}$	4.2	-	-	V	
LOW-level input voltage	$V_{IL}$	$V_{CC}=2.0\text{V}$	-	-	0.5	V	
		$V_{CC}=4.5\text{V}$	-	-	1.35	V	
		$V_{CC}=6.0\text{V}$	-	-	1.8	V	
HIGH-level output voltage	$V_{OH}$	$V_I = V_{IH}$ or $V_{IL}$	$I_O = -20\mu\text{A}; V_{CC} = 2.0\text{V}$	1.9	-	-	V
			$I_O = -20\mu\text{A}; V_{CC} = 4.5\text{V}$	4.4	-	-	V
			$I_O = -20\mu\text{A}; V_{CC} = 6.0\text{V}$	5.9	-	-	V
			$I_O = -4.0\text{mA}; V_{CC} = 4.5\text{V}$	3.7	-	-	V
			$I_O = -5.2\text{mA}; V_{CC} = 6.0\text{V}$	5.2	-	-	V
LOW-level output voltage	$V_{OL}$	$V_I = V_{IH}$ or $V_{IL}$	$I_O = 20\mu\text{A}; V_{CC} = 2.0\text{V}$	-	-	0.1	V
			$I_O = 20\mu\text{A}; V_{CC} = 4.5\text{V}$	-	-	0.1	V
			$I_O = 20\mu\text{A}; V_{CC} = 6.0\text{V}$	-	-	0.1	V
			$I_O = 4.0\text{mA}; V_{CC} = 4.5\text{V}$	-	-	0.4	V
			$I_O = 5.2\text{mA}; V_{CC} = 6.0\text{V}$	-	-	0.4	V
input leakage current	$I_I$	$V_I = V_{CC}$ or GND; $V_{CC} = 6.0\text{V}$	-	-	$\pm 1.0$	$\mu\text{A}$	
supply current	$I_{CC}$	$V_I = V_{CC}$ or GND; $I_O = 0\text{A}; V_{CC} = 6.0\text{V}$	-	-	160	$\mu\text{A}$	



### 3.3.4、AC Characteristics 1

( $T_{amb}=25^{\circ}C$ ,  $GND=0V$ ,  $t_r=t_f=6ns$ ;  $C_L=50pF$ , unless otherwise specified.)

Parameter	Symbol	Conditions	Min.	Typ.	Max.	Unit	
propagation delay	$t_{pd}$	1In to nY, 2In to nY; see Figure 5 <sup>[1]</sup>	$V_{CC}=2.0V$	-	47	145	ns
			$V_{CC}=4.5V$	-	17	29	ns
			$V_{CC}=5.0V$ ; $C_L=15pF$	-	14	-	ns
			$V_{CC}=6.0V$	-	14	25	ns
		Sn to nY; see Figure 6	$V_{CC}=2.0V$	-	50	150	ns
			$V_{CC}=4.5V$	-	18	30	ns
			$V_{CC}=5.0V$ ; $C_L=15pF$	-	15	-	ns
			$V_{CC}=6.0V$	-	14	26	ns
		nE to nY; see Figure 6	$V_{CC}=2.0V$	-	33	100	ns
			$V_{CC}=4.5V$	-	12	20	ns
			$V_{CC}=5.0V$ ; $C_L=15pF$	-	10	-	ns
			$V_{CC}=6.0V$	-	10	17	ns
transition time	$t_t$	see Figure 5 <sup>[2]</sup>	$V_{CC}=2.0V$	-	19	75	ns
			$V_{CC}=4.5V$	-	7	15	ns
			$V_{CC}=6.0V$	-	6	13	ns
power dissipation capacitance	$C_{PD}$	per package; $V_I=GND$ to $V_{CC}$ <sup>[3]</sup>	-	30	-	pF	

Note:

[1]  $t_{pd}$  is the same as  $t_{PLH}$  and  $t_{PHL}$ .

[2]  $t_t$  is the same as  $t_{THL}$  and  $t_{TLH}$ .

[3]  $C_{PD}$  is used to determine the dynamic power dissipation ( $P_D$  in uW).

$P_D=C_{PD} \times V_{CC}^2 \times f_i \times N + \sum(C_L \times V_{CC}^2 \times f_o)$  where:

$f_i$ =input frequency in MHz;  $f_o$ =output frequency in MHz;

$C_L$ =output load capacitance in pF;

$V_{CC}$ =supply voltage in V;

$N$ =number of inputs switching;

$\sum(C_L \times V_{CC}^2 \times f_o)$ =sum of outputs.



### 3.3.5、AC Characteristics 2

( $T_{amb}=-40^{\circ}\text{C}$  to  $+85^{\circ}\text{C}$ ,  $\text{GND}=0\text{V}$ ,  $t_r=t_f=6\text{ns}$ ;  $C_L=50\text{pF}$ , unless otherwise specified.)

Parameter	Symbol	Conditions	Min.	Typ.	Max.	Unit	
propagation delay	$t_{pd}$	1In to nY, 2In to nY; see Figure 5 <sup>[1]</sup>	$V_{CC}=2.0\text{V}$	-	-	180	ns
			$V_{CC}=4.5\text{V}$	-	-	36	ns
			$V_{CC}=6.0\text{V}$	-	-	31	ns
		Sn to nY; see Figure 6	$V_{CC}=2.0\text{V}$	-	-	190	ns
			$V_{CC}=4.5\text{V}$	-	-	38	ns
			$V_{CC}=6.0\text{V}$	-	-	33	ns
		$\bar{nE}$ to nY; see Figure 6	$V_{CC}=2.0\text{V}$	-	-	125	ns
			$V_{CC}=4.5\text{V}$	-	-	25	ns
			$V_{CC}=6.0\text{V}$	-	-	21	ns
transition time	$t_t$	see Figure 5 <sup>[2]</sup>	$V_{CC}=2.0\text{V}$	-	-	95	ns
			$V_{CC}=4.5\text{V}$	-	-	19	ns
			$V_{CC}=6.0\text{V}$	-	-	16	ns

Note:

[1]  $t_{pd}$  is the same as  $t_{PLH}$  and  $t_{PHL}$ .

[2]  $t_t$  is the same as  $t_{THL}$  and  $t_{TLH}$ .



### 3.3.6、AC Characteristics 3

( $T_{amb}=-40^{\circ}\text{C}$  to  $+125^{\circ}\text{C}$ ,  $\text{GND}=0\text{V}$ ,  $t_r=t_f=6\text{ns}$ ;  $C_L=50\text{pF}$ , unless otherwise specified.)

Parameter	Symbol	Conditions	Min.	Typ.	Max.	Unit	
propagation delay	$t_{pd}$	1In to nY, 2In to nY; see Figure 5 <sup>[1]</sup>	$V_{CC}=2.0\text{V}$	-	-	220	ns
			$V_{CC}=4.5\text{V}$	-	-	44	ns
			$V_{CC}=6.0\text{V}$	-	-	38	ns
		Sn to nY; see Figure 6	$V_{CC}=2.0\text{V}$	-	-	225	ns
			$V_{CC}=4.5\text{V}$	-	-	45	ns
			$V_{CC}=6.0\text{V}$	-	-	38	ns
		$\bar{nE}$ to nY; see Figure 6	$V_{CC}=2.0\text{V}$	-	-	150	ns
			$V_{CC}=4.5\text{V}$	-	-	30	ns
			$V_{CC}=6.0\text{V}$	-	-	26	ns
transition time	$t_t$	see Figure 5 <sup>[2]</sup>	$V_{CC}=2.0\text{V}$	-	-	110	ns
			$V_{CC}=4.5\text{V}$	-	-	22	ns
			$V_{CC}=6.0\text{V}$	-	-	19	ns

Note:

[1]  $t_{pd}$  is the same as  $t_{PLH}$  and  $t_{PHL}$ .

[2]  $t_t$  is the same as  $t_{THL}$  and  $t_{TLH}$ .

## 4、Testing Circuit

### 4.1、AC Testing Circuit

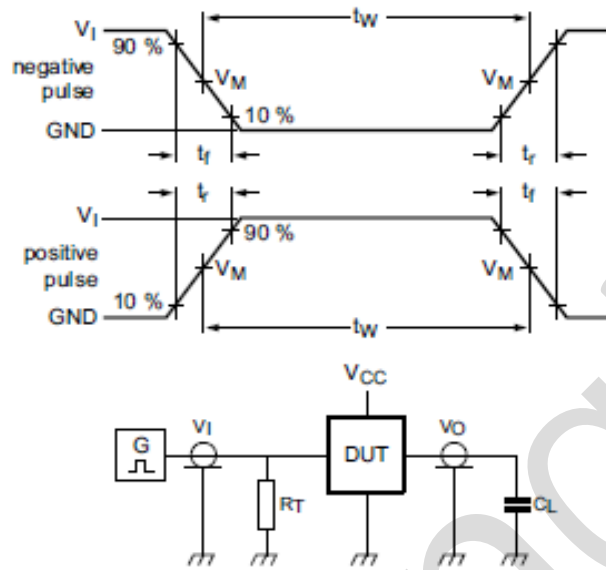

Figure 4. Test circuit for measuring switching times

Definitions for test circuit:

$C_L$ =Load capacitance including jig and probe capacitance.

$R_T$ =Termination resistance should be equal to the output impedance  $Z_o$  of the pulse generator.

### 4.2、AC Testing Waveforms

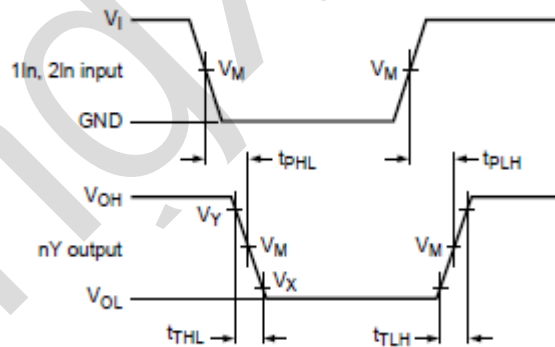

Figure 5. Waveforms showing the input (1In, 2In) to output (1Y, 2Y) propagation delays and output transition times

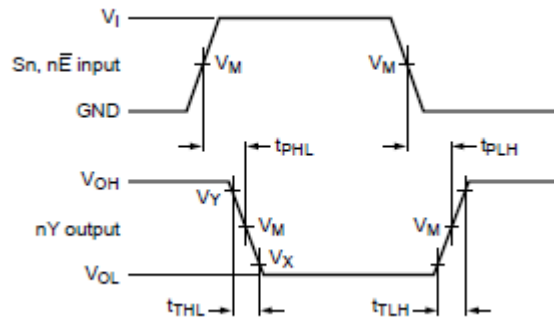

Figure 6. Waveforms showing the input (Sn, nE) to output (nY) propagation delays

#### 4.3. Measurement Points

Input	Output		
$V_M$	$V_M$	$V_X$	$V_Y$
$0.5 \times V_{CC}$	$0.5 \times V_{CC}$	$0.1 \times V_{CC}$	$0.9 \times V_{CC}$

#### 4.4. Test Data

Input		Load	Test
$V_I$	$t_r, t_f$	$C_L$	
$V_{CC}$	6ns	15pF, 50pF	$t_{PHL}, t_{PLH}$





灵星芯微 专注经营

## 5、Package Information

### 5.1、DIP16

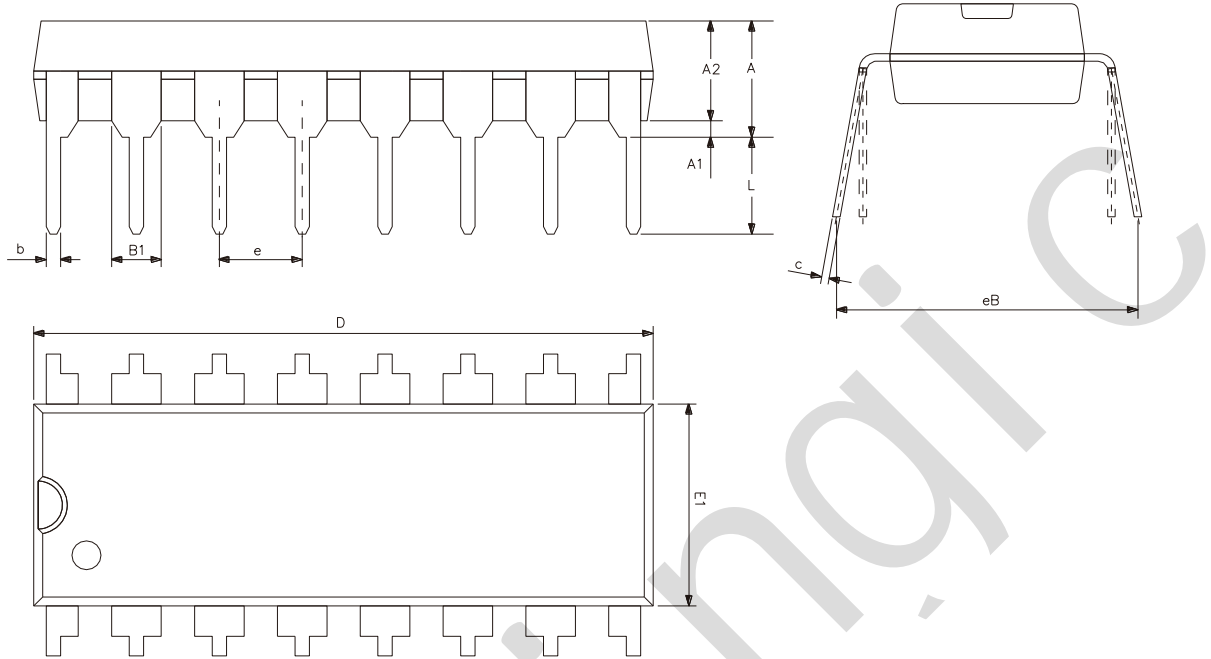

Symbol	Dimensions (mm)	
	Min.	Max.
A2	3.20	3.60
A1	0.51	-
A	3.60	5.33
L	3.00	3.60
b	0.36	0.56
B1	1.52	
D	18.80	19.94
E1	6.20	6.60
e	2.54	
c	0.20	0.36
eB	7.62	9.30



## 5.2、SOP16

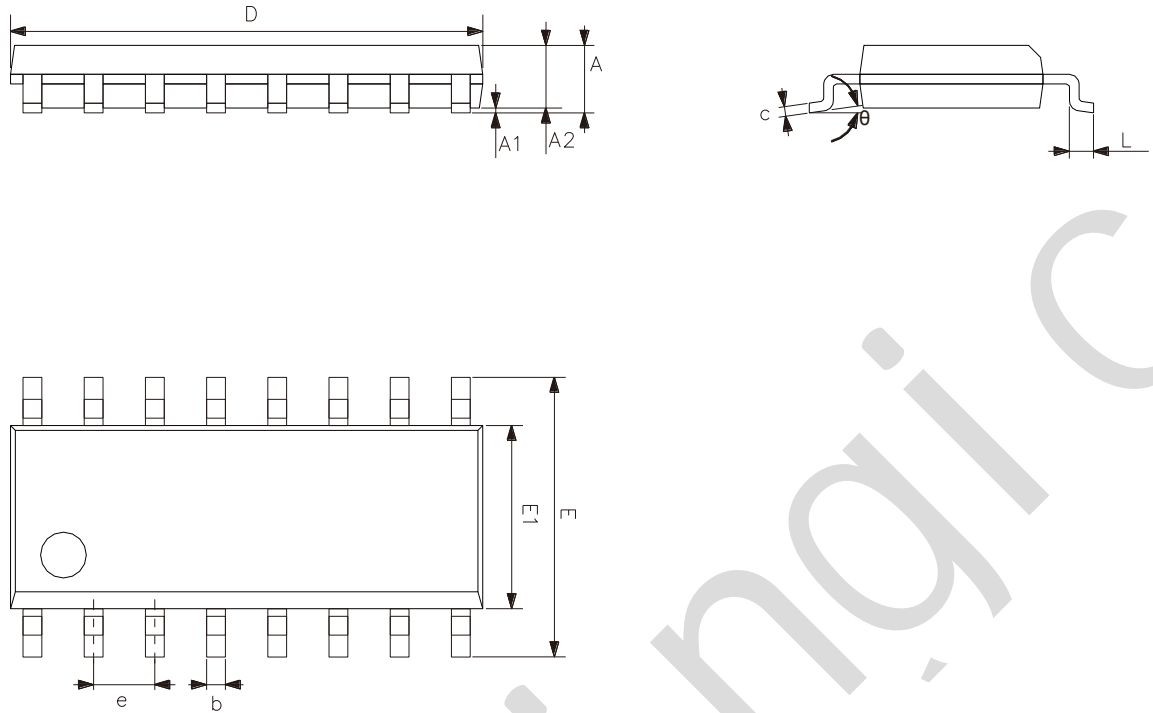

Symbol	Dimensions (mm)	
	Min.	Max.
A	1.35	1.80
A1	0.10	0.25
A2	1.25	1.55
b	0.33	0.51
c	0.19	0.25
D	9.50	10.10
E	5.80	6.30
E1	3.70	4.10
e	1.27	
L	0.35	0.89
$\theta$	0°	8°



灵星芯微 专注经营

### 5.3、TSSOP16

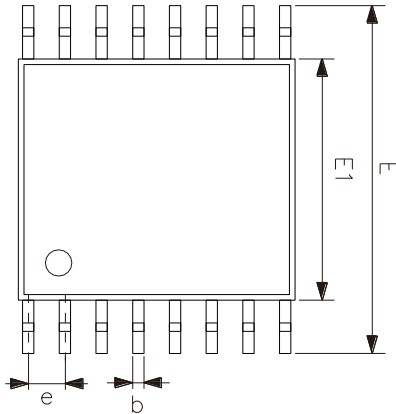
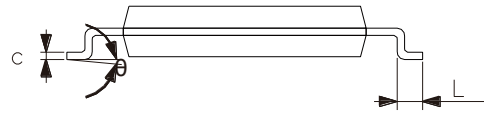
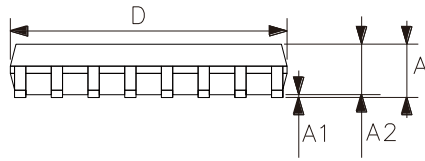

Symbol	Dimensions (mm)	
	Min.	Max.
A	-	1.20
A1	0.05	0.15
A2	0.80	1.05
b	0.19	0.30
c	0.09	0.20
D	4.90	5.10
E1	4.30	4.50
E	6.20	6.60
e	0.65	
L	0.45	0.75
$\theta$	0°	8°



## 6、 Statements And Notes

### 6.1、 The name and content of Hazardous substances or Elements in the product

Part name	Hazardous substances or Elements									
	Lead and lead compounds	Mercury and mercury compounds	Cadmium and cadmium compounds	Hexavalent chromium compounds	Polybrominated biphenyls	Polybrominated biphenyl ethers	Dibutyl phthalate	Butylbenzyl phthalate	Di-2-ethylhexyl phthalate	Diisobutyl phthalate
Lead frame	○	○	○	○	○	○	○	○	○	○
Plastic resin	○	○	○	○	○	○	○	○	○	○
Chip	○	○	○	○	○	○	○	○	○	○
The lead	○	○	○	○	○	○	○	○	○	○
Plastic sheet installed	○	○	○	○	○	○	○	○	○	○
explanation	○: Indicates that the content of hazardous substances or elements in the detection limit of the following the SJ/T11363-2006 standard. ×: Indicates that the content of hazardous substances or elements exceeding the SJ/T11363-2006 Standard limit requirements.									

### 6.2、 Notes

We Recommend you to read this chapter carefully before using this product.

The information in this chapter is provided for reference only and lingxing disclaims any express or implied warranties, including but not limited to applicability, special application or non-infringement of third party rights.

This product is not suitable for critical equipment such as life-saving, life-sustaining or safety equipment. It is also not suitable for applications that may result in personal injury, death, or serious property or environmental damage due to product malfunction or failure. Lingxing will not be liable for any damages incurred by the customers at their own risk for such applications.

The customer is responsible for conducting all necessary tests lingxing's application to avoid failure in the application or the application of the customer's third party users. Lingxing does not accept any liability.

The Company reserves the right to change or improve the information published in this chapter at any time. The information in this chapter are subject to change without notice. We recommend the customer to consult our sales staff before purchasing.

Please obtain related materials form lingxing's regular channels and we are not responsible for its content if it is provided by sources other than our company.

In case of any conflict between the Chinese and English version, the version is subject to the Chinese one.