

1mm Pitch Connectors for Vertical Connection

FX5 Series

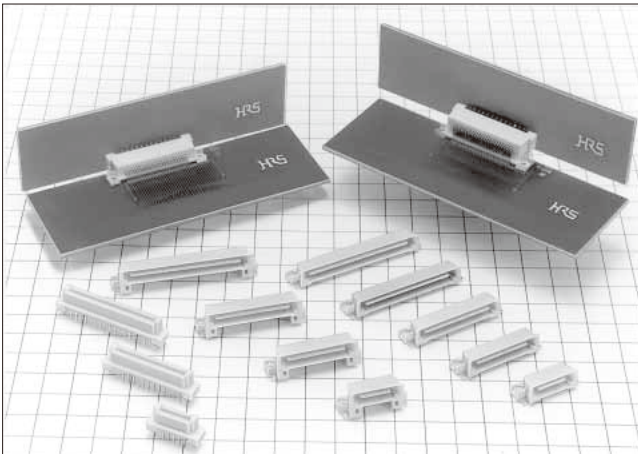

Connecting Height: Low profile

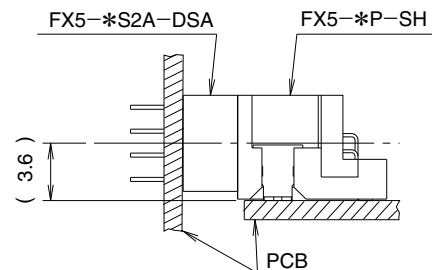

Fig.1

■ Features

1. Header Side : 2 Types Available

Two header types are available, low and high profiles. Combined with various contact positions, the FX5 is versatile to work in many application. (See Fig.1 and 2)

2. Two-step, Sequential Mating

The mating sequence features a 2-step, "first mate-last break" condition that helps to protect the circuit.

3. Mating Guide

A guide rib is provided along with a self-alignment range of ± 1 mm to allow for easy mating operations.

4. SMT Coplanarity

The coplanarity of SMT soldered area has a high accuracy of 0.1mm.

5. Miniaturization

The FX5 uses about 30% less mounting area on the board compared with a 1.27mm pitch connector.

Connecting Height: High profile

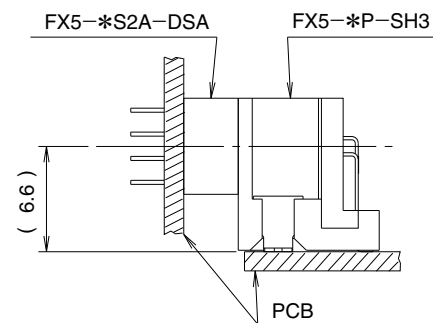

Fig.2

Product Specifications

Ratings	Current rating 0.5A	Operating Temperature Range -55°C to +85°C (Note 1)	Storage Temperature Range -10°C to +60°C (Note 2)
	Voltage rating 100V AC	Operating Humidity Range 40% to 80%	Storage Humidity Range 40% to 70%

Items	Specifications	Conditions
1. Insulation Resistance	100M ohms min.	250V DC
2. Withstanding voltage	No flashover or insulation breakdown.	300V AC/1 minute
3. Contact Resistance	50m ohms max.	100mA
4. Vibration Resistance	No electrical discontinuity of 1μs or more	Frequency: 10 to 55 Hz, single amplitude of 0.75 mm, 2 hours in each of the 3 directions.
5. Moisture Resistance	Contact resistance: 60m ohms max. Insulation resistance: 100M ohms min.	96 hours at temperature of 40°C and humidity of 90% to 95%
6. Temperature Cycle	Contact resistance: 60m ohms max. Insulation resistance: 100M ohms min.	(-55°C: 30 minutes, 15 to 35°C: 2 to 3 minutes 85°C: 30 minutes, 15 to 35°C: 2 to 3minutes) 5 cycles
7. Mating Cycles	Contact resistance: 60m ohms max.	500 cycles
8. Resistance to Soldering heat	No deformation of components affecting performance.	SMT Reflow: At the recommended temperature profile Manual soldering: 360°C for 5 seconds
		DIP Solder Bath: 260°C for 10 seconds Manual soldering: 360°C for 5 seconds

Note 1: Includes temperature rise caused by current flow.

Note 2: The term "storage" refers to products stored for a long time prior to use. Operating temperature and humidity range includes a non-conducting state of installed connectors in storage, shipment, or during transportation.

Material

Part	Material	Finish	Remarks
Insulator	Polyamide	Beige	UL94V-0
Header Contact	Brass	Contact area : Gold plated	———
Receptacle Contact	Phosphor bronze	Lead area : Tin plated	———

Note : The black dots on the insulator will not affect performance

Product Number Structure

Header

FX5 - ***** **P** - **SH** **3**

① ② ③ ④ ⑤

① Series Name : FX5	⑤ Connector Height Blank : 6.5mm 3 : 9.5mm
② Number of Contacts : 20, 40, 52, 56, 68, 80	
③ Connector Type P: Header	
④ Contact type SH : Right angle SMT type	

Note: The 56 contact header is for SH 3 type only.

Receptacle

FX5 - ***** **S** **2** **A** - **DSA** **L**

① ② ③ ④ ⑤ ⑥ ⑦

① Series Name : FX5	⑥ Contact type DSA : Straight through hole type
② Number of Contacts : 20, 40, 52, 56, 68, 80	
③ Connector Type S: Receptacle	⑦ Board prefixed pin Blank : Without board prefixed pin L : With board Prefixed pin
④ Contact Sequence 2 : 2 Stages Sequence	
⑤ Serial No. : A	

Header

Low profile



High profile

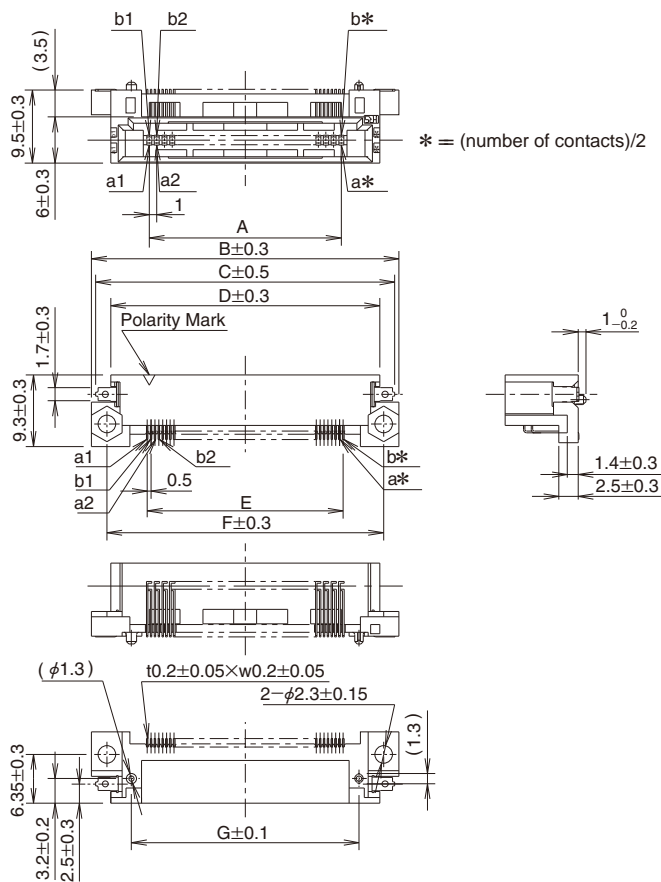
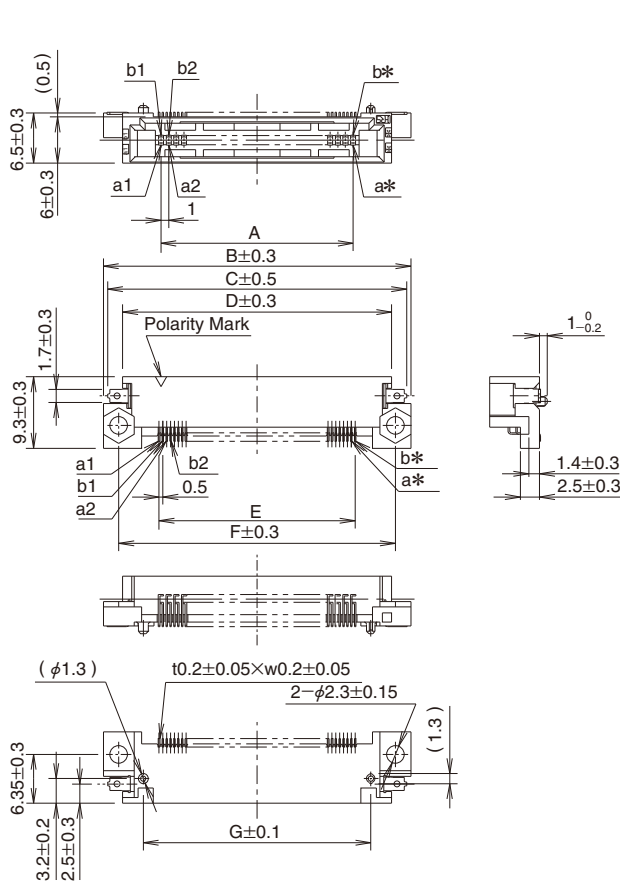

Unit: mm

Part No.	HRS No.	No. of contacts	A	B	C	D	E	F	G	RoHS
FX5-20P-SH(71)	575-0001-7 71	20	9	24	22.9	19	9.5	20	13.6	Yes
FX5-20P-SH3(71)	575-0041-1 71									
FX5-40P-SH(71)	575-0005-8 71	40	19	34	32.9	29	19.5	30	23.6	
FX5-40P-SH3(71)	575-0045-2 71									
FX5-52P-SH(71)	575-0006-0 71	52	25	40	38.9	35	25.5	36	29.6	
FX5-52P-SH3(71)	575-0046-5 71									
FX5-56P-SH3(71)	575-1001-2 71	56	27	42	40.9	37	27.5	38	31.6	
FX5-68P-SH(71)	575-0008-6 71	68	33	48	46.9	43	33.5	44	37.6	
FX5-68P-SH3(71)	575-0048-0 71									
FX5-80P-SH(71)	575-0009-9 71	80	39	54	52.9	49	39.5	50	43.6	
FX5-80P-SH3(71)	575-0049-3 71									

Receptacle

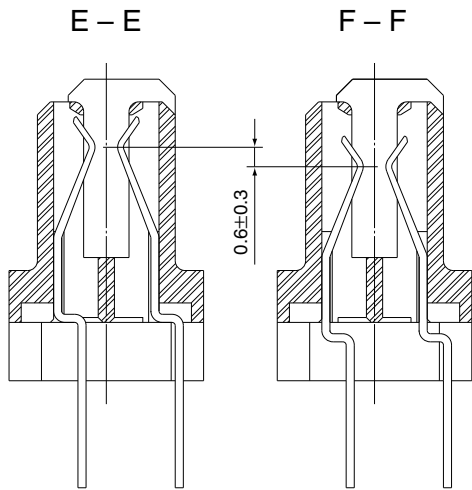
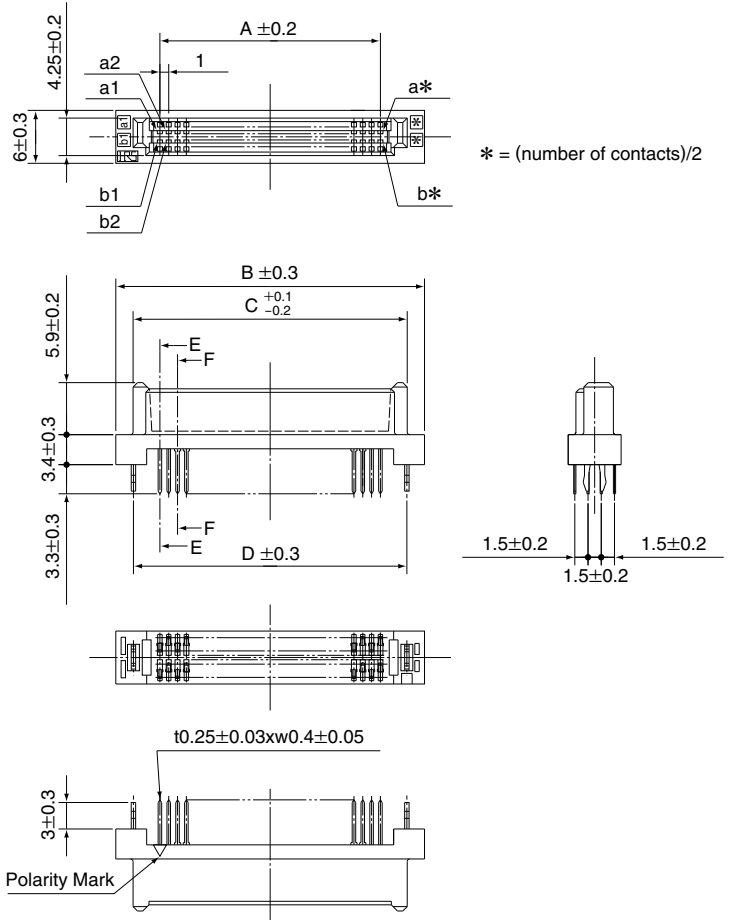
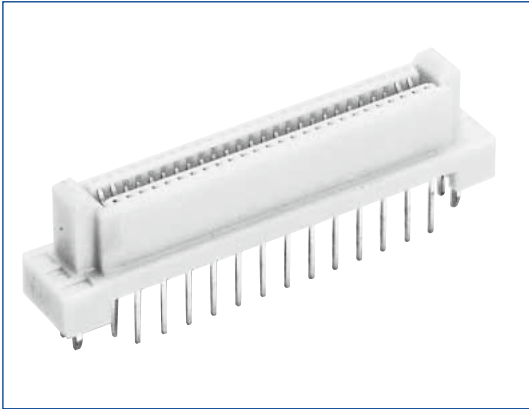

Unit: mm

Part No.	HRS No.	No. of contacts	A	B	C	D	Order of Contact Sequence(Contact No.)		RoHS
							1	2	
FX5-20S2A-DSA(71)	575-0101-1 71	20	9	19	15.08	—	a1,a2,a9,a10	a3 to a8	Yes
FX5-20S2A-DSAL(71)	575-0121-9 71					15	b1,b2,b9,b10	b3 to b8	
FX5-40S2A-DSA(71)	575-0105-2 71	40	19	29	25.08	—	a1,a2,a19,a20	a3 to a18	
FX5-40S2A-DSAL(71)	575-0125-0 71					25	b1,b2,b19,b20	b3 to b18	
FX5-52S2A-DSA(71)	575-0106-5 71	52	25	35	31.08	—	a1,a2,a25,a26	a3 to a24	
FX5-52S2A-DSAL(71)	575-0126-2 71					31	b1,b2,b25,b26	b3 to b24	
FX5-56S2A-DSA(71)	575-0107-8 71	56	27	37	33.08	—	a1,a2,a27,a28	a3 to a26	
FX5-56S2A-DSAL(71)	575-0127-5 71					33	b1,b2,b27,b28	b3 to b26	
FX5-68S2A-DSA(71)	575-0108-0 71	68	33	43	39.08	—	a1,a2,a33,a34	a3 to a32	
FX5-68S2A-DSAL(71)	575-0128-8 71					39	b1,b2,b33,b34	b3 to b32	
FX5-80S2A-DSA(71)	575-0109-3 71	80	39	49	45.08	—	a1,a2,a39,a40	a3 to a38	
FX5-80S2A-DSAL(71)	575-0129-0 71					45	b1,b2,b39,b40	b3 to b38	

PCB mounting pattern

Header

FX5-*-SH, FX5-*-SH3

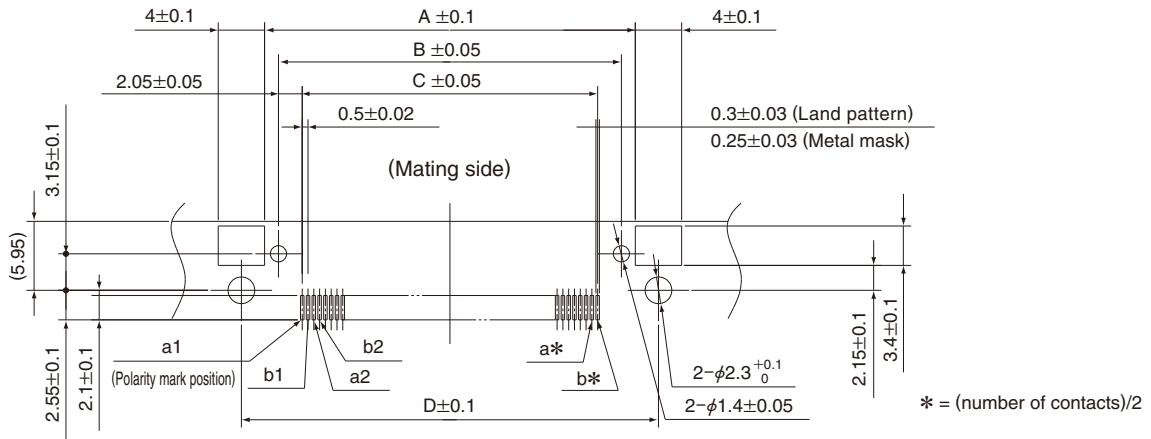

Receptacle

FX5-*-S2A-DSA

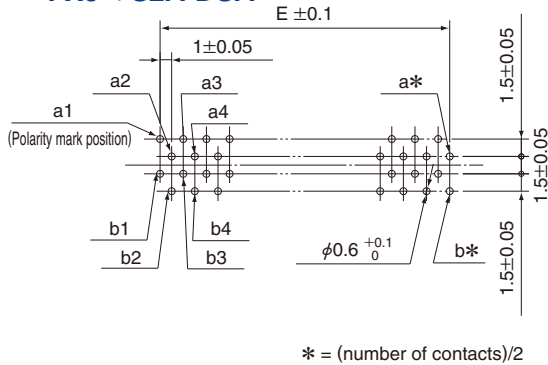

FX5-*-S2A-DSAL

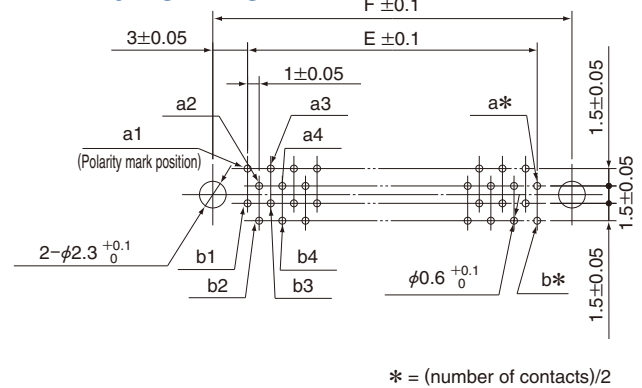

Unit: mm

No. of contacts	A	B	C	D	E	F
20	16	13.6	9.5	20	9	15
40	26	23.6	19.5	30	19	25
52	32	29.6	25.5	36	25	31
56	34	31.6	27.5	38	27	33
68	40	37.6	33.5	44	33	39
80	46	43.6	39.5	50	39	45

Note: If the connector uses a mounting area over the recommended size, it could cause defects in mounting and soldering. For best results, mount the connector using the recommended PCB mounting pattern.

Recommended Temperature Profile

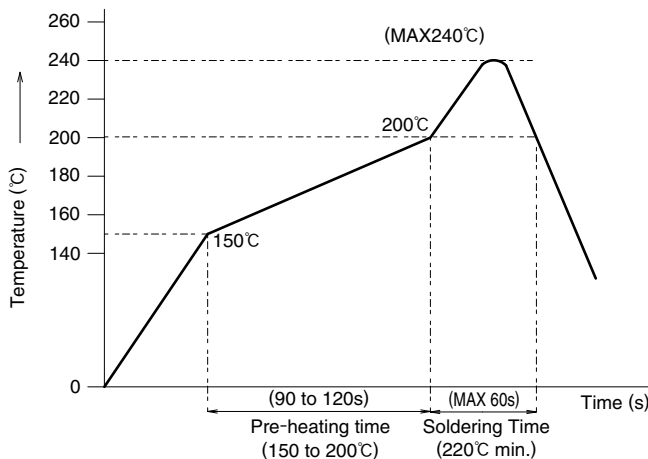

HRS test conditions

Test board Glass epoxy 110mm×40mm×1.6mm thick

Solder method : Reflow

Solder composition : Paste, 96.5%Sn/3%Ag/0.5%Cu

Metal mask : 0.15mm thick

Reflow cycles : 1 cycles

The temperature profile is based on the above conditions.

In individual applications the actual temperature may vary, depending on solder paste type, volume/thickness and board size/thickness. Consult your solder paste and equipment manufacturer for specific recommendations.

◆ Cleaning Conditions

1. Organic Solvent Cleaning

Solvent	Cold Cleaning	
IPA (Isopropyl alcohol)	Yes	Yes

*Methylene chloride is not suitable for this product.

2. Liquid Cleaning

2. When cleaning with liquid detergents (e.g. terpene, alkali saponifiers), consult the manufacturer's specifications and make sure that the cleaner is suitable for use with the metal and resin components of this connector. Also, do not leave the connector outside where it moisture could infiltrate the product.

3. Cautions for Cleaning

3. If any organic solvent or other liquid cleaner or flux remains in the connector, it can cause electrical performance degradation. Please make sure that the connector is completely free of any cleaner or flux before use.

◆ Connector Precautions

1. Tolerance Clearance on Mating Side

The effective clearance of this product is 1.6mm. Please make sure that your design accounts for 1mm mating clearance between the header and receptacle.

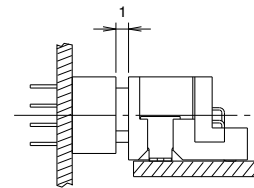

2. Header Connector Height

Because the SMT height specification for the header does not account for the thickness of the solder paste, please remember to account for the extra height in the total stacking height.

Mating Height: Low profile

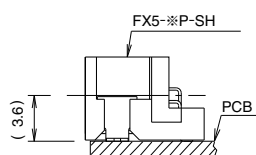

Mating Height: High profile

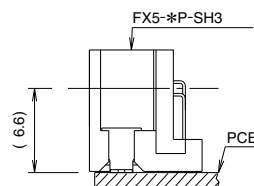

3. Screw Fastening Torque (SMT Type)

When the screw is fastened, please use the M2 screw. The recommended fastening torque is 0.15(N.m) max.

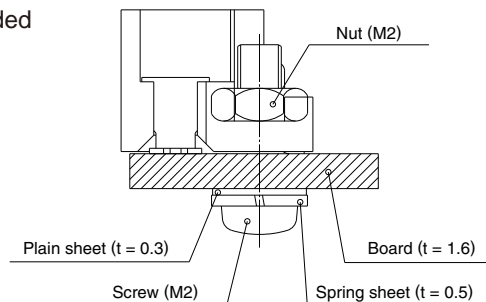

4. Prefixed Process to Board (Through hole Type)

If the prefixed process is required for board mounting, please use the prefixed pin type. (Applicable Thickness $t = 1.6 \pm 0.1$)

Note:

When the connector is mounted on the board, the dip post is guided into the through-hole first. To prevent dip post damage, make sure that the connector is parallel to the board during this process.

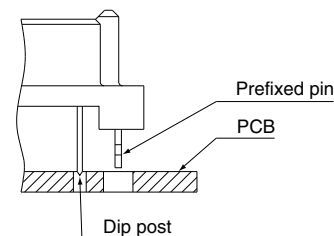

5. Plug and Play

Please consult your Hirose representative if you will be mating/unmating the connector while the circuit is energized.

6. Others

- Excessive force during mating/unmating will damage the connector.
- Avoid using the mated connectors as a means of holding the PCB together.
The PCBs need to be secured together with screws, spacers or other means which do not rely on the connectors as the primary support mechanism.
- The resin color of the product may vary slightly with different production lots.
This does not effect the performance.

USA:

HIROSE ELECTRIC (U.S.A.), INC. HEADQUARTERS
 2688 Westhills Court, Simi Valley, CA 93065-6235
 Phone : +1-805-522-7958
 Fax : +1-805-522-3217
<http://www.hirose.com/us/>

USA:

HIROSE ELECTRIC (U.S.A.), INC. SAN JOSE OFFICE
 3255 Scott Boulevard, Building 7, Suite 101
 Santa Clara, CA 95054
 Phone : +1-408-253-9640
 Fax : +1-408-253-9641
<http://www.hirose.com/us/>

USA:

HIROSE ELECTRIC (U.S.A.), INC. CHICAGO OFFICE
 580 Waters Edge Lane, Suite 205 Lombard IL
 60148
 Phone : +1-630-282-6701
 Mail : inquiries@hirose.com
<http://www.hirose.com/us/>

USA:

HIROSE ELECTRIC (U.S.A.), INC. DETROIT OFFICE (AUTOMOTIVE)
 17197 N. Laurel Park Drive, Suite 253, Livonia,
 MI 48152
 Phone : +1-734-542-9963
 Fax : +1-734-542-9964
<http://www.hirose.com/us/>

THE NETHERLANDS:

HIROSE ELECTRIC EUROPE B.V.
 Hogehillweg #8 1101 CC Amsterdam Z-0
 Phone : +31-20-6557460
 Fax : +31-20-6557469
<http://www.hirose.com/eu/>

GERMANY:

HIROSE ELECTRIC EUROPE B.V. GERMAN BRANCH
 Herzog-Carl-Strasse 4 D-73760 Ostfildern
 (Scharnhauser Park)
 Phone : +49-711-4560-02-1
 Fax : +49-711-4560-02-299
<http://www.hirose.com/eu/>

GERMANY:

HIROSE ELECTRIC EUROPE B.V. NUERNBERG OFFICE
 Muggenhofer Str. 136 90429 Nuernberg
 Phone : +49-911 32 68 89 63
 Fax : +49-911 32 68 89 69
<http://www.hirose.com/eu/>

GERMANY:

HIROSE ELECTRIC EUROPE B.V. HANOVER OFFICE
 Bayernstr. 3, Haus C 30855 Langenhagen, Germany
 Phone : +49-511 97 82 61 30
 Fax : +49-511 97 82 61 35
<http://www.hirose.com/eu/>

FRANCE:

HIROSE ELECTRIC EUROPE B.V. PARIS OFFICE
 Regus La Garenne Colombes, Place de La Belgique,
 71 Boulevard National La Garenne Colombes, 92250, France
 Phone : +33 (0) 1 7082 3170
 Fax : +33 (1) 7082 3101
<http://www.hirose.com/eu/>

UNITED KINGDOM:

HIROSE ELECTRIC EUROPE BV (UK BRANCH)
 4 Newton Court, Kelvin Drive, Knowlhill,
 Milton Keynes, MK5 8NH
 Phone : +44-1908 202050
 Fax : +44-1908 202058
<http://www.hirose.com/eu/>

CHINA:

HIROSE ELECTRIC (SHANGHAI) CO., LTD.
 1601, Henderson Metropolitan, NO.300, East Nanjing
 Road, Huangpu District, Shanghai, China 200001
 Phone : +86-21-6391-3355
 Fax : +86-21-6391-3335
<http://www.hirose.com/cn/>

CHINA:

HIROSE ELECTRIC (SHANGHAI) CO.,LTD. BEIJING BRANCH
 A1001, Ocean International Center, Building 56# East 4th
 Ring Middle Road, ChaoYang District, Beijing, 100025
 Phone : +86-10-5165-9332
 Fax : +86-10-5908-1381
<http://www.hirose.com/cn/>

CHINA:

HIROSE ELECTRIC TECHNOLOGIES (SHENZHEN) CO., LTD.
 Room 09-13, 19/F, Office Tower Shun Hing Square, Di Wang Commercial Centre,
 5002 Shen Nan Dong Road, Shenzhen City, Guangdong Province, 518008
 Phone : +86-755-8207-0851
 Fax : +86-755-8207-0873
<http://www.hirose.com/cn/>

HONG KONG:

HIROSE ELECTRIC HONGKONG TRADING CO., LTD.
 Room 1001, West Wing, Tsim Sha Tsui Centre, 66
 Mody Road, Tsim Sha Tsui East, Kowloon, Hong Kong
 Phone : +852-2803-5338
 Fax : +852-2591-6560
<http://www.hirose.com/hk/>

TAIWAN:

HIROSE ELECTRIC TAIWAN CO., LTD.
 103 8F, No.87, Zhengzhou Rd., Taipei
 Phone : +886-2-2555-7377
 Fax : +886-2-2555-7350
<http://www.hirose.com/tw/>

KOREA:

HIROSE KOREA CO., LTD.
 250, Huimanggongwon-ro, Siheung-si,
 Gyeonggi-do, Korea, 429-849
 Phone : +82-31-496-7000,7124
 Fax : +82-31-496-7100
<http://www.hirose.co.kr/>

SINGAPORE:

HIROSE ELECTRIC SINGAPORE PTE. LTD.
 10 Anson Road #26-16, International Plaza
 079903, Singapore
 Phone : +65-6324-6113
 Fax : +65-6324-6123
<http://www.hirose.com/sg/>

INDIA:

HIROSE ELECTRIC SINGAPORE PTE. LTD. DELHI LIAISON OFFICE
 Office NO.519, Regus-Green Boulevard, Level5, Tower C,
 Sec62, Plot B-9A, Block B, Noida, 201301, Uttar Pradesh, India
 Phone : +91-12-660-8018
 Fax : +91-120-4804949
<http://www.hirose.com/sg/>

INDIA:

HIROSE ELECTRIC SINGAPORE PTE. LTD. BANGALORE LIAISON OFFICE
 Unit No-403, 4th Floor, No-84, Barton Centre, Mahatma
 Gandhi (MG) Road, Bangalore 560 001, Karnataka, India
 Phone : +91-80-4120 1907
 Fax : +91-80-4120 9908
<http://www.hirose.com/sg/>

MALAYSIA:

HIROSE ELECTRIC SINGAPORE PTE. LTD.
 1-10-07, Suntech @ Penang Cybercity (1164),Lintang
 Mayang Pasir 3,11950, Bayan Baru, Penang, Malaysia.
 Phone : +604-619-2564
 Fax : +604-619-2574
<http://www.hirose.com/sg/>

THAILAND:

HIROSE ELECTRIC SINGAPORE PTE. LTD. BANGKOK OFFICE (REPRESENTATIVE OFFICE)
 Unit 4703, 47th FL., 1 Empire Tower, South Sathorn
 Road, Yannawa, Sathorn, Bangkok 10120 Thailand
 Phone : +66-2-686-1255
 Fax : +66-2-686-3433
<http://www.hirose.com/sg/>



HIROSE ELECTRIC CO.,LTD.

2-6-3,Nakagawa Chuoh,Tsuzuki-Ku,Yokohama-Shi 224-8540,JAPAN
 TEL: +81-45-620-3526 Fax: +81-45-591-3726
<http://www.hirose.com>
<http://www.hirose-connectors.com>