



1D14C_S3UP & 1D14C_D3UP Series

1W - Single/Dual Output DC-DC Converter - Fixed Input - Isolated & Unregulated

DC-DC Converter 1 Watt

- ⊕ High efficiency up to 81%
- ⊕ High density, high stability
- ⊕ 3000VDC Isolation
- ⊕ DIP package
- ⊕ Meet EN60950, UL60950
- ⊕ Short circuit protection (SCP)
- ⊕ Temperature range: -40°C ~ +105°C
- ⊕ No external component required
- ⊕ Industry standard pinout
- ⊕ RoHS compliance

The 1D14C_S3UP & 1D14C_D3UP Series are specially designed for applications where an isolated voltage is required in a distributed power supply system.

These products apply to:

- 1) Where the voltage of the input power supply is fixed (voltage variation $\leq \pm 10\%$)
- 2) Where isolation is necessary between input and output (isolation voltage $\leq 3000\text{VDC}$)
- 3) Where the output voltage regulation and the ripple & noise of the output voltage is not strictly required;

Typical application: digit circuit condition; normal low-frequency artificial circuit condition; relay drive circuit and data switching circuit condition, etc..



Common specifications	
Short circuit protection*:	Continuous, self-recovery 1 second for models 1D14C_2405S3U/ 1D14C_24xxD3U/1D14C_0303S3U
Temperature rise at full load:	25°C TYP
Cooling:	Free air convection
Operation temperature range:	-40°C – +105°C
Storage temperature range:	-55°C – +125°C
Casing temperature rise:	25°C TYP, Ta = 25°C, nominal input, full load output
Lead temperature	300°C MAX, 1.5mm from case for 10 sec
Storage humidity range:	< 95%
Case material:	Plastic [U94-VO]
MTBF (MIL-HDBK-217F@25°C):	>3,500,000 hours
Weight:	2.4g

* Supply voltage must be discontinued at the end of short circuit duration for: 1D14C_2405S3U/1D14C_24xxD3U/1D14C_0303S3U series.

Input specifications					
Item	Test condition	Min	Typ	Max	Units
Input current	• 3.3V input		420/30	-/70	mA
	• 5V input		256/20	-/60	mA
	• 12V input		106/15	-/50	mA
	• 15V input		84/10	-/35	mA
	• 24V input		54/7	-/30	mA
Reflected ripple current					
Surge voltage (1 sec. max)	• 3.3V input	-0.7		5	VDC
	• 5V input	-0.7		9	VDC
	• 12V input	-0.7		18	VDC
	• 15V input	-0.7		21	VDC
	• 24V input	-0.7		30	VDC
Input filter	Filter capacitor				
Hot plug	unavailable				

Isolation specifications					
Item	Test condition	Min	Typ	Max	Units
Isolation voltage	Tested for 1 minute and 1mA max	3000			VDC
Isolation resistance	Test at 500VDC	1000			MΩ
Isolation capacitance	Input-output, 100KHz/0.1V		20		pF

Output specifications						
Item	Test condition	Min	Typ	Max	Units	
Output voltage accuracy	See tolerance envelope graph @Typical characteristics					
Line regulation	For Vin change of 1%					
	• 3.3VDC output		±1.5			%
	• Other output		±1.2			%
Load regulation	10% to 100% load					
	• 3.3V output		18			%
	• 5V output		12			%
	• 12V output		8			%
	• 15V output		7			%
Temperature drift	100% full load			±0.03		%/°C
Ripple & Noise*	20MHz Bandwidth		60	150		mVp-p

EMC specifications			
EMI / CE		CISPR22/EN55022, CLASS B (see EMC solution-recommended circuit)	
EMI / RE		CISPR22/EN55022, CLASS B (see EMC solution-recommended circuit)	
EMS / ESD	Single Dual	IEC/EN 61000-4-2 IEC/EN 61000-4-2	Contact ±8KV / perf. Criteria B Contact ±6KV / perf. Criteria B

Example:

1D14C_0505D3UP

1 = 1Watt; D14 = DIP14; C = Pinning; 5Vin; 5Vout; D =Dual Output;
3 = 3kVDC; U = Unregulated Output; P = Short circuit protection

Note:

1. If the product is not operated within the required load range, the product performance cannot be guaranteed to comply with all parameters in the datasheet;
2. The maximum capacitive load offered were tested at nominal input voltage and full load;
3. Unless otherwise specified, parameters in this datasheet were measured under the conditions of Ta = 25°C, humidity <75% with nominal input voltage and rated output load;
4. All index testing methods in this datasheet are based on our Company's corporate standards;
5. The performance parameters of the product models listed in this manual are as above, but some parameters of non-standard model products may exceed the requirements mentioned above. Please contact our technicians directly for specific information;
6. We can provide product customization service;
7. Specifications are subject to change without prior notice.

1D14C_S3UP & 1D14C_D3UP Series

1W - Single/Dual Output DC-DC Converter - Fixed Input - Isolated & Unregulated

Product Selection Guide

Part Number	Input Voltage [VDC]	Output Voltage [VDC]	Output Current [mA, max./min.]	Efficiency [%, typ]	Capacitive load [μ F, max.]
1D14C_0303S3U	3.3	3.3	303/31	72	220
1D14C_0505S3UP	5	5	200/20	80	220
1D14C_0512S3UP	5	12	83/9	80	220
1D14C_0515S3UP	5	15	67/7	81	220
1D14C_1205S3UP	12	5	200/20	80	220
1D14C_1212S3UP	12	12	83/9	80	220
1D14C_1215S3UP	12	15	67/7	81	220
1D14C_1515S3UP	15	15	67/7	80	220
1D14C_2405S3U	24	5	200/20	79	220
1D14C_0505D3UP	5	± 5	$\pm 100/\pm 10$	79	100
1D14C_0512D3UP	12	± 12	$\pm 42/\pm 5$	80	100
1D14C_0515D3UP	15	± 15	$\pm 34/\pm 3$	81	100
1D14C_2412D3U	24	± 12	$\pm 42/\pm 5$	81	100
1D14C_2415D3U	24	± 15	$\pm 34/\pm 3$	80	100

Typical characteristics

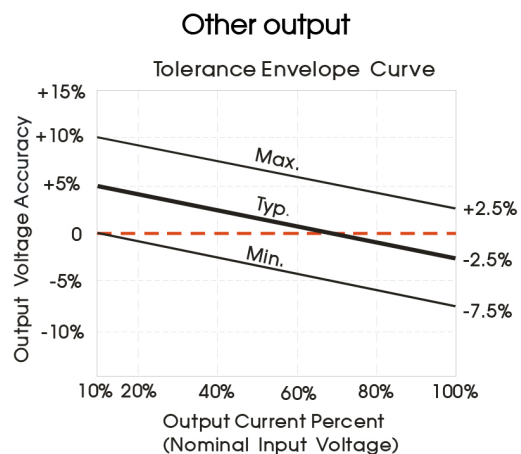
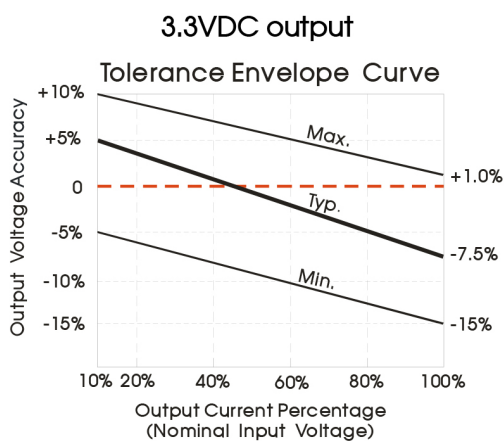
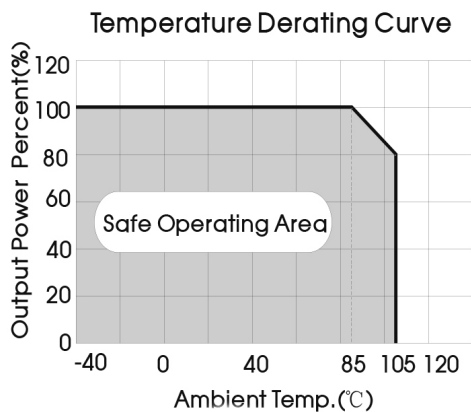

1D14C_S3UP & 1D14C_D3UP Series

1W - Single/Dual Output DC-DC Converter - Fixed Input - Isolated & Unregulated

Typical application circuit

If it is required to further reduce input and output ripple, a filter capacitor may be connected to the input and output terminals, see Fig.1. Moreover, choosing a suitable filter capacitor is very important, start-up problems may be caused if the capacitance is too large. Under the condition of safe and reliable operation, the recommended capacitive load values are shown in Table 1.

Vin (VDC)	Cin (μF)	Single Vout (VDC)	Cout (μF)	Dual Vout (VDC)	Cout (μF)
3.3/5	4.7	3.3/5	10	±5	4.7
12	2.2	12	2.2	±12	1
15	2.2	15	1.	±15	0.47
24	1	-	-	-	-

It is not recommended to connect any external capacitor when output power is less than 0.5W.

Dual Output



Single Output



Fig. 1

EMC solution-recommended circuit

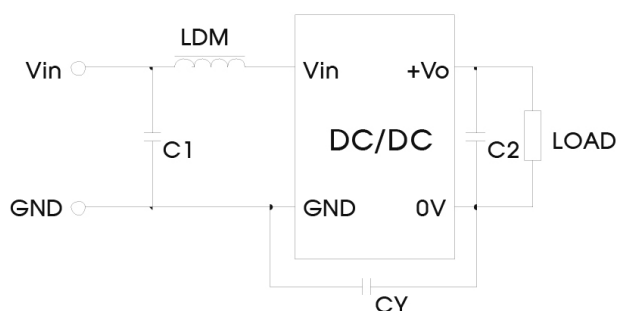

Input voltage (VDC)		3.3/5/12	15/24
EMI	C1	Refer to the Cout in Fig.1	
	C2	1000pF	2KV
	LDM	6.8μH	
	CY	-	1nF/3KV

- 15/24V input series, is subject to CY (CY : 1nF/3KV).
- It is not needed to add the component in the peripheral circuit when parameter with the symbol of „-“.

Output load requirements:

In order to ensure the converter can work reliably with high efficiency, the minimum load should not less than 10% rated load when it is used. If the needed power is indeed small, please parallel a resistor on the output side (the sum of the efficient power and resistor consumption power is not less than 10%).

1D14C_S3UP & 1D14C_D3UP Series

1W - Single/Dual Output DC-DC Converter - Fixed Input - Isolated & Unregulated

Efficiency

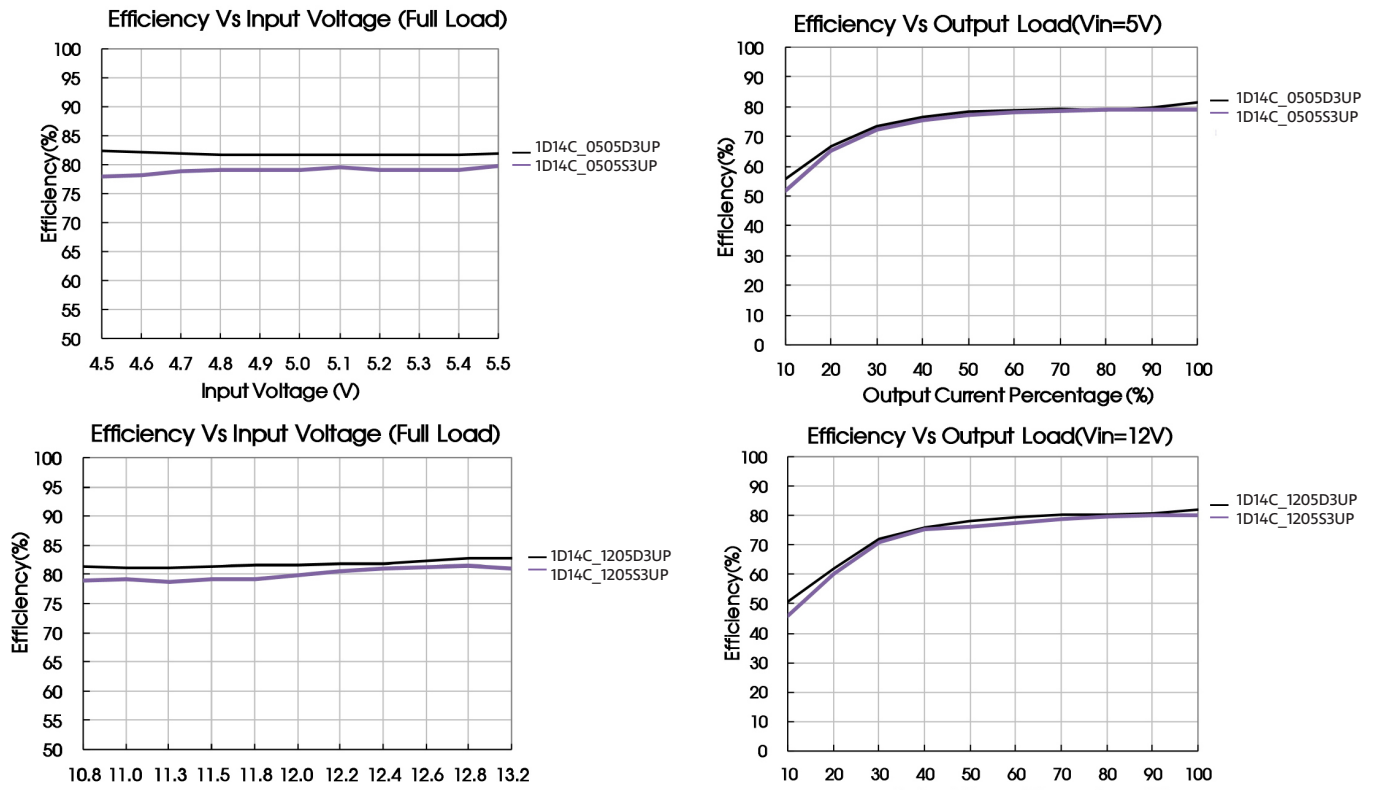

Mechanical dimensions

