

ELR H5-I-PT-24DC/500AC-2-L - Hybrid motor starter



1199926

<https://www.phoenixcontact.com/us/products/1199926>

Please be informed that the data shown in this PDF document is generated from our online catalog. Please find the complete data in the user documentation. Our general terms of use for downloads are valid.



Hybrid motor starter, for reversing 3~ AC motors up to 550 V AC/2.4 A, 24 V DC input, class 10 tripping characteristic, overload function, without symmetry monitoring, and without phase failure and underload detection. 1-phase motors can be switched.

Commercial data

Item number	1199926
Packing unit	1 pc
Minimum order quantity	1 pc
Sales key	C470
Product key	CK7422
GTIN	4063151262891
Weight per piece (including packing)	284 g
Weight per piece (excluding packing)	217.7 g
Customs tariff number	85371098
Country of origin	DE

ELR H5-I-PT-24DC/500AC-2-L - Hybrid motor starter



1199926

<https://www.phoenixcontact.com/us/products/1199926>

Technical data

Product properties

Product type	Hybrid motor starters
Product family	CONTACTRON
Operating mode	100% operating factor

Electrical properties

Number of phases	3
Motor starter type	Reversing starter
Maximum power dissipation for nominal condition	2.2 W
Switching frequency	≤ 2 Hz (Load-dependent)
Maximum power dissipation	3.3 W
Minimum power dissipation	1.1 W
Coordination type	1

Supply

Rated control circuit supply voltage U_S	24 V DC
Control supply voltage range	19.2 V DC ... 30 V DC
Rated control supply current I_S	40 mA
Protective circuit	Surge protection
	Reverse polarity protection

Insulation characteristics

Rated insulation voltage	500 V
Rated surge voltage	6 kV
Overvoltage category	III
Degree of pollution	2
Insulation characteristics between the control input and control supply voltage, and auxiliary circuit to the main circuit	Safe isolation (IEC 60947-1) at operating voltage ≤ 300 V AC
	Safe isolation (EN 50178) at operating voltage ≤ 300 V AC
	Basic insulation (IEC 60947-1) at operating voltage 300 V AC ... 500 V AC
	Safe isolation (EN 50178) at operating voltage 300 ... 500 V AC
Isolation characteristics between the control input and control supply voltage to auxiliary circuit	Safe isolation (IEC 60947-1) in the auxiliary circuit ≤ 300 V AC
	Safe isolation (EN 50178) in the auxiliary circuit ≤ 300 V AC

Input data

Control

Input name	Control input right/left
Rated actuating voltage U_C	24 V DC
Triggering voltage range	19.2 V DC ... 30 V DC
Rated actuating current I_C	5 mA (Input type 1)
Switching threshold	9.6 V ("0" signal)
	19.2 V ("1" signal)

ELR H5-I-PT-24DC/500AC-2-L - Hybrid motor starter



1199926

<https://www.phoenixcontact.com/us/products/1199926>

Typical turn-off time	< 30 ms
Protective circuit	Reverse polarity protection

Output data

AC output

Rated operating voltage U_e	500 V AC
Operating voltage range	42 V AC ... 550 V AC
Rated operating current I_e	2.4 A (AC-51) 2.4 A (AC-53a)
Mains frequency	50/60 Hz
Load current range	180 mA ... 2.4 A (see to derating)
Trigger characteristic in acc. with IEC 60947-4-2	Class 10
Cooling time	20 min. (for auto reset)
Leakage current	0 mA
Protective circuit	Surge protection

Acknowledge output

Note	Confirmation: floating change-over contact, signal contact
Switching capacity in accordance with IEC 60947-5-1	3 A (230 V, AC15) 2 A (24 V, DC13)

Connection data

Control circuits

Connection method	Push-in connection
Stripping length	10 mm
Conductor cross section rigid	0.2 mm ² ... 2.5 mm ²
Conductor cross section flexible	0.2 mm ² ... 2.5 mm ²
Conductor cross section AWG	24 ... 14

Load circuit

Connection method	Push-in connection
Stripping length	10 mm
Conductor cross section rigid	0.2 mm ² ... 2.5 mm ²
Conductor cross section flexible	0.2 mm ² ... 2.5 mm ²
Conductor cross section AWG	24 ... 14

Signaling

Status display	Yellow LED
Operating voltage display	Green LED
Error indication	Red LED

Dimensions

Width	22.5 mm
Height	107.5 mm

ELR H5-I-PT-24DC/500AC-2-L - Hybrid motor starter



1199926

<https://www.phoenixcontact.com/us/products/1199926>

Depth	114 mm
-------	--------

Material specifications

Flammability rating according to UL 94	V0 (Housing)
--	--------------

Environmental and real-life conditions

Ambient conditions

Degree of protection	IP20
Ambient temperature (operation)	-25 °C ... 70 °C (observe derating)
Ambient temperature (storage/transport)	-40 °C ... 80 °C
Altitude	≤ 2000 m

Approvals

UKCA

Certificate	UKCA-compliant
-------------	----------------

UL approval

Certificate	NLDX.E228652
-------------	--------------

UL data

SCCR	100 kA (500 V AC (fuse: 30 A class CC/30 A class J (high fault)))
	5 kA (500 V AC (fuse: 20 A RK5 (standard fault)))
FLA	2.4 A (500 V AC)
Group installation	20 A (class RK5, SCCR 5kA, #24 - 14 AWG max. solid and stranded)
	30 A (class CC or J, SCCR 100kA, #24 - 14 AWG max, solid and stranded)
Category code	NLDX / NRNT

Standards and regulations

Standards/regulations

Standards/regulations	IEC 60947-1
	IEC 60947-4-2
	IEC 61508
	ISO 13849

Mounting

Mounting type	DIN rail mounting
Assembly instructions	alignable, for spacing see derating
Mounting position	vertical (horizontal DIN rail, motor output below)

Drawings

Circuit diagram

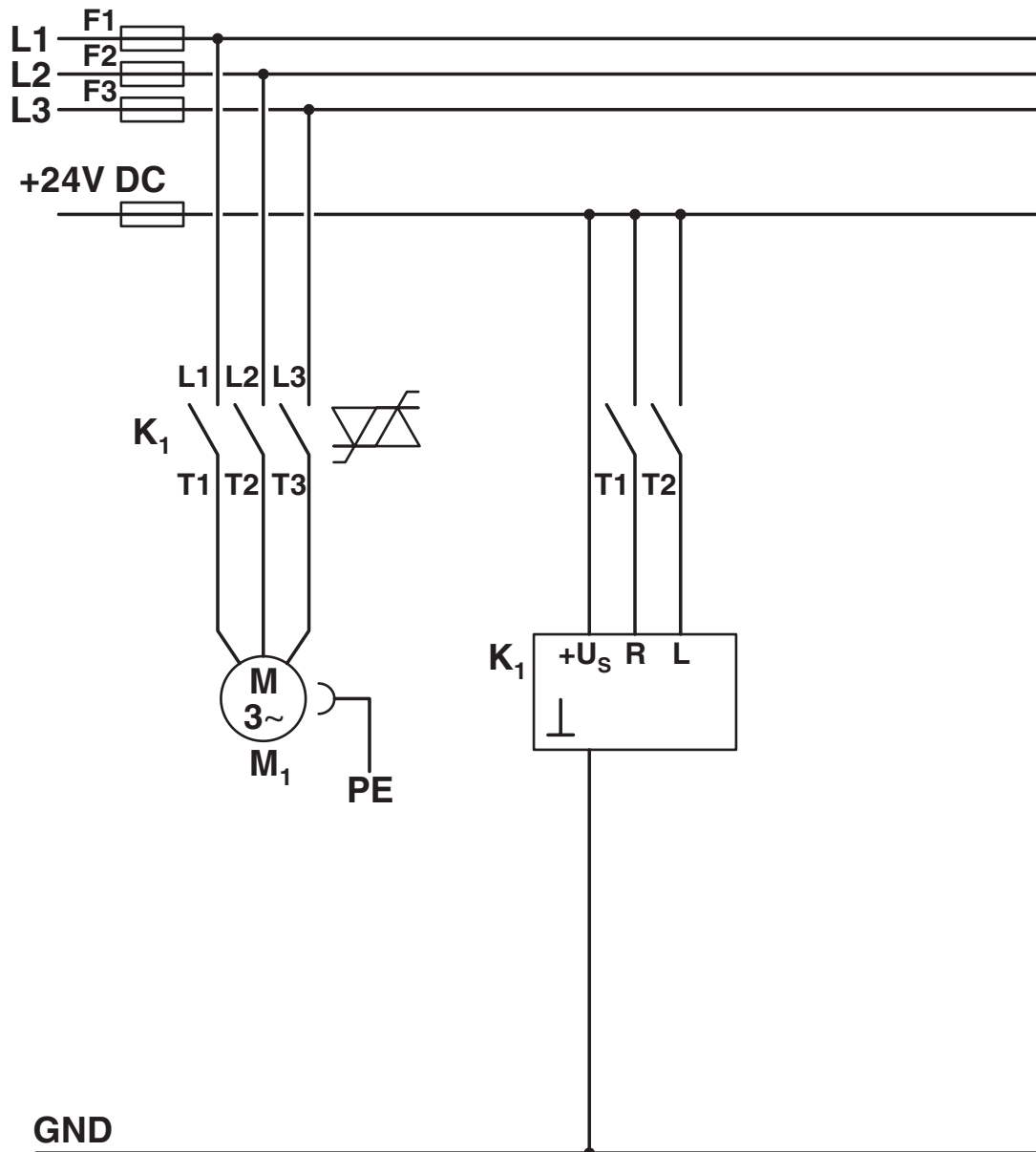

ELR H5-I-PT-24DC/500AC-2-L - Hybrid motor starter



1199926

<https://www.phoenixcontact.com/us/products/1199926>

Circuit diagram

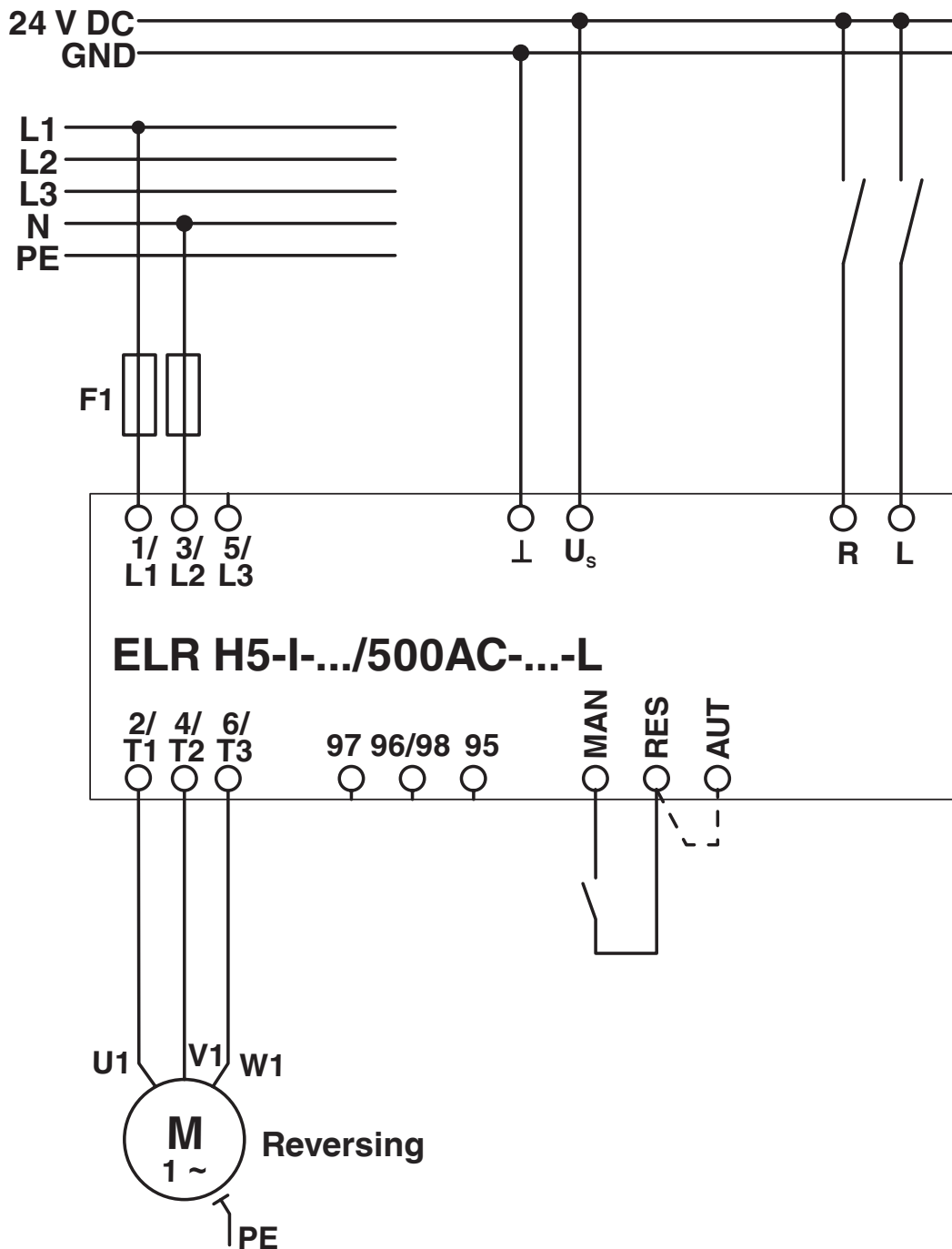

Circuit diagram

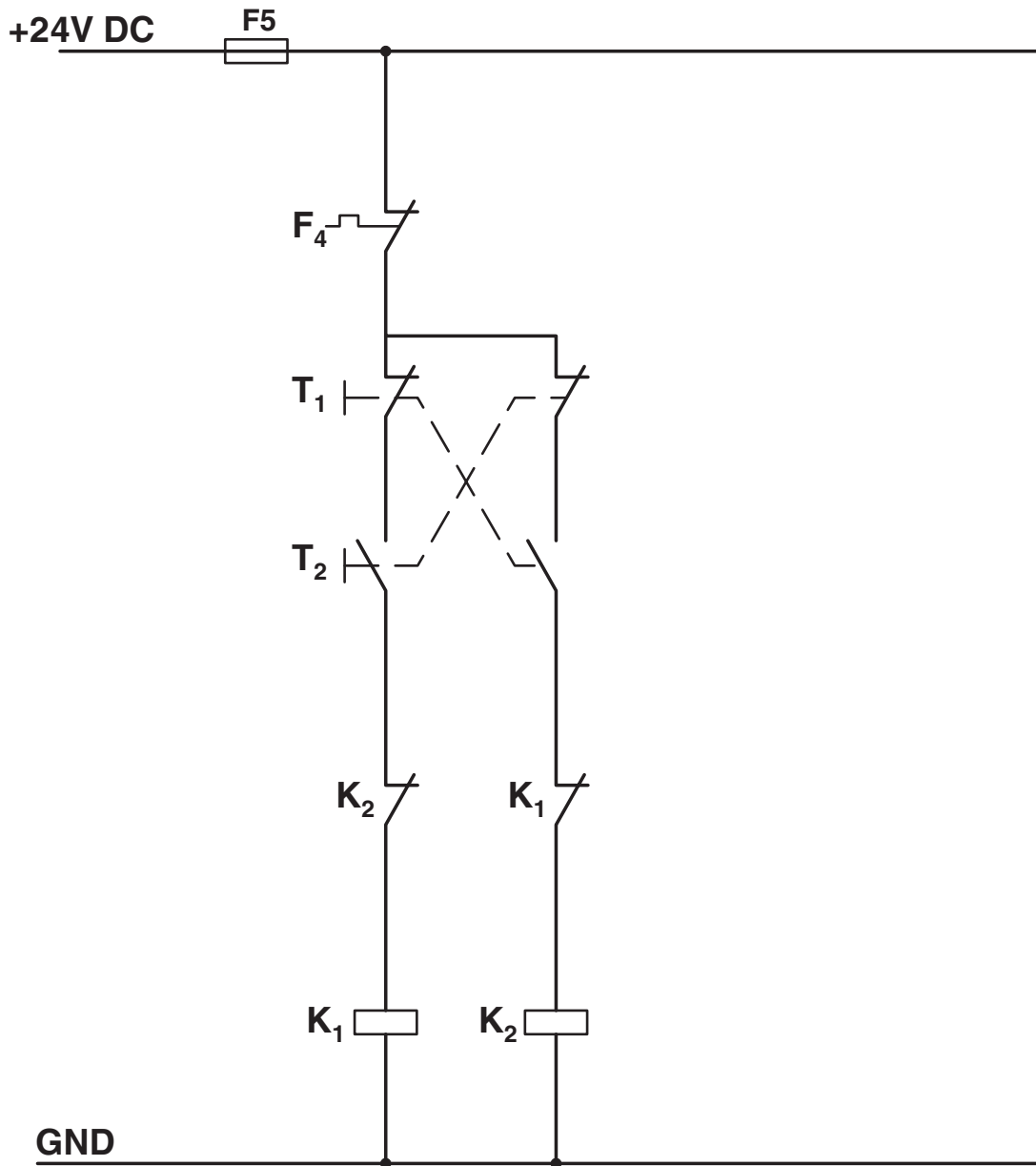

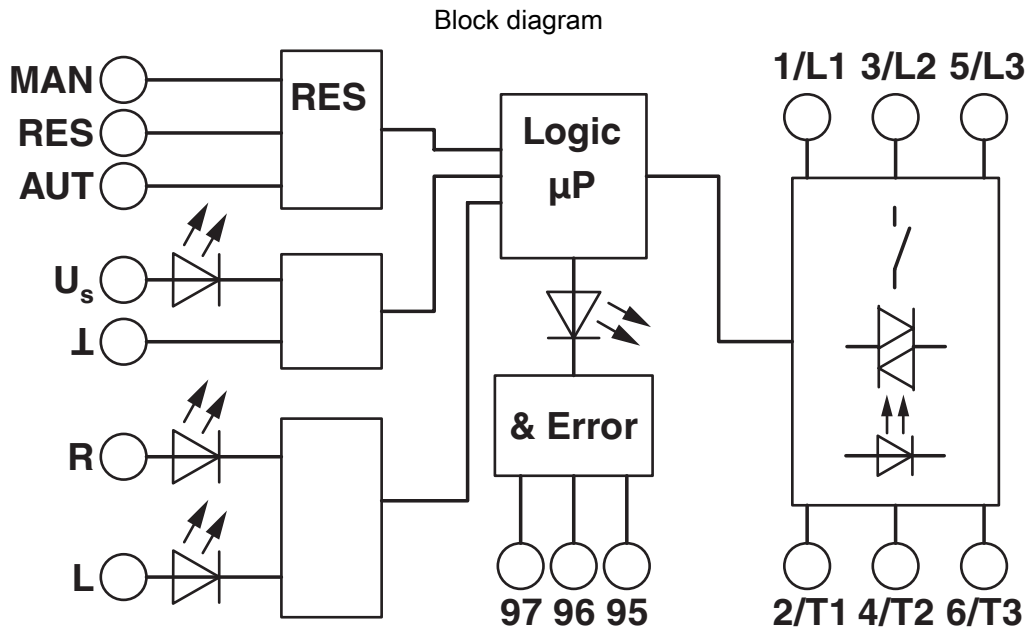

1199926

<https://www.phoenixcontact.com/us/products/1199926>

Circuit diagram

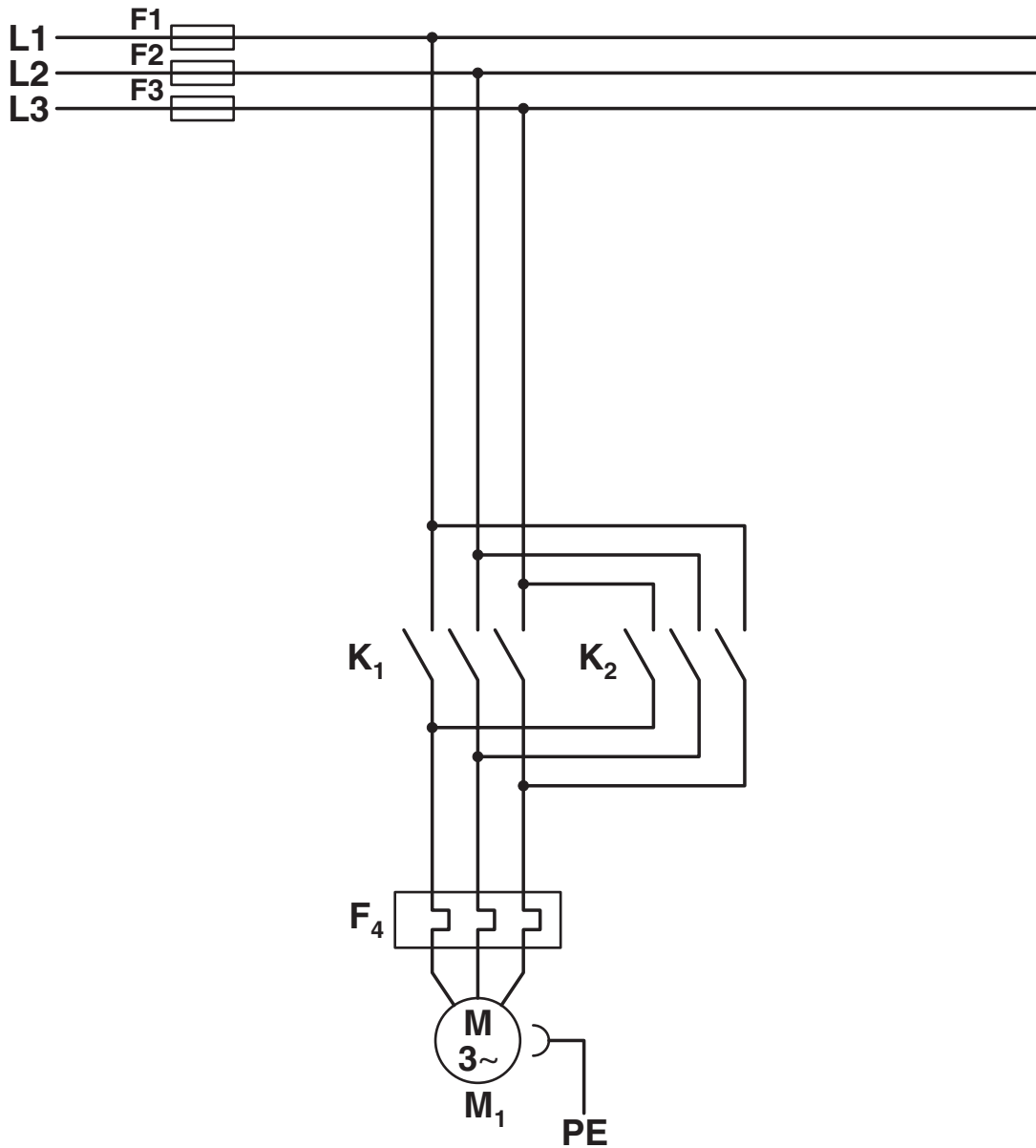

1199926

<https://www.phoenixcontact.com/us/products/1199926>

Approvals

To download certificates, visit the product detail page: <https://www.phoenixcontact.com/us/products/1199926>



EAC

Approval ID: RU*C-DE.*08.B.00520*



UL Listed

Approval ID: FILE E 323771



CCC

Approval ID: 2016010304871315



cUL Listed

Approval ID: FILE E 323771



cUL Listed

Approval ID: FILE E 228652



UL Listed

Approval ID: FILE E 228652

ELR H5-I-PT-24DC/500AC-2-L - Hybrid motor starter



1199926

<https://www.phoenixcontact.com/us/products/1199926>

Classifications

ECLASS

ECLASS-11.0	27370905
ECLASS-13.0	27370905
ECLASS-12.0	27370905

ETIM

ETIM 9.0	EC001037
----------	----------

UNSPSC

UNSPSC 21.0	25173900
-------------	----------

ELR H5-I-PT-24DC/500AC-2-L - Hybrid motor starter



1199926

<https://www.phoenixcontact.com/us/products/1199926>

Environmental product compliance

REACH SVHC

Lead 7439-92-1

ELR H5-I-PT-24DC/500AC-2-L - Hybrid motor starter



1199926

<https://www.phoenixcontact.com/us/products/1199926>

Accessories

BRIDGE-PT 1 - Bridge

1161777

<https://www.phoenixcontact.com/us/products/1161777>

3-phase loop bridge for 1 CONTACTRON module, with Push-in connection and 22.5 mm housing width, connecting cable: 3 m



BRIDGE-PT 2 - Bridge

2904490

<https://www.phoenixcontact.com/us/products/2904490>

3-phase loop bridge for 2 CONTACTRON modules, with Push-in connection and 22.5 mm housing width, connecting cable: 3 m



ELR H5-I-PT-24DC/500AC-2-L - Hybrid motor starter



1199926

<https://www.phoenixcontact.com/us/products/1199926>

BRIDGE-PT 3 - Bridge

2904491

<https://www.phoenixcontact.com/us/products/2904491>

3-phase loop bridge for 3 CONTACTRON modules, with Push-in connection and 22.5 mm housing width, connecting cable: 3 m



BRIDGE-PT 4 - Bridge

2904492

<https://www.phoenixcontact.com/us/products/2904492>

3-phase loop bridge for 4 CONTACTRON modules, with Push-in connection and 22.5 mm housing width, connecting cable: 3 m



ELR H5-I-PT-24DC/500AC-2-L - Hybrid motor starter



1199926

<https://www.phoenixcontact.com/us/products/1199926>

BRIDGE-PT 5 - Bridge

2904493

<https://www.phoenixcontact.com/us/products/2904493>

3-phase loop bridge for 5 CONTACTRON modules, with Push-in connection and 22.5 mm housing width, connecting cable: 3 m



BRIDGE-PT 6 - Bridge

2904494

<https://www.phoenixcontact.com/us/products/2904494>

3-phase loop bridge for 6 CONTACTRON modules, with Push-in connection and 22.5 mm housing width, connecting cable: 3 m



ELR H5-I-PT-24DC/500AC-2-L - Hybrid motor starter



1199926

<https://www.phoenixcontact.com/us/products/1199926>

BRIDGE-PT 7 - Bridge

2904495

<https://www.phoenixcontact.com/us/products/2904495>

3-phase loop bridge for 7 CONTACTRON modules, with Push-in connection and 22.5 mm housing width, connecting cable: 3 m



BRIDGE-PT 8 - Bridge

2904496

<https://www.phoenixcontact.com/us/products/2904496>

3-phase loop bridge for 8 CONTACTRON modules, with Push-in connection and 22.5 mm housing width, connecting cable: 3 m



ELR H5-I-PT-24DC/500AC-2-L - Hybrid motor starter



1199926

<https://www.phoenixcontact.com/us/products/1199926>

BRIDGE-PT 9 - Bridge

2904497

<https://www.phoenixcontact.com/us/products/2904497>

3-phase loop bridge for 9 CONTACTRON modules, with Push-in connection and 22.5 mm housing width, connecting cable: 3 m



BRIDGE-PT 10 - Bridge

2904498

<https://www.phoenixcontact.com/us/products/2904498>

3-phase loop bridge for 10 CONTACTRON modules, with Push-in connection and 22.5 mm housing width, connecting cable: 3 m



ELR H5-I-PT-24DC/500AC-2-L - Hybrid motor starter



1199926

<https://www.phoenixcontact.com/us/products/1199926>

BRIDGE-PT 1-1M - Bridge

1161778

<https://www.phoenixcontact.com/us/products/1161778>

3-phase loop bridge for 1 CONTACTRON module, with Push-in connection and 22.5 mm housing width, connecting cable: 1 m



BRIDGE-PT-2-1M - Bridge

1049407

<https://www.phoenixcontact.com/us/products/1049407>

3-phase loop bridge for 2 CONTACTRON modules, with Push-in connection and 22.5 mm housing width, connecting cable: 1 m



ELR H5-I-PT-24DC/500AC-2-L - Hybrid motor starter



1199926

<https://www.phoenixcontact.com/us/products/1199926>

BRIDGE-PT-3-1M - Bridge

1049408

<https://www.phoenixcontact.com/us/products/1049408>

3-phase loop bridge for 3 CONTACTRON modules, with Push-in connection and 22.5 mm housing width, connecting cable: 1 m



BRIDGE-PT-4-1M - Bridge

1049409

<https://www.phoenixcontact.com/us/products/1049409>

3-phase loop bridge for 4 CONTACTRON modules, with Push-in connection and 22.5 mm housing width, connecting cable: 1 m



ELR H5-I-PT-24DC/500AC-2-L - Hybrid motor starter



1199926

<https://www.phoenixcontact.com/us/products/1199926>

BRIDGE-PT-5-1M - Bridge

1049413

<https://www.phoenixcontact.com/us/products/1049413>

3-phase loop bridge for 5 CONTACTRON modules, with Push-in connection and 22.5 mm housing width, connecting cable: 1 m



BRIDGE-PT-2-2M/0,3M - Bridge

1107649

<https://www.phoenixcontact.com/us/products/1107649>

3-phase loop bridge for 2 CONTACTRON modules, with Push-in connection and 22.5 mm housing width, cable length between the modules: 0.3 m, connecting cable: 2 m



ELR H5-I-PT-24DC/500AC-2-L - Hybrid motor starter



1199926

<https://www.phoenixcontact.com/us/products/1199926>

BRIDGE-PT-3-2M/0,3M - Bridge

1107650

<https://www.phoenixcontact.com/us/products/1107650>



3-phase loop bridge for 3 CONTACTRON modules, with Push-in connection and 22.5 mm housing width, cable length between the modules: 0.3 m, connecting cable: 2 m

BRIDGE-PT-4-2M/0,3M - Bridge

1107644

<https://www.phoenixcontact.com/us/products/1107644>



3-phase loop bridge for 4 CONTACTRON modules, with Push-in connection and 22.5 mm housing width, cable length between the modules: 0.3 m, connecting cable: 2 m

ELR H5-I-PT-24DC/500AC-2-L - Hybrid motor starter



1199926

<https://www.phoenixcontact.com/us/products/1199926>

US-EMLP (15X5) - Plastic label

0828790

<https://www.phoenixcontact.com/us/products/0828790>



Plastic label, Card, white, unlabeled, can be labeled with: BLUEMARK ID COLOR, BLUEMARK ID, THERMOMARK PRIME, THERMOMARK CARD 2.0, THERMOMARK CARD, mounting type: adhesive, lettering field size: 15 x 5 mm, Number of individual labels: 189

UC-EMLP (15X5) - Plastic label

0819301

<https://www.phoenixcontact.com/us/products/0819301>



Plastic label, Sheet, white, unlabeled, can be labeled with: BLUEMARK ID COLOR, BLUEMARK ID, BLUEMARK CLED, PLOTMARK, CMS-P1-PLOTTER, mounting type: adhesive, lettering field size: 15 x 5 mm, Number of individual labels: 10

ELR H5-I-PT-24DC/500AC-2-L - Hybrid motor starter



1199926

<https://www.phoenixcontact.com/us/products/1199926>

EM-CPS-225 - Power distribution board

1002634

<https://www.phoenixcontact.com/us/products/1002634>

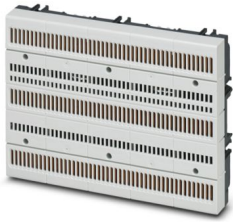

Modular power distribution board with CrossLink[®] interface, 125 A, 3-pos., touch-proof and protection against polarity reversal, width: 225 mm

EM-CPS-405 - Power distribution board

1002635

<https://www.phoenixcontact.com/us/products/1002635>



Modular power distribution board with CrossLink[®] interface, 125 A, 3-pos., touch-proof and protection against polarity reversal, width: 405 mm

ELR H5-I-PT-24DC/500AC-2-L - Hybrid motor starter



1199926

<https://www.phoenixcontact.com/us/products/1199926>

EM-CPS-TB3/63A - Connection module

1002633

<https://www.phoenixcontact.com/us/products/1002633>



Connection module with integrated spring-loaded terminals for cables from 1.5 to 16 mm², 3-pos., maximum 63 A

EM-CPS-DA-22,5F/16A - Adapter

1002668

<https://www.phoenixcontact.com/us/products/1002668>



Device adapter with fuse holder for 16 A fuse (10x38/Class CC), CrossLink[®] interface and fixed DIN rail

Phoenix Contact 2024 © - all rights reserved
<https://www.phoenixcontact.com>

Phoenix Contact USA
586 Fulling Mill Road
Middletown, PA 17057, United States
(+717) 944-1300
info@phoenixcon.com