



6N137, ICPL2601, ICPL2611



DESCRIPTION

The 6N137, ICPL2601 and ICPL2611 devices each consists of an infrared emitting diode, optically coupled to a high speed integrated photo detector logic gate with a strobable output.

FEATURES

- High Speed 10Mbit/s
- Minimum Common Mode Transient Immunity 10kV/ μ s for ICPL2611
- High AC Isolation Voltage 5000V_{RMS}
- Guaranteed Performance from -40°C to 85°C
- Logic Gate Output
- Pb Free and RoHS Compliant
- UL File E91231 for 6N137 and ICPL2601
- VDE File 40044376 for 6N137
- Safety Approvals Pending for ICPL2611

APPLICATIONS

- Line Receivers, Data Communication
- LSTTL to TTL, LSTTL or 5V CMOS
- Data Multiplexing
- Pulse Transformer Replacement
- Switch Mode Power Supplies
- Ground Loop Elimination
- Computer Peripheral Interface

ORDER INFORMATION

- Add V after PN for VDE Approval for 6N137 only
- Add G after PN for 10mm Lead Spacing
- Add SM after PN for Surface Mount
- Add SMT&R after PN for Surface Mount Tape & Reel

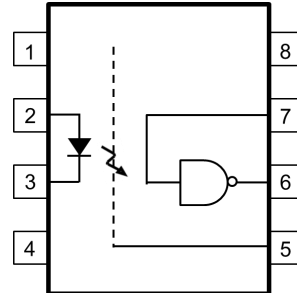

1	NC
2	Anode
3	Cathode
4	NC
5	GND
6	V _O
7	V _E
8	V _{CC}

A 0.1 μ F bypass Capacitor must be connected between Pins 8 and 5.

ABSOLUTE MAXIMUM RATINGS (T_A = 25°C)

Stresses exceeding the absolute maximum ratings can cause permanent damage to the device. Exposure to absolute maximum ratings for long periods of time can adversely affect reliability.

Input

Forward Current	50mA
Reverse Voltage	5V
Power dissipation	100mW

Output

Output Current	50mA
Output Voltage	7.0V
Supply Voltage	7.0V
Enable Input Voltage (maximum 500mV above V _{CC})	5.5V
Power Dissipation	85mW

Total Package

Isolation Voltage	5000V _{RMS}
Total Power Dissipation	100mW
Operating Temperature	-40 to 85°C
Storage Temperature	-55 to 125°C
Lead Soldering Temperature (10s)	260°C

ISOCOM COMPONENTS 2004 LTD

Unit 25B, Park View Road West, Park View Industrial Estate
Hartlepool, Cleveland, TS25 1PE, United Kingdom
Tel : +44 (0)1429 863 609 Fax : +44 (0)1429 863 581
e-mail : sales@isocom.co.uk
<http://www.isocom.com>

ISOCOM COMPONENTS ASIA LTD

Hong Kong Office
Block A, 8/F, Wah Hing Industrial Mansion
36 Tai Yau Street, San Po Kong, Kowloon, Hong Kong
Tel : +852 2995 9217 Fax : +852 8161 6292
e-mail : sales@isocom.com.hk

Truth Table

Input	Enable	Output
H	H	L
L	H	H
H	L	H
L	L	H
H	NC	L
L	NC	H

6N137, ICPL2601, ICPL2611

ELECTRICAL CHARACTERISTICS ($T_A = -40$ to 85°C unless otherwise specified)

INPUT

Parameter	Symbol	Test Condition	Min	Typ.*	Max	Unit
Forward Voltage	V_F	$I_F = 10\text{mA}$		1.4	1.8	V
Forward Voltage Temperature Coefficient	$\Delta V_F/\Delta T$	$I_F = 10\text{mA}$		-1.8		mV/ $^\circ\text{C}$
Reverse Voltage	V_R	$I_R = 10\mu\text{A}$	5.0			V
Input Capacitance	C_{IN}	$V_F = 0\text{V}$, $f = 1\text{MHz}$		60		pF

OUTPUT

Parameter	Symbol	Test Condition	Min	Typ.*	Max	Unit
High Level Supply Current	I_{CCH}	$I_F = 0\text{mA}$, $V_{CC} = 5.5\text{V}$ $V_E = 0.5\text{V}$		7	10	mA
Low Level Supply Current	I_{CCL}	$I_F = 10\text{mA}$, $V_{CC} = 5.5\text{V}$		9	13	mA
High Level Output Current	I_{OH}	$I_F = 250\mu\text{A}$, $V_{CC} = 5.5\text{V}$, $V_E = 2.0\text{V}$, $V_O = 5.5\text{V}$		2.1	100	μA
Low Level Output Voltage	V_{OL}	$I_F = 5\text{mA}$, $V_{CC} = 5.5\text{V}$, $V_E = 2.0\text{V}$, $I_{OL} = 13\text{mA}$		0.35	0.6	V
High Level Enable Current	I_{EH}	$V_{CC} = 5.5\text{V}$, $V_E = 2.0\text{V}$		-0.6	-1.6	mA
Low Level Enable Current	I_{EL}	$V_{CC} = 5.5\text{V}$, $V_E = 0.5\text{V}$		-0.8	-1.6	mA
High Level Enable Voltage	V_{EH}	$I_F = 10\text{mA}$, $V_{CC} = 5.5\text{V}$	2.0			V
Low Level Enable Voltage	V_{EL}	$I_F = 10\text{mA}$, $V_{CC} = 5.5\text{V}$			0.8	V

COUPLED

Parameter	Symbol	Test Condition	Min	Typ.*	Max	Unit
Input Threshold Current	I_{FT}	$V_{CC} = 5.5\text{V}$, $V_O = 0.6\text{V}$ $V_E = 2.0\text{V}$, $I_{OL} = 13\text{mA}$		2.5	5	mA

* Typical values at $T_A = 25^\circ\text{C}$

6N137, ICPL2601, ICPL2611

ELECTRICAL CHARACTERISTICS ($T_A = -40$ to 85°C unless otherwise specified)

SWITCHING ($I_F = 7.5\text{mA}$, $V_{CC} = 5\text{V}$ unless otherwise specified)

Parameter	Symbol	Test Condition	Min	Typ.*	Max	Unit
Propagation Delay Time to High Output Level	t_{PLH}	$R_L = 350\Omega$, $C_L = 15\text{pF}$, $T_A = 25^\circ\text{C}$		40	75	ns
Propagation Delay Time to Low Output Level	t_{PHL}			35	75	
Pulse Width Distortion	$ t_{PHL} - t_{PLH} $	$R_L = 350\Omega$, $C_L = 15\text{pF}$		5	35	
Output Rise Time (10% to 90%)	t_r			40		
Output Fall Time (90% to 10%)	t_f			10		
Enable Propagation Delay Time to High Output Level	t_{ELH}	$V_{EH} = 3.5\text{V}$, $R_L = 350\Omega$, $C_L = 15\text{pF}$		15		
Enable Propagation Delay Time to Low Output Level	t_{EHL}			15		

* Typical values at $T_A = 25^\circ\text{C}$

6N137, ICPL2601, ICPL2611

ELECTRICAL CHARACTERISTICS ($T_A = -40$ to 85°C unless otherwise specified)

SWITCHING ($I_F = 7.5\text{mA}$, $V_{CC} = 5\text{V}$ unless otherwise specified)

Parameter	Symbol	Test Condition	Min	Typ.*	Max	Unit
Common Mode Transient Immunity at Logic High	CM _H	6N137 $I_F = 0\text{mA}$, $V_{OH} = 2.0\text{V}$, $R_L = 350\Omega$, $V_{CM} = 10\text{Vp-p}$, $T_A = 25^\circ\text{C}$		5000		V/ μs
		ICPL2601 $I_F = 0\text{mA}$, $V_{OH} = 2.0\text{V}$, $R_L = 350\Omega$, $V_{CM} = 50\text{Vp-p}$, $T_A = 25^\circ\text{C}$	5000			
		ICPL2611 $I_F = 0\text{mA}$, $V_{OH} = 2.0\text{V}$, $R_L = 350\Omega$, $V_{CM} = 400\text{Vp-p}$, $T_A = 25^\circ\text{C}$	10000			
		ICPL2611 High CMR Test Circuit $I_F = 0\text{mA}$, $V_{OH} = 2.0\text{V}$, $R_L = 350\Omega$, $V_{CM} = 400\text{Vp-p}$, $T_A = 25^\circ\text{C}$	20000			
Common Mode Transient Immunity at Logic Low	CM _L	6N137 $I_F = 7.5\text{mA}$, $V_{OL} = 0.8\text{V}$, $R_L = 350\Omega$, $V_{CM} = 10\text{Vp-p}$, $T_A = 25^\circ\text{C}$		5000		V/ μs
		ICPL2601 $I_F = 7.5\text{mA}$, $V_{OL} = 0.8\text{V}$, $R_L = 350\Omega$, $V_{CM} = 50\text{Vp-p}$, $T_A = 25^\circ\text{C}$	5000			
		ICPL2611 $I_F = 7.5\text{mA}$, $V_{OL} = 0.8\text{V}$, $R_L = 350\Omega$, $V_{CM} = 400\text{Vp-p}$, $T_A = 25^\circ\text{C}$	10000			
		ICPL2611 High CMR Test Circuit $I_F = 7.5\text{mA}$, $V_{OL} = 0.8\text{V}$, $R_L = 350\Omega$, $V_{CM} = 400\text{Vp-p}$, $T_A = 25^\circ\text{C}$	20000			

* Typical values at $T_A = 25^\circ\text{C}$

6N137, ICPL2601, ICPL2611

ELECTRICAL CHARACTERISTICS ($T_A = -40$ to 85°C unless otherwise specified)

ISOLATION

Parameter	Symbol	Test Condition	Min	Typ.*	Max	Unit
Insulation Voltage	V_{ISO}	RH = 40% - 60%, $T_A = 25^\circ\text{C}$ $t = 1$ min,	5000			V_{RMS}

* Typical values at $T_A = 25^\circ\text{C}$

Note :

- V_{CC} supply must be bypassed by a $0.1\mu\text{F}$ capacitor or larger with good high frequency characteristic and should be connected as close as possible to the package V_{CC} and GND pins.
- Enable Input – No pull up resistor required as the device has an internal pull up resistor.
- t_{PLH} is measured from the 3.75mA level on the HIGH to LOW transition of the input current pulse to the 1.5 V level on the LOW to HIGH transition of the output voltage pulse.
- t_{PHL} is measured from the 3.75mA level on the LOW to HIGH transition of the input current pulse to the 1.5 V level on the HIGH to LOW transition of the output voltage pulse.
- t_r Rise time is measured from the 10% to the 90% levels on the LOW to HIGH transition of the output pulse.
- t_f Fall time is measured from the 90% to the 10% levels on the HIGH to LOW transition of the output pulse.
- t_{ELH} is measured from the 1.5V level on the HIGH to LOW transition of the input Enable voltage pulse to the 1.5V level on the LOW to HIGH transition of the output voltage pulse.
- t_{EHL} is measured from the 1.5V level on the LOW to HIGH transition of the input Enable voltage pulse to the 1.5V level on the HIGH to LOW transition of the output voltage pulse.
- CM_H – The maximum tolerable rate of rise of the Common Mode voltage to ensure the output will remain in the HIGH state (i.e., $V_O > 2.0\text{V}$).
- CM_L – The maximum tolerable rate of rise of the Common Mode voltage to ensure the output will remain in the LOW output state (i.e., $V_O < 0.8\text{V}$).

6N137, ICPL2601, ICPL2611

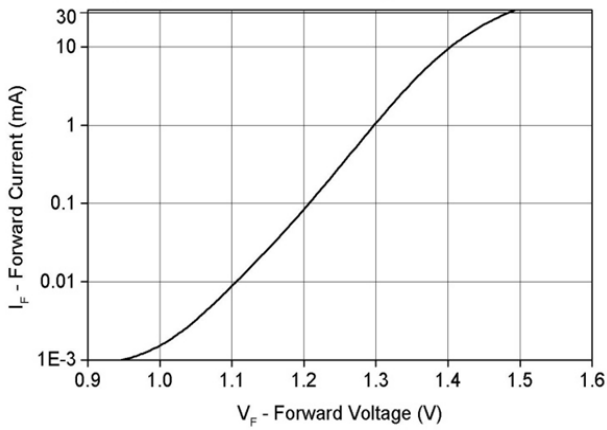

Fig 1 Forward Current vs Forward Voltage

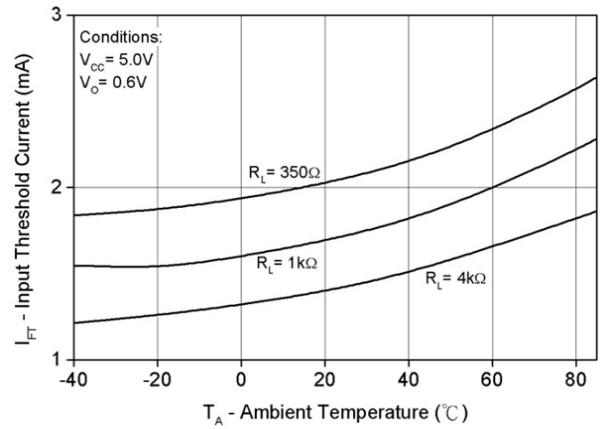

Fig 2 Input Threshold Current vs T_A

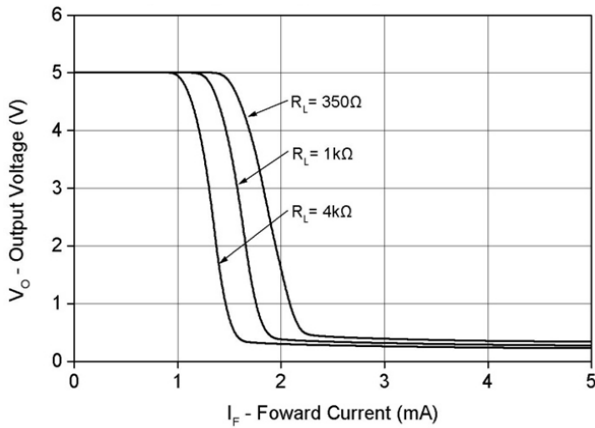

Fig 3 Output Voltage vs Forward Current

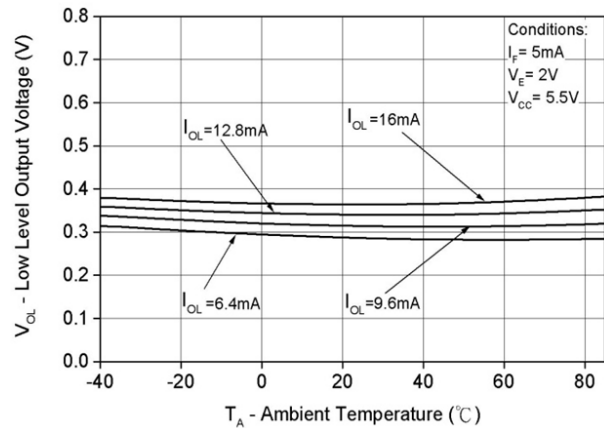

Fig 4 Output Low Level Voltage vs T_A

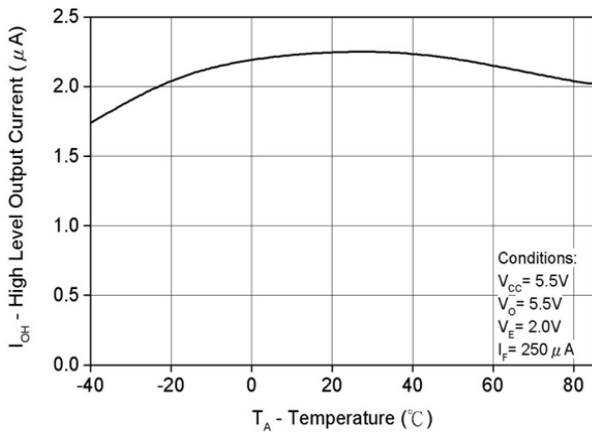

Fig 5 Output High Level Current vs T_A

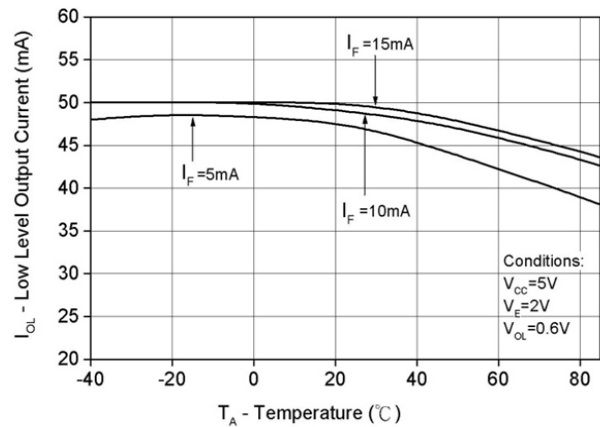

Fig 6 Output Low Level Current vs T_A

6N137, ICPL2601, ICPL2611

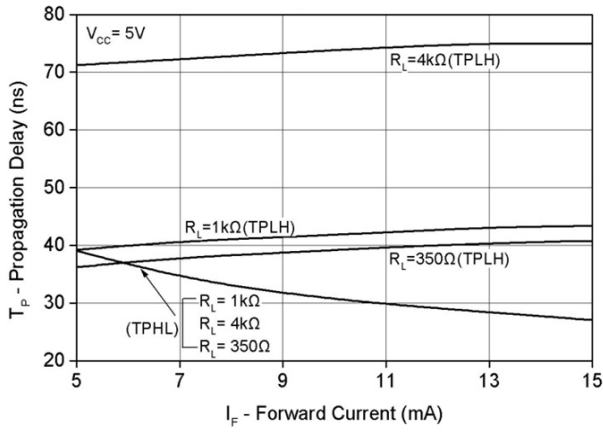

Fig 7 Propagation Delay vs Forward Current

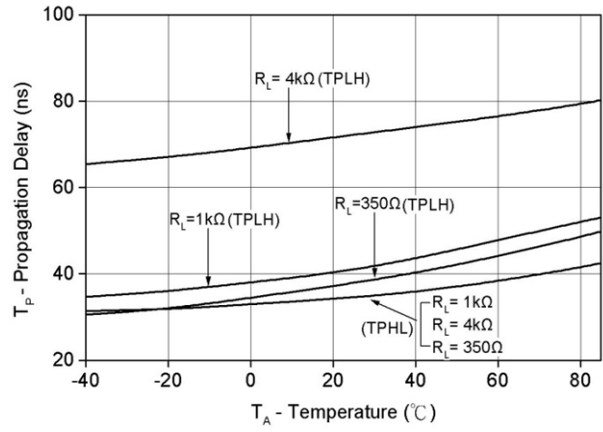

Fig 8 Propagation Delay vs T_A

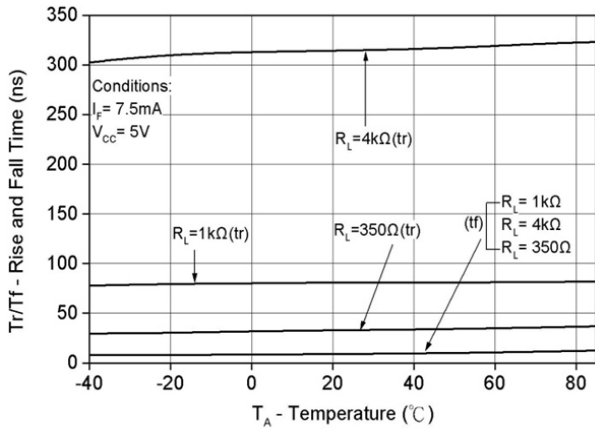

Fig 9 Rise / Fall Time vs T_A

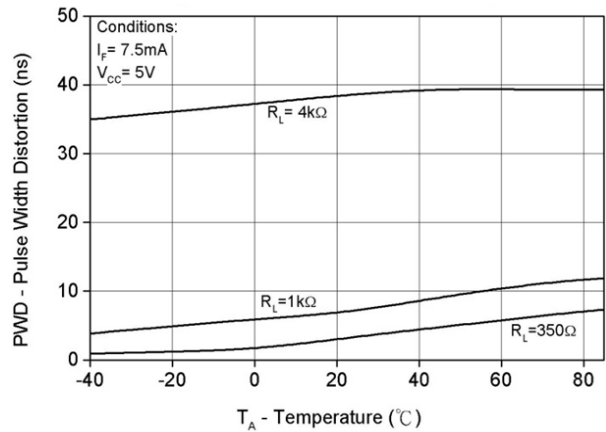

Fig 10 Pulse Width Distortion vs T_A

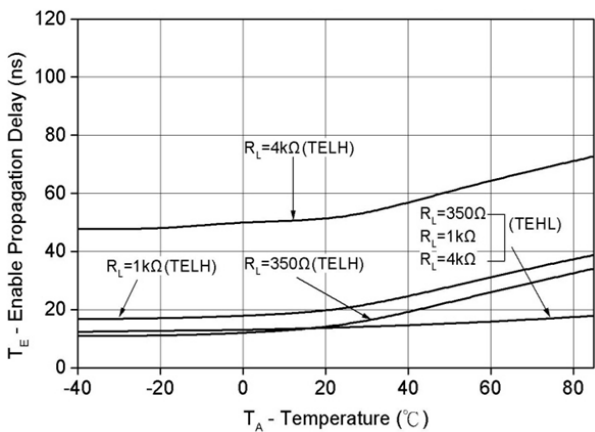
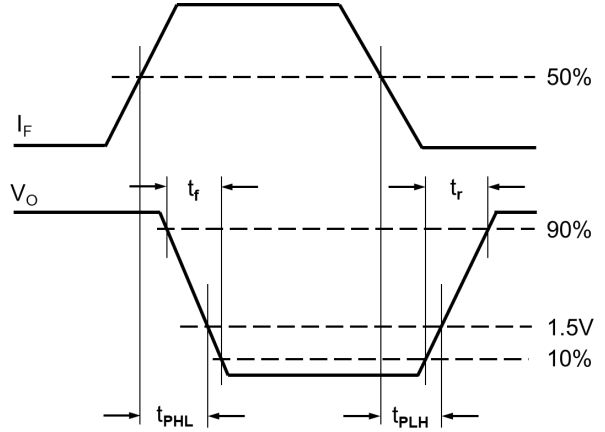
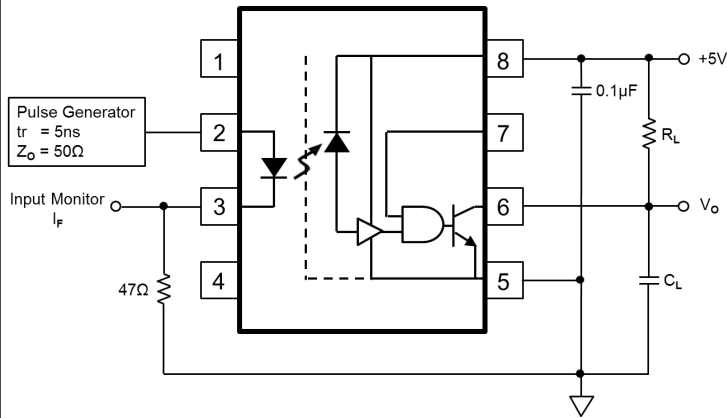
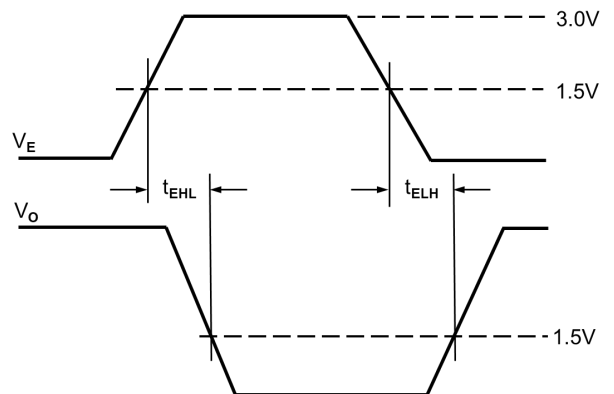
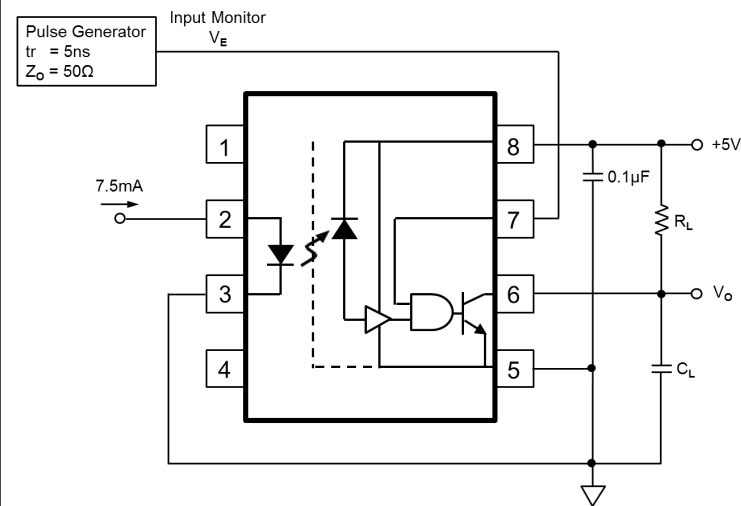

Fig 11 Enable Propagation Delay vs T_A

6N137, ICPL2601, ICPL2611



t_r , t_b , t_{PLH} and t_{PHL} Test Circuit and Waveform



t_{ELH} and t_{EHL} Test Circuit and Waveform

6N137, ICPL2601, ICPL2611

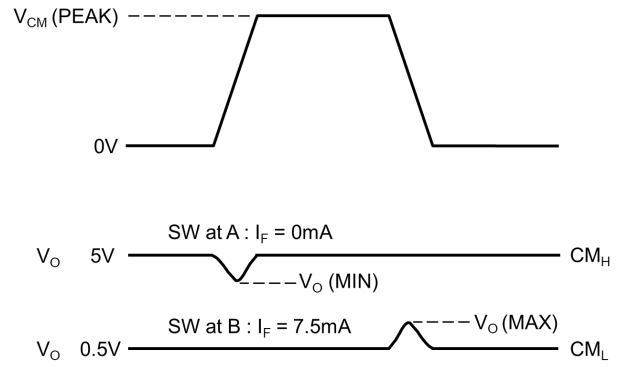
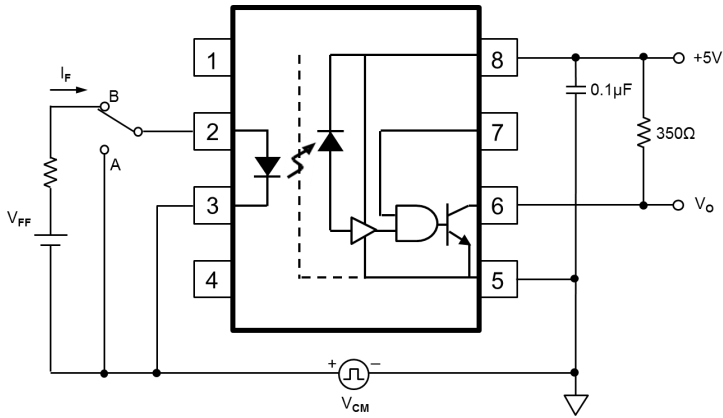

CMR Test Circuit

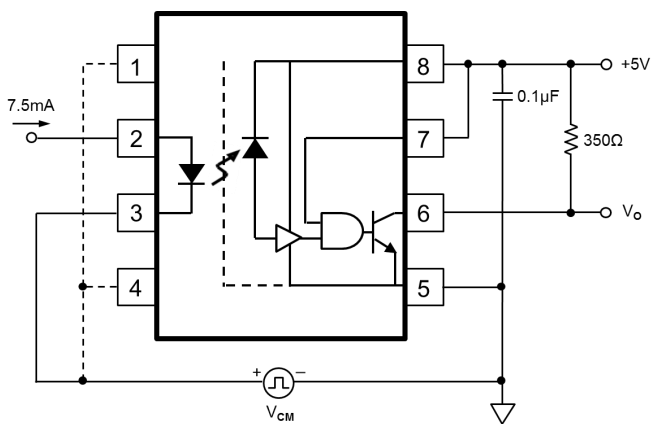

High CMR Test Circuit for ICPL2611

6N137, ICPL2601, ICPL2611

ORDER INFORMATION

UL Approval			
After PN	PN	Description	Packing quantity
None	6N137, ICPL2601	Standard DIP8	45 pcs per tube
G	6N137G, ICPL2601G	10mm Lead Spacing	45 pcs per tube
SM	6N137SM, ICPL2601SM	Surface Mount	45 pcs per tube
SMT&R	6N137SMT&R, ICPL2601SMT&R	Surface Mount Tape & Reel	1000 pcs per reel

NOTE : 6N137V may be supported when ordering 6N137

UL and VDE Approvals			
After PN	PN	Description	Packing quantity
None	6N137V	Standard DIP8	45 pcs per tube
G	6N137VG	10mm Lead Spacing	45 pcs per tube
SM	6N137VSM	Surface Mount	45 pcs per tube
SMT&R	6N137VSMT&R	Surface Mount Tape & Reel	1000 pcs per reel

Safety Approval Pending			
After PN	PN	Description	Packing quantity
None	ICPL2611	Standard DIP8	45 pcs per tube
G	ICPL2611G	10mm Lead Spacing	45 pcs per tube
SM	ICPL2611SM	Surface Mount	45 pcs per tube
SMT&R	ICPL2611SMT&R	Surface Mount Tape & Reel	1000 pcs per reel

DEVICE MARKING

Example : 6N137V

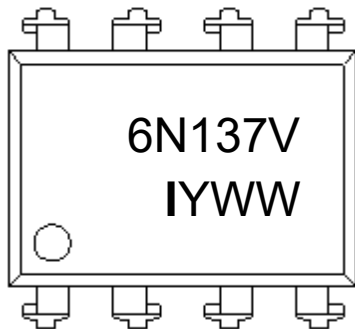

6N137V	Device Part Number
I	Isocom
Y	1 digit Year code
WW	2 digit Week code



6N137, ICPL2601, ICPL2611

PACKAGE DIMENSIONS (mm)

DIP

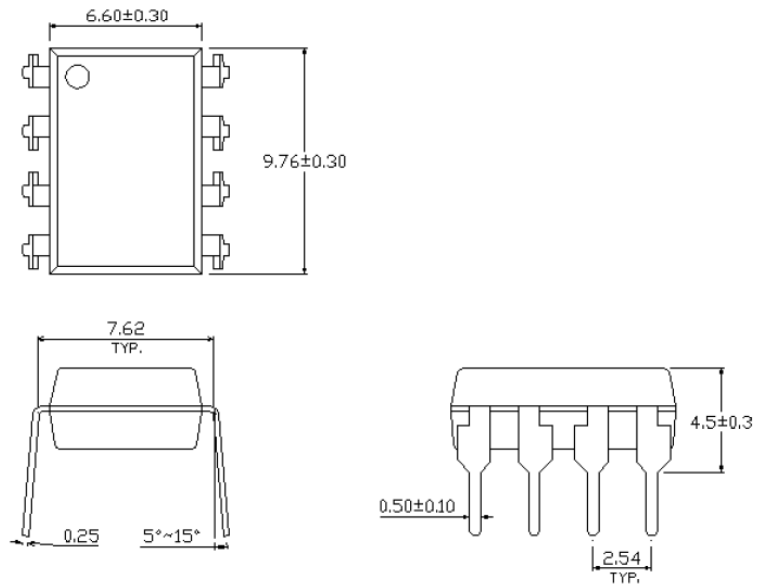

G-Form

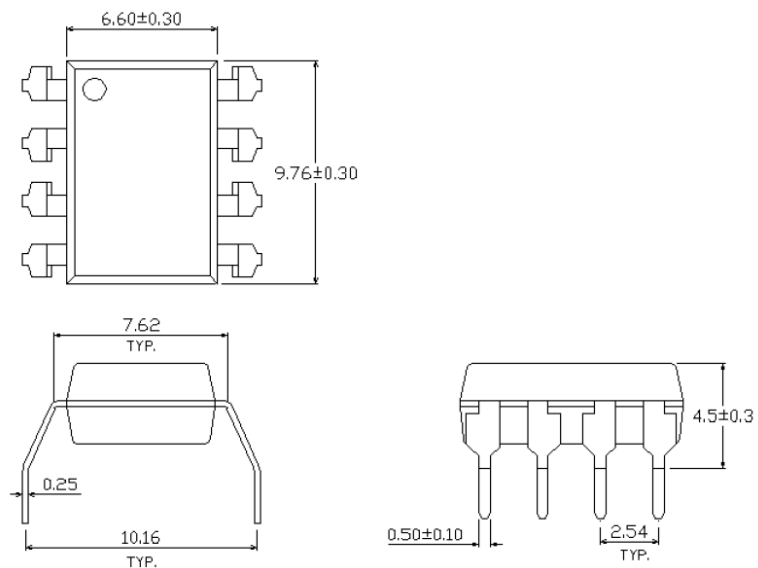

6N137, ICPL2601, ICPL2611

PACKAGE DIMENSIONS (mm)

SMD

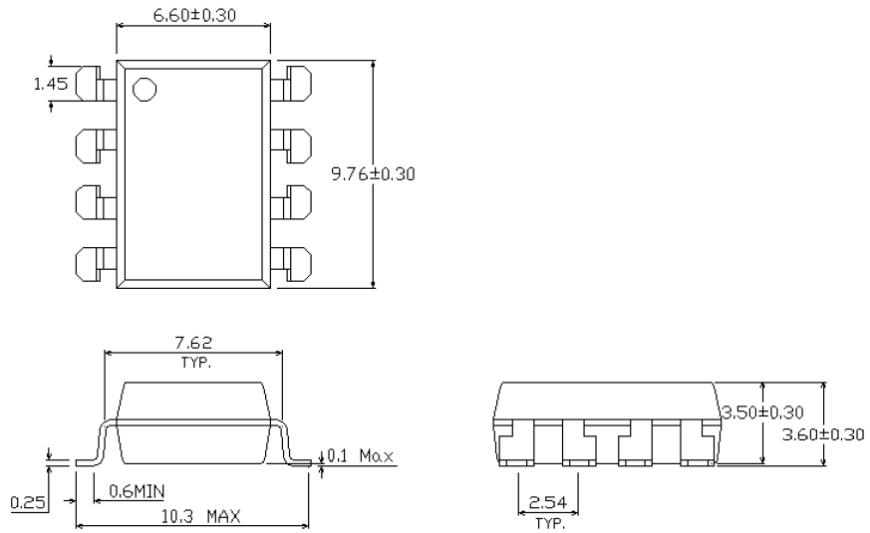

RECOMMENDED PAD LAYOUT FOR SMD (mm)

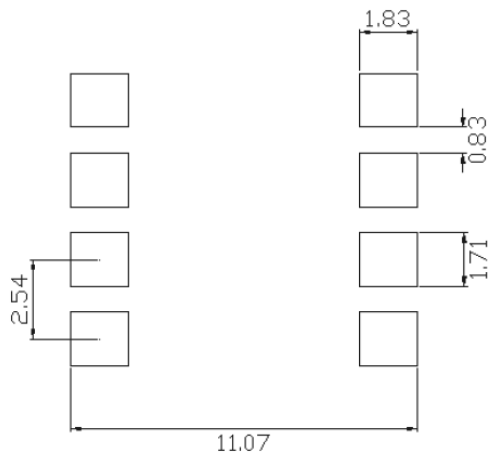



TAPE AND REEL PACKAGING

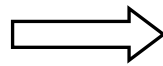
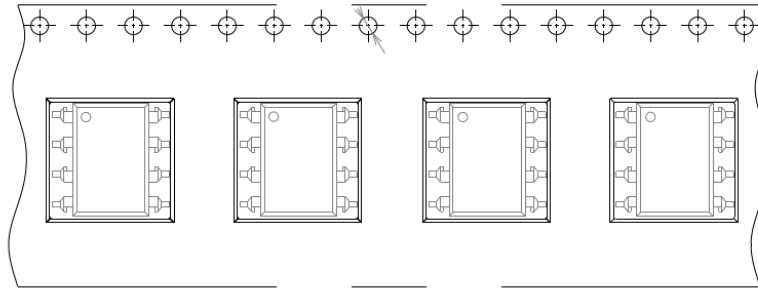

Direction of feed from reel

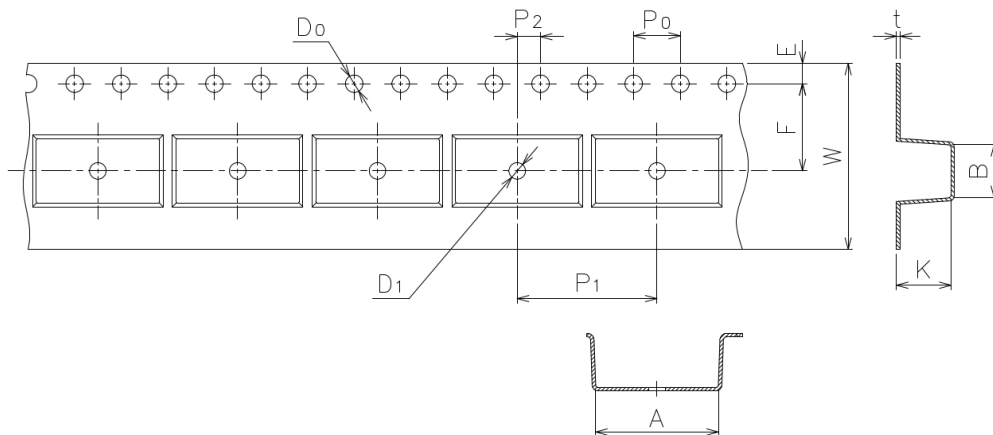

Dimension No.	A	B	D₀	D₁	E	F
Dimension(mm)	10.4±0.1	10.0±0.1	1.5±0.1	1.5±0.1	1.75±0.1	7.5±0.1
Dimension No.	P₀	P₁	P₂	t	W	K
Dimension (mm)	4.0±0.1	12.0±0.1	2.0±0.1	0.4±0.1	16.0 ±0.3 / -0.1	4.5±0.1



6N137, ICPL2601, ICPL2611

IR REFLOW SOLDERING TEMPERATURE PROFILE
One Time Reflow Soldering is Recommended.
Do not immerse device body in solder paste.

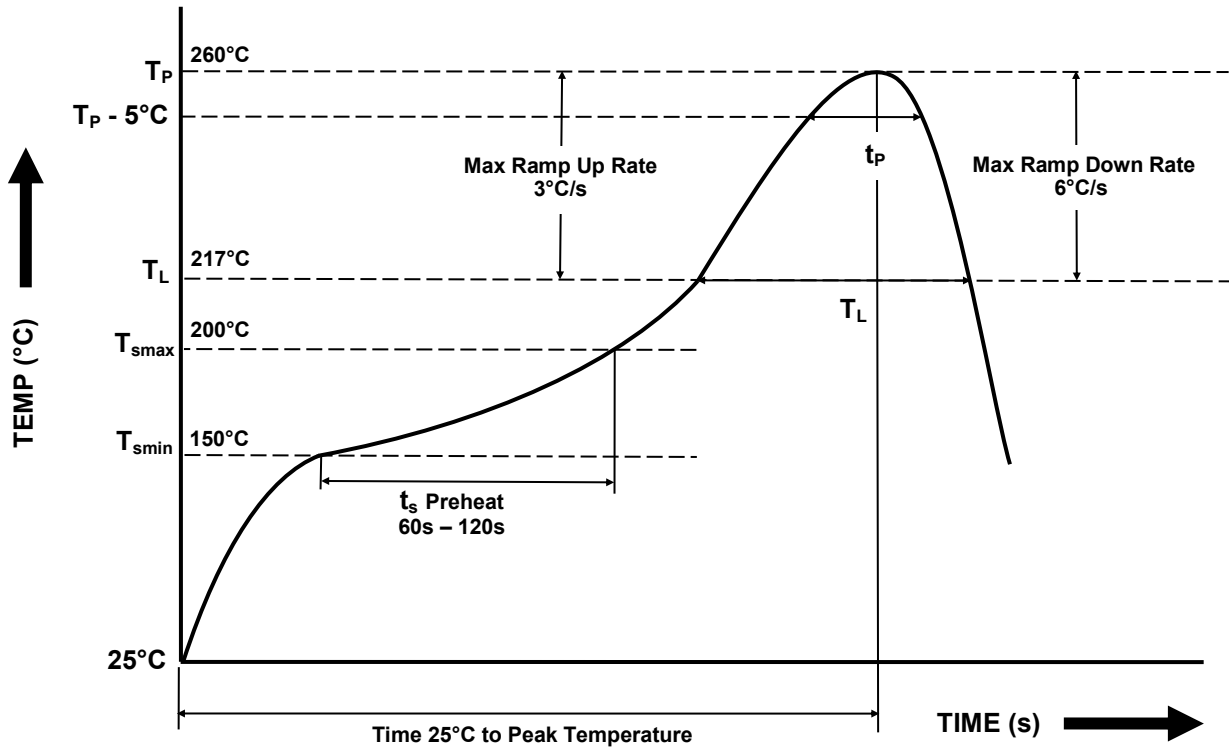

Profile Details	Conditions
Preheat - Min Temperature (T_{SMIN}) - Max Temperature (T_{SMAX}) - Time T_{SMIN} to T_{SMAX} (t_s)	150°C 200°C 60s - 120s
Soldering Zone - Peak Temperature (T_P) - Time at Peak Temperature - Liquidous Temperature (T_L) - Time within 5°C of Actual Peak Temperature ($T_P - 5^\circ\text{C}$) - Time maintained above T_L (t_L) - Ramp Up Rate (T_L to T_P) - Ramp Down Rate (T_P to T_L)	260°C 10s max 217°C 30s max 60s - 100s 3°C/s max 6°C/s max
Average Ramp Up Rate (T_{smax} to T_P)	3°C/s max
Time 25°C to Peak Temperature	8 minutes max



DISCLAIMER

Isocom Components is continually working to improve the quality and reliability of its products. Nevertheless, semiconductor devices in general can malfunction or fail due to their inherent electrical sensitivity and vulnerability to physical stress. It is the responsibility of the buyer, when utilizing Isocom Components products, to comply with the standards of safety in making a safe design for the entire system, and to avoid situations in which a malfunction or failure of such Isocom Components products could cause loss of human life, bodily injury or damage to property.

In developing your designs, please ensure that Isocom Components products are used within specified operating ranges as set forth in the most recent Isocom Components products specifications.

The Isocom Components products listed in this document are intended for usage in general electronics applications (computer, personal equipment, office equipment, measuring equipment, industrial robotics, domestic appliances, etc.). These Isocom Components products are neither intended nor warranted for usage in equipment that requires extraordinarily high quality and/or reliability or a malfunction or failure of which may cause loss of human life or bodily injury ("Unintended Usage"). Unintended Usage include atomic energy control instruments, airplane or spaceship instruments, transportation Instruments, traffic signal instruments, combustion control instruments, medical Instruments, all types of safety devices, etc... Unintended Usage of Isocom Components products listed in this document shall be made at the customer's own risk.

Gallium arsenide (GaAs) is a substance used in the products described in this document. GaAs dust and fumes are toxic. Do not break, cut or pulverize the product, or use chemicals to dissolve them. When disposing of the products, follow the appropriate regulations. Do not dispose of the products with other industrial waste or with domestic garbage.

The products described in this document are subject to the foreign exchange and foreign trade laws.

The information contained herein is presented only as a guide for the applications of our products. No responsibility is assumed by Isocom Components for any infringements of intellectual property or other rights of the third parties which may result from its use. No license is granted by implication or otherwise under any intellectual property or other rights of Isocom Components or others.

The information contained herein is subject to change without notice.