

REVISION BY

DO NOT SCALE FROM THIS PRINT

NOTES:

1. Ⓞ REPRESENTS A CRITICAL DIMENSION.
2. PARTS MAY BE CUT TO POSITION.
3. MAXIMUM CUT FLASH: .010[0.25] ON TAIL SIDE, ALL OTHER AREAS AT .015[0.38]. LOOSE CUT FLASH MUST BE REMOVED.
4. MINIMUM PUSHOUT FORCE: 1.0 LB.
5. TERMINALS TO BE SHEARED TO MEET DIMENSION SPECIFICATION.
6. LAYER PACKAGE 2 - 4 POSITIONS AND TUBE 5 - 50 POSITIONS.
7. MAXIMUM BURR ALLOWANCE: .003[0.08].
8. DUE TO THE HIGH AMOUNT OF INSERTION FORCE NEEDED, THE -EC OPTION IS NOT COMPATIBLE WITH AUTO PLACEMENT. SAMTEC RECOMMENDS MANUAL PLACEMENT FOR ALL ASSEMBLIES WITH THE -EC OPTION.
9. MAXIMUM HEIGHT VARIATION BETWEEN ROWS: .005[0.13].
10. VOIDS MAY OR MAY NOT BE PRESENT ON POSITIONS 5 THROUGH 8 AND CAN BE MIXED WITHIN AN ORDER.

FTSH-1XX-XX-XXX-D-XXX-XX

No OF POSITIONS

-02 THRU -50
(PER ROW)

LEAD STYLE

- 01: .120 [3.05]
- 02: .075 [1.91]
- 03: .065 [1.65]
- 04: .150 [3.81]

PLATING SPECIFICATION

- G: 10μ" GOLD IN CONTACT AREA, 3μ" GOLD ON TAIL
- F: 3μ" FLASH SELECTIVE GOLD IN CONTACT AREA, MATTE TIN ON TAIL
- L: 10μ" LIGHT SELECTIVE GOLD IN CONTACT AREA, MATTE TIN ON TAIL
- S: 30μ" SELECTIVE GOLD IN CONTACT AREA, MATTE TIN ON TAIL
- H: 30μ" HEAVY GOLD IN CONTACT AREA, 3μ" GOLD ON TAIL
- FM: 3μ" FLASH SELECTIVE GOLD IN CONTACT AREA, MATTE TIN ON TAIL
- LM: 10μ" LIGHT SELECTIVE GOLD IN CONTACT AREA, MATTE TIN TAIL
- SM: 30μ" SELECTIVE GOLD IN CONTACT AREA, MATTE TIN ON TAIL
- LTL: 10μ" LIGHT GOLD IN CONTACT AREA, TIN/LEAD (90/10 +/-5%) ON TAIL
- STL: 30μ" SELECTIVE GOLD IN CONTACT AREA, TIN/LEAD (90/10 +/-5%) ON TAIL

OPTIONS

- ES: END SHROUDS (SEE FIG 2, SHT 2)
(MOLDED 5 POS MIN; -02 & -03 LEAD STYLE ONLY)
(MUST USE FTSH-XX-ES-XX-X)
(SNAP SHROUDS 9 POS MIN; -02 & -03 LEAD STYLE ONLY)
(MUST USE FTSH-50-D)
- EJ: EJECTOR SHROUDS: (SEE FIG 3, SHT 2)
(10 POS MIN; -01 LEAD STYLE ONLY)
(MUST USE FTSH-50-D)
- EC: LOCKING CLIP (SEE FIG 4, SHT 2; SEE NOTE 8)
(9 POS MIN; -02 & -03 LEAD STYLES ONLY)
(MUST USE FTSH-50-D)
- EP: GUIDE POST (SEE FIG 5, SHT 2)
(9 POS MIN; -02 & -03 LEAD STYLES ONLY)
(USE ONLY WHEN MATING WITH CLP)
(MUST USE FTSH-50-D)
- EL: BOARD LOCKS (SEE FIG 6, SHT 2)
(9 POS MIN; -02 & -03 LEAD STYLES ONLY)
(USE ONLY WHEN MATING WITH CLP)
(MUST USE FTSH-50-D)
- K: KEYING OPTION FOR MATING WITH FFSD
(05 THRU 25 ONLY)
(POSITION 13, 17, 20 & 25 AVAILABLE WITH -EJ OPTION)
(LEAD STYLE -01 ONLY, SEE FIG 7, SHT 3)
(MUST USE FTSH-XX-CN-XX)
- LC: LOCKING CLIP: (SEE FIG 8, SHT 3)
(5 POS MIN, ONLY AVAILABLE IN -01 LEAD STYLE)
(IN COMBINATION WITH -K, USE FTSH-XX-CN-XX,
10 POSITION MINIMUM, ONLY AVAILABLE IN
-01 LEAD STYLE)
(MUST USE FTSH-50-D)
(SINGLE MATING CYCLE ONLY)
(MUST BE MATED TO SAMTEC FFSD SERIES)

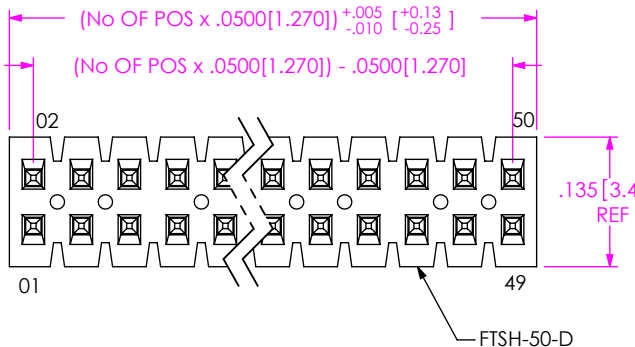

ROW SPECIFICATION

-D: DOUBLE ROW

POLARIZING OPTION

XXX INDICATES POSITION TO BE OMITTED
(NOT AVAILABLE WITH EX OPTIONS)
(ONLY AVAILABLE WITH -F, -FM, -L, -LM PLATING OPTIONS)

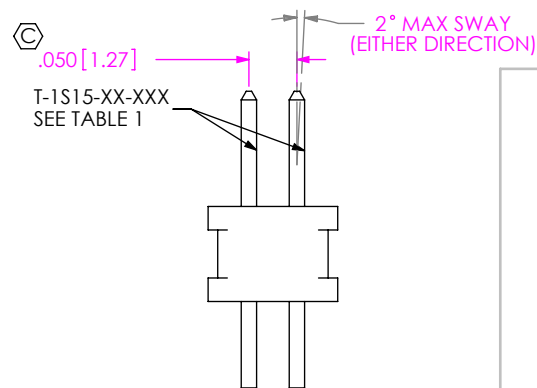
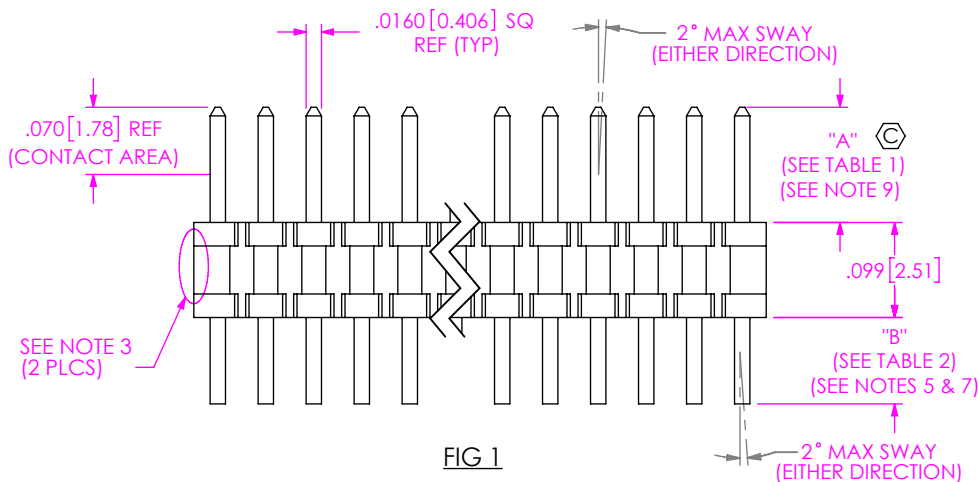

TABLE 2

| OPTIONS | "B" |
|------------|-----------|
| NONE | .09 [2.3] |
| -ES, -EC | .09 [2.3] |
| -EJ, -EJ-K | .11 [2.7] |
| -EP | .09 [2.3] |
| -EL | .09 [2.3] |
| -K | .09 [2.3] |
| -LC, -K-LC | .12 [3.0] |

TABLE 1

| LEAD STYLE | "A" | TERMINAL | "C" REF |
|------------|-------------|--------------|--------------|
| -01 | .120 [3.05] | T-1S15-02-XX | .350 [8.89] |
| -02 | .075 [1.91] | T-1S15-02-XX | .350 [8.89] |
| -03 | .065 [1.65] | T-1S15-04-XX | .450 [11.43] |
| -04 | .150 [3.81] | T-1S15-04-XX | .450 [11.43] |

UNLESS OTHERWISE SPECIFIED, DIMENSIONS ARE IN INCHES. TOLERANCES ARE:
DECIMALS ANGLES
.XX: ±.01 [.3] 1°
.XXX: ±.005 [.13]
.XXXX: ±.0010 [.025]

PROPRIETARY NOTE
THIS DOCUMENT CONTAINS CONFIDENTIAL AND PROPRIETARY INFORMATION AND ALL DESIGN, MANUFACTURING, REPRODUCTION, USE, PATENT RIGHTS AND SALES RIGHTS ARE EXPRESSLY RESERVED BY SAMTEC, INC. THIS DOCUMENT SHALL NOT BE DISCLOSED, IN WHOLE OR PART, TO ANY UNAUTHORIZED PERSON OR ENTITY NOR REPRODUCED, TRANSFERRED OR INCORPORATED IN ANY OTHER PROJECT IN ANY MANNER WITHOUT THE EXPRESS WRITTEN CONSENT OF SAMTEC, INC.

MATERIAL: DO NOT SCALE DRAWING SHEET SCALE: 5:1
INSULATOR: LCD UL 94-V0
TERMINAL: PHOSPHOR BRONZE

samtec
520 PARK EAST BLVD, NEW ALBANY, IN 47150
PHONE: 812-944-6733 FAX: 812-948-5047
e-Mail: info@SAMTEC.com code 53322

DESCRIPTION:
.050 x .050 CL THROUGH HOLE TERMINAL STRIP
DWG. NO.
FTSH-1XX-XX-XXX-D-XXX-XX
BY: J. FERRY 02/27/1996 SHEET 1 OF 3

REVISION BY

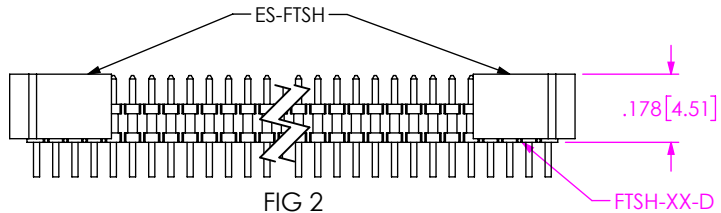
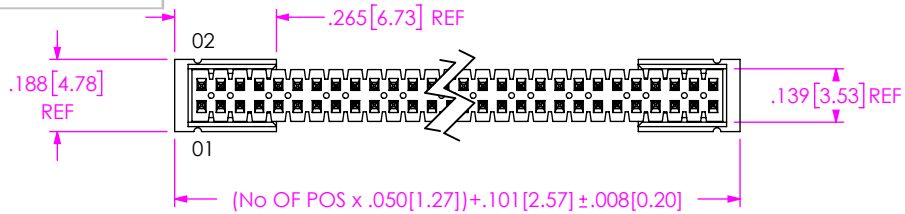
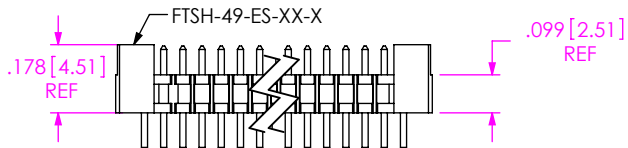
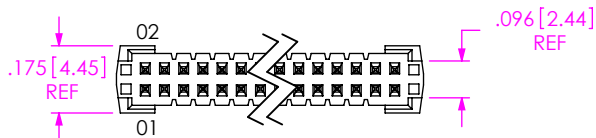

FIG 2
-ES OPTION
(DIFFERENT AS SHOWN, OTHERWISE SAME AS FIG 1)
(-02 OR -03 LEAD STYLE ONLY)
(9 POS MIN FOR SNAP SHROUDS)
(5 POS MIN FOR MOLDED SHROUDS)



(MOLDED SHROUDS)

FIG 3
-EJ OPTION
(DIFFERENT AS SHOWN, OTHERWISE SAME AS FIG 1)
(-01 LEAD STYLE ONLY)

USE SUB-FTSH-EJEHA
(2 REQ'D PER ASSEMBLY
EACH USES 1 EHA-02,
1 FTSH-EJ)

POST SIDE OF CONNECTOR

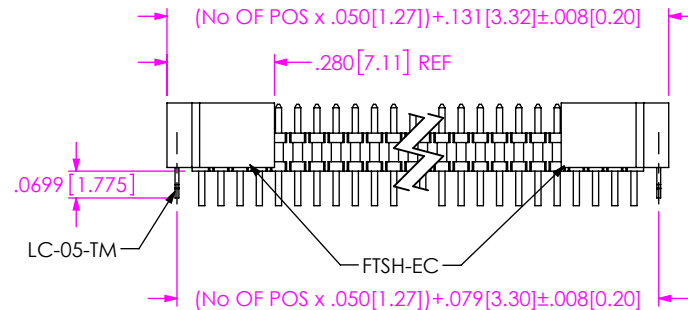
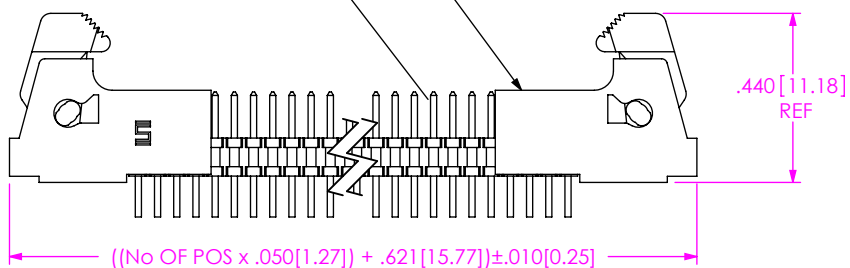

FIG 4
-EC OPTION
(DIFFERENT AS SHOWN, OTHERWISE SAME AS FIG 2)

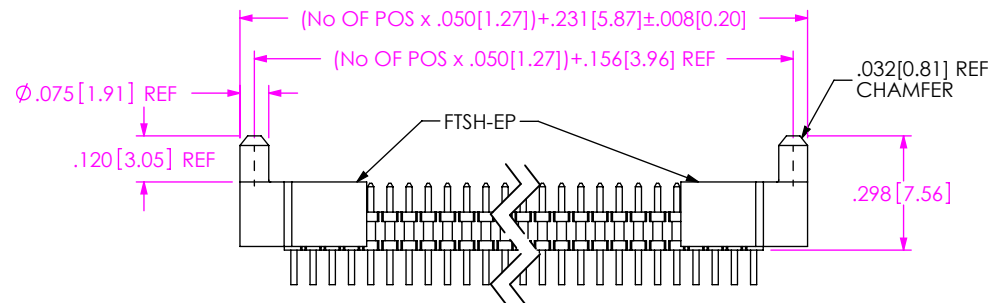

FIG 5
-EP OPTION
(DIFFERENT AS SHOWN, OTHERWISE SAME AS FIG 2)
(USE ONLY WHEN MATING WITH CLP)

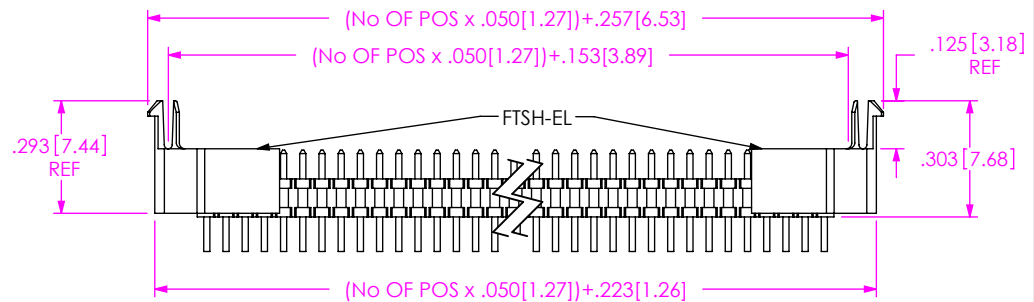
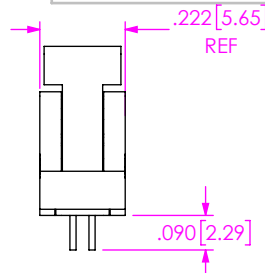

FIG 6
-EL OPTION
(DIFFERENT AS SHOWN, OTHERWISE SAME AS FIG 2)
(USE ONLY WHEN MATING WITH CLP)



F:\DWG\MISC\MKTG\FTSH-1XX-XX-XXX-D-XXX-XX-MKT.SLDDRW

PROPRIETARY NOTE
THIS DOCUMENT CONTAINS CONFIDENTIAL AND PROPRIETARY INFORMATION AND ALL DESIGN, MANUFACTURING, REPRODUCTION, USE, PATENT RIGHTS AND SALES RIGHTS ARE EXPRESSLY RESERVED BY SAMTEC, INC. THIS DOCUMENT SHALL NOT BE DISCLOSED, IN WHOLE OR PART, TO ANY UNAUTHORIZED PERSON OR ENTITY NOR REPRODUCED, TRANSFERRED OR INCORPORATED IN ANY OTHER PROJECT IN ANY MANNER WITHOUT THE EXPRESS WRITTEN CONSENT OF SAMTEC, INC.

DO NOT SCALE DRAWING

SHEET SCALE: 2:1

samtec

520 PARK EAST BLVD, NEW ALBANY, IN 47150
PHONE: 812-944-6733 FAX: 812-948-5047
e-Mail info@SAMTEC.com code 53322

DESCRIPTION:
.050 x .050 CL THROUGH HOLE TERMINAL STRIP

DWG. NO.
FTSH-1XX-XX-XXX-D-XXX-XX

BY: J. FERRY 02/27/1996 SHEET 2 OF 3

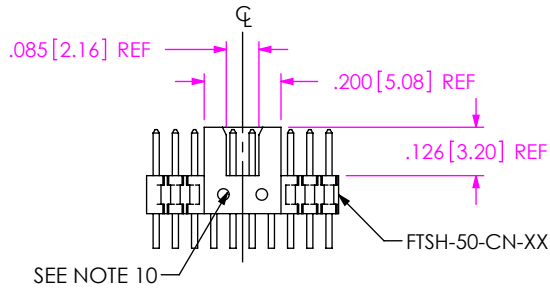
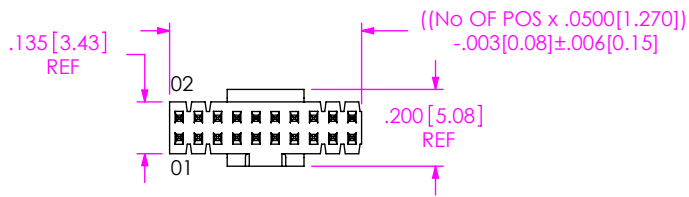

FIG 7
-K OPTION
(LEAD STYLE -01)
(DIFFERENT AS SHOWN, OTHERWISE SAME AS FIG 1)
(POSITION 13, 17, 20 & 25 AVAILABLE WITH -K & -EJ OPTION)

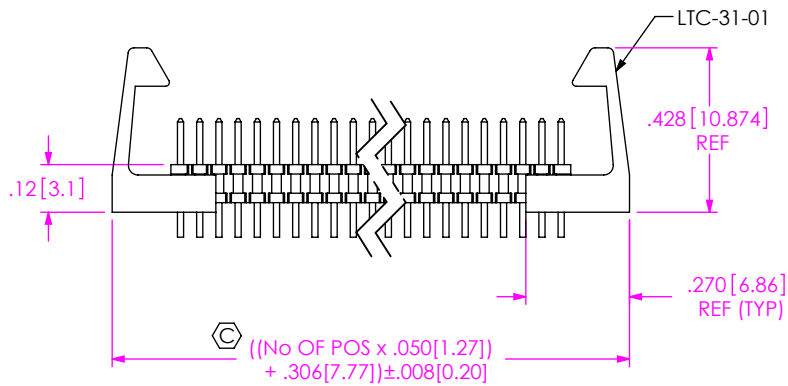

FIG 8
-LC OPTION
(LEAD STYLE -01)
(DIFFERENT AS SHOWN, OTHERWISE SAME AS FIG 1)

TABLE 3
(SEE NOTE 6)

| LEAD STYLE | OPTION(S) | PACKAGING TUBE | TUBE PLUG |
|---------------|------------------------|----------------|-----------|
| -01, -02, -03 | NONE | PT-1-24-01-43 | TP-24 |
| -04 | NONE | PT-1-24-11-09 | TP-09 |
| ALL | -EJ, -EJ-K, -LC, -K-LC | PT-1-24-05-09 | TP-07 |
| ALL | -EC, -EC-K | PT-1-24-01-38 | TP-24 |
| ALL | -EL, -EP, -EL-K, -EP-K | PT-1-24-03-09 | TP-09 |
| ALL | -K | PT-1-24-11-09 | TP-09 |
| ALL | -ES, -ES-K | PT-1-24-01-55 | TP-24 |

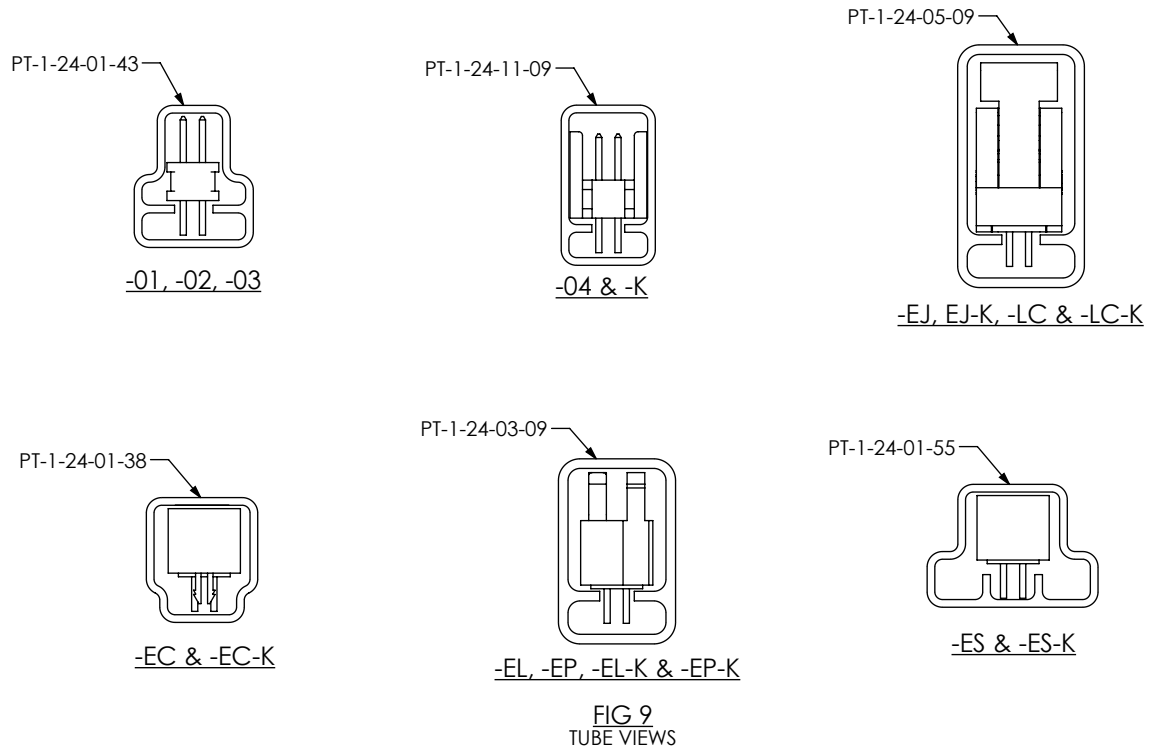

FIG 9
TUBE VIEWS

F:\DWG\MISC\MKTG\FTSH-1XX-XX-XXX-D-XXX-XX-MKT.SLDDRW

PROPRIETARY NOTE
THIS DOCUMENT CONTAINS CONFIDENTIAL AND PROPRIETARY INFORMATION AND ALL DESIGN, MANUFACTURING, REPRODUCTION, USE, PATENT RIGHTS AND SALES RIGHTS ARE EXPRESSLY RESERVED BY SAMTEC, INC. THIS DOCUMENT SHALL NOT BE DISCLOSED, IN WHOLE OR PART, TO ANY UNAUTHORIZED PERSON OR ENTITY NOR REPRODUCED, TRANSFERRED OR INCORPORATED IN ANY OTHER PROJECT IN ANY MANNER WITHOUT THE EXPRESS WRITTEN CONSENT OF SAMTEC, INC.

DO NOT SCALE DRAWING

SHEET SCALE: 2:1



520 PARK EAST BLVD, NEW ALBANY, IN 47150
PHONE: 812-944-6733 FAX: 812-948-5047
e-Mail info@SAMTEC.com code 53322

DESCRIPTION:
.050 x .050 CL THROUGH HOLE TERMINAL STRIP

DWG. NO.
FTSH-1XX-XX-XXX-D-XXX-XX

BY: J. FERRY 02/27/1996 SHEET 3 OF 3