



# Embedded Pentium<sup>®</sup> Processor with MMX<sup>™</sup> Technology

200 MHz, 233 MHz

Datasheet

## Product Features

- Support for MMX<sup>™</sup> Technology
- Compatible with Large Software Base
  - MS-DOS\*, Windows\*, OS/2\*, UNIX\*
- 32-Bit Processor with 64-Bit Data Bus
- Superscalar Architecture
  - Enhanced Pipelines
  - Two Pipelined Integer Units Capable of Two Instructions per Clock
  - Pipelined MMX Technology Unit
  - Pipelined Floating-Point Unit
- Separate Code and Data Caches
  - 16-Kbyte Code, 16-Kbyte Write Back Data
  - MESI Cache Protocol
- Advanced Design Features
  - Deeper Write Buffers
  - Enhanced Branch Prediction Feature
  - Virtual Mode Extensions
- Enhanced CMOS Silicon Technology
- 4-Mbyte Pages for Increased TLB Hit Rate
- IEEE 1149.1 Boundary Scan
- Dual Processing Configuration
- Internal Error Detection Features
- Multiprocessor Support
  - Multiprocessor Instructions
  - Support for Second Level Cache
- On-Chip Local APIC Controller
  - Multiprocessor Interrupt Management
  - 8259 Compatible
- Power Management Features
  - System Management Mode
  - Clock Control
- Fractional Bus Operation
  - 233 MHz Core/66 MHz Bus (iCOMP<sup>®</sup> Index 2.0 rating=203)<sup>†</sup>
  - 200 MHz Core/66 MHz Bus (iCOMP<sup>®</sup> Index 2.0 rating=182)<sup>†</sup>
- Plastic Pin Grid Array Package

<sup>†</sup>Contact Intel Corporation for more information about iCOMP<sup>®</sup> Index 2.0 ratings.

The Pentium<sup>®</sup> processor with MMX<sup>™</sup> technology provides the performance needed for embedded applications. The Pentium processor with MMX technology is compatible with the entire installed base of applications for MS-DOS\*, Windows\*, OS/2\* and UNIX\*. The Pentium processor with MMX technology supports Intel's MMX technology. The Pentium processor with MMX technology superscalar architecture can execute two instructions per clock cycle. Enhanced branch prediction, a pipelined floating-point unit and separate caches provide high performance. Separate code and data caches reduce cache conflicts while remaining software transparent. The Pentium processor with MMX technology has 4.5 million transistors and is built on Intel's enhanced CMOS silicon technology.

Order Number: 273214-001  
November 1998

## ***Revision History***

---

<b>Date</b>	<b>Revision</b>	<b>Description</b>
11/98	001	This is the first publication of this document.

## 1.0 Architecture Overview

---

The embedded Pentium® processor with MMX™ technology is binary compatible with the 8086/8088, 80286, Intel386™, and Intel486™ processor families, and with other Pentium processors. The embedded Pentium processor family includes the following products.

- Pentium processor
- Pentium processor with Voltage Reduction Technology
- Pentium processor with MMX technology
- Low-Power embedded Pentium processor with MMX technology

The Pentium processor family supports the features of previous Intel Architecture processors, and provides significant enhancements and additions including the following:

- Superscalar architecture
- Dynamic branch prediction
- Pipelined floating-point unit
- Improved instruction execution time
- Separate code and data caches
- Writeback MESI protocol in the data cache
- 64-bit data bus
- Bus cycle pipelining
- Address parity
- Internal parity checking
- Execution tracing
- Performance monitoring
- IEEE 1149.1 boundary scan
- System Management Mode
- Virtual Mode extensions
- Dual processing support
- On-chip local APIC device

In addition to the features listed above, the Pentium processor with MMX technology offers the following enhancements over the Pentium processor:

- Support for Intel® MMX technology
- Doubled code and data cache sizes to 16 Kbytes each
- Improved branch prediction
- Enhanced pipeline
- Deeper write buffers

The following features are supported by the Pentium processor, but these features are not supported by the Pentium processor with MMX technology:

- Functional redundancy check and Lock-Step operation.
- Support for Intel 82498/82493 and 82497/82492 cache chipset products
- Split-line accesses to the code cache

For a more detailed description of the Pentium processor family products, please refer to the *Embedded Pentium® Processor Family Developer's Manual* (order number 273204).

## 1.1 Pentium® Processor Family Architecture

The application instruction set of the Pentium processor family includes the complete Intel486 processor family instruction set with extensions to accommodate some of the additional functionality of the Pentium processor. All application software written for the Intel386 and Intel486 family of microprocessors runs on Pentium processors without modification. The on-chip memory management unit (MMU) is completely compatible with the Intel386 family and Intel486 family of processors.

Pentium processors implement several enhancements to increase performance. The two instruction pipelines and the floating-point unit are capable of independent operation. Each pipeline issues frequently used instructions in a single clock. Together, the dual pipes can issue two integer instructions in one clock, or one floating-point instruction (under certain circumstances, two floating-point instructions) in one clock.

Branch prediction is implemented in Pentium processors. To support this, the processor has two prefetch buffers: one prefetches code in a linear fashion and the other prefetches code according to the BTB so the needed code is almost always prefetched before it is needed for execution.

The floating-point unit (FPU) is up to ten times faster than the FPU used on the Intel486 processor for common operations including add, multiply, and load.

Pentium processors include separate code and data caches that are integrated on-chip to meet performance goals. Each cache has a 32-byte line size. Each cache has a dedicated Translation Lookaside Buffer (TLB) to translate linear addresses to physical addresses. The data cache is configurable to be write back or write through on a line-by-line basis and follows the MESI protocol. The data cache tags are triple-ported to support two data transfers and an inquire cycle in the same clock. The code cache is an inherently write-protected cache. The code cache tags are multi-ported to support snooping. Individual pages can be configured as cacheable or non-cacheable by software or hardware. The caches can be enabled or disabled by software or hardware.

Pentium processors have a 64-bit data bus for fast data transfer. Burst read and burst writeback cycles are supported. In addition, bus cycle pipelining allows two bus cycles to occur simultaneously. The Memory Management Unit contains optional extensions to the architecture which allow 4-Kbyte and 4-Mbyte page sizes.

Pentium processors have added significant data integrity and error detection capability. Data parity checking is still supported on a byte-by-byte basis. Address parity checking and internal parity checking features have been added along with a new exception, the machine check exception.

As more and more functions are integrated on chip, the complexity of board level testing is increased. To address this, Pentium processors have increased test and debug capability. Pentium processors implement IEEE Boundary Scan (Standard 1149.1). In addition, Pentium processors provide four breakpoint pins that correspond to each of the debug registers and externally indicate a breakpoint match. Execution tracing provides external indications when an instruction has completed execution in either of the two internal pipelines, or when a branch has been taken.

System Management Mode (SMM) has been implemented along with some extensions to the SMM architecture. Enhancements to the virtual 8086 mode have been made to increase performance by reducing the number of times it is necessary to trap to a virtual 8086 monitor.

Figure 1 is a block diagram of the embedded Pentium processor with MMX technology.

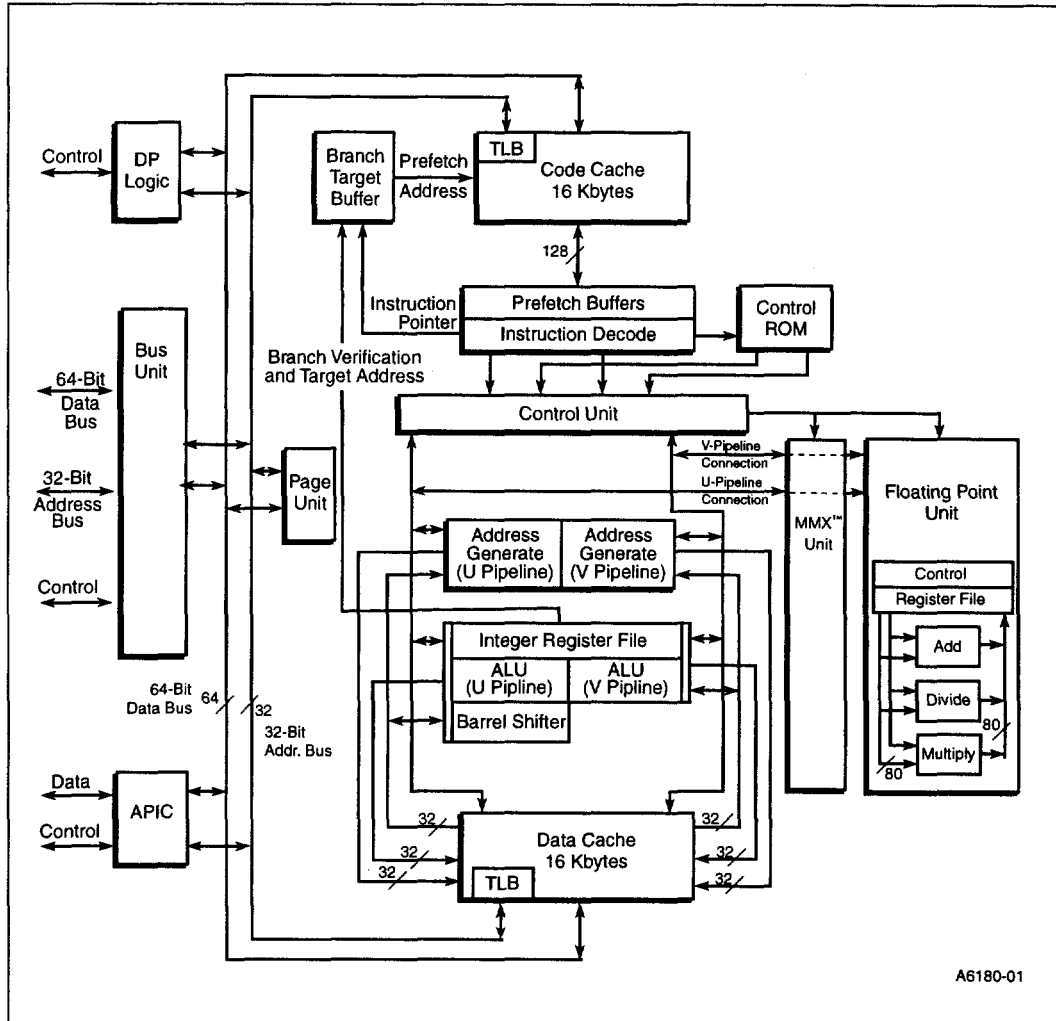
**Figure 1. Pentium® Processor with MMX™ Technology Block Diagram**

The block diagram shows the two instruction pipelines, the “u” pipe and the “v” pipe. The u-pipe can execute all integer and floating-point instructions. The v-pipe can execute simple integer instructions and the FXCH floating-point instructions.

The separate code and data caches are shown in the block diagram. The data cache has two ports, one for each of the two pipes (the tags are triple-ported to allow simultaneous inquire cycles). The data cache has a dedicated Translation Lookaside Buffer (TLB) to translate linear addresses to the physical addresses used by the data cache.

The code cache, branch target buffer and prefetch buffers are responsible for getting raw instructions into the execution units. Instructions are fetched from the code cache or from the external bus. Branch addresses are remembered by the branch target buffer. The code cache TLB translates linear addresses to physical addresses used by the code cache.

The decode unit decodes the prefetched instructions so the processor can execute the instruction. The control ROM contains microcode to control the sequence of operations that must be performed to implement the Pentium processor architecture. The control ROM unit has direct control over both pipelines.

Pentium processors contain a pipelined floating-point unit that provides a significant floating-point performance advantage over previous generations of processors.

Symmetric dual processing in a system is supported with two Pentium processors. The two processors appear to the system as a single Pentium processor. Operating systems with dual processing support properly schedule computing tasks between the two processors. This scheduling of tasks is transparent to software applications and the end-user. Logic built into the processors support a “glueless” interface for easy system design. Through a private bus, the two Pentium processors arbitrate for the external bus and maintain cache coherency. Dual processing is supported in a system only if both processors are operating at identical core and bus frequencies.

In this document, in order to distinguish between two Pentium processors in dual processing mode, one processor is the “Primary” processor and the other is the “Dual” processor.

The Pentium processor supports clock control. When the clock to the processor is stopped, power dissipation is virtually eliminated. The combination of these improvements makes the Pentium processor a good choice for energy-efficient designs.

The Pentium processor supports fractional bus operation. This allows the internal processor core to operate at high frequencies, while communicating with the external bus at lower frequencies.

The Pentium processor contains an on-chip Advanced Programmable Interrupt Controller (APIC). This APIC implementation supports multiprocessor interrupt management (with symmetric interrupt distribution across all processors), multiple I/O subsystem support, 8259A compatibility, and inter-processor interrupt support.

The architectural features introduced in this chapter are more fully described in the *Embedded Pentium® Processor Family Developer's Manual* (order number 273204).

## 1.2 Embedded Pentium® Processor with MMX™ Technology

The embedded Pentium processor with MMX technology is software and pin compatible with other members of the embedded Pentium processor family. It contains 4.5 million transistors and is manufactured on Intel's enhanced 0.35 micron CMOS process which allows voltage reduction technology for low power and high density. This enables the embedded Pentium processor with MMX technology to remain within the thermal envelope of the embedded Pentium processor while providing a significant performance increase.

The Pentium processor with MMX technology has several additional micro-architectural enhancements compared to the Pentium processor. The additions are described in the following sections.

### 1.2.1 Full Support for Intel's MMX™ Technology

MMX technology is based on the Single Instruction Multiple Data (SIMD) technique which enables increased performance on a wide variety of multimedia and communications applications. Fifty-seven new instructions and four new 64-bit data types are supported in the embedded Pentium processor with MMX technology. All existing operating system and application software are fully-compatible with the embedded Pentium processor with MMX technology.

### 1.2.2 16-Kbyte Code and Data Cache

On-chip, level-one (L1) data and code cache sizes have been doubled to 16 Kbytes each. These caches are 4-way set associative. Larger separate internal caches improve performance by reducing average memory access time and providing fast access to recently-used instructions and data. The instruction and data caches can be accessed simultaneously. The data cache supports two data references simultaneously. The data cache supports a write back policy (or alternatively, write-through, on a line-by-line basis) for memory updates. By default, the code cache is write-protected.

### 1.2.3 Improved Branch Prediction

Dynamic branch prediction uses the Branch Target Buffer (BTB) to boost performance by predicting the most likely set of instructions to be executed. The BTB has been improved to increase its accuracy. The embedded Pentium processor with MMX technology has four prefetch buffers that can hold up to four successive code streams.

### 1.2.4 Enhanced Pipeline

An additional pipeline stage has been added and the pipeline has been enhanced to improve performance. The integration of the MMX technology pipeline with the integer pipeline is very similar to that of the floating-point pipeline. Under some circumstances, two MMX instructions or one integer and one MMX instruction can be paired and issued in one clock cycle to increase throughput.

The enhanced pipeline is described in more detail in the *Embedded Pentium® Processor Family Developer's Manual* (order number 273204).

### 1.2.5 Deeper Write Buffers

A pool of four write buffers is now shared between the dual pipelines to improve memory write performance.

## 2.0 Packaging Information

### 2.1 Pinout

Figure 2. Pentium® Processor with MMX™ Technology PPGA Package  
Pinout - Top Side View

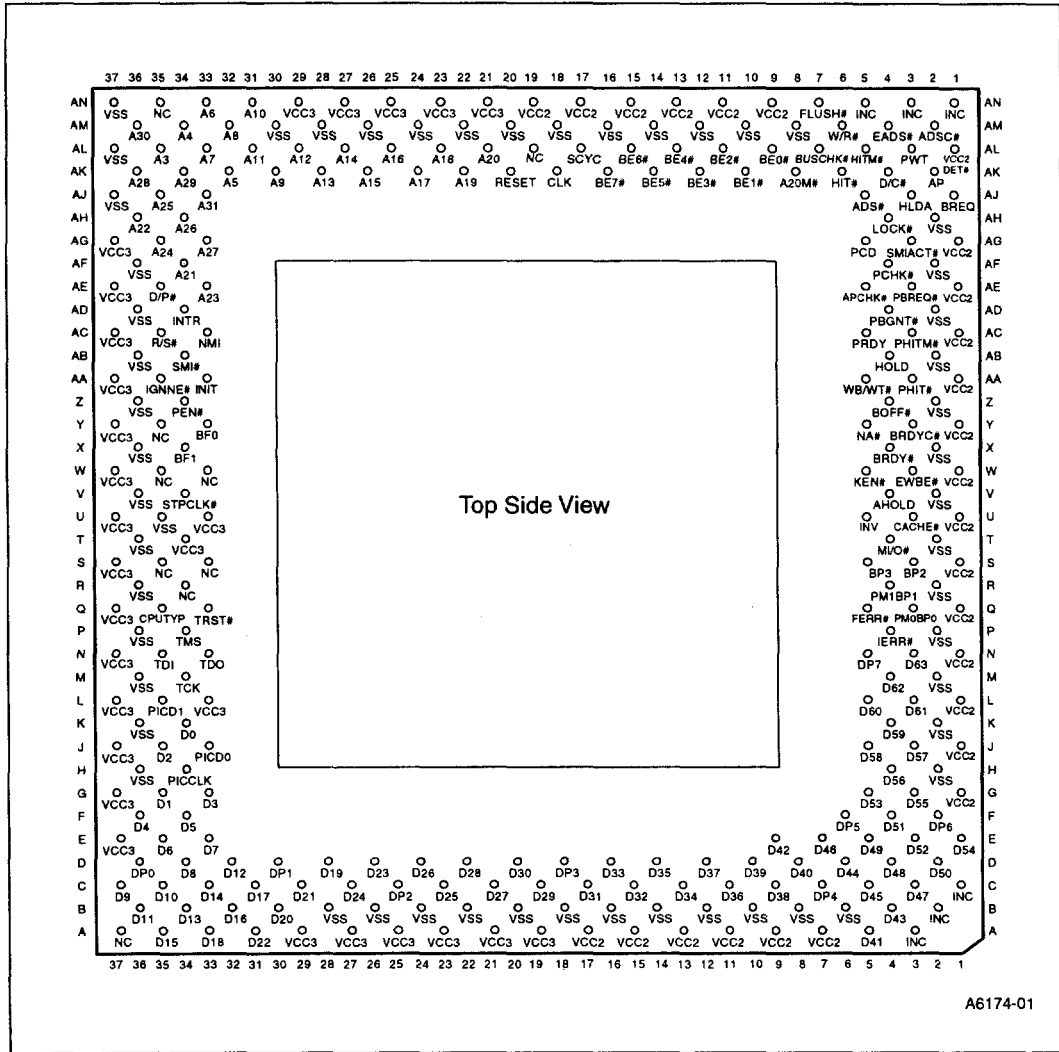
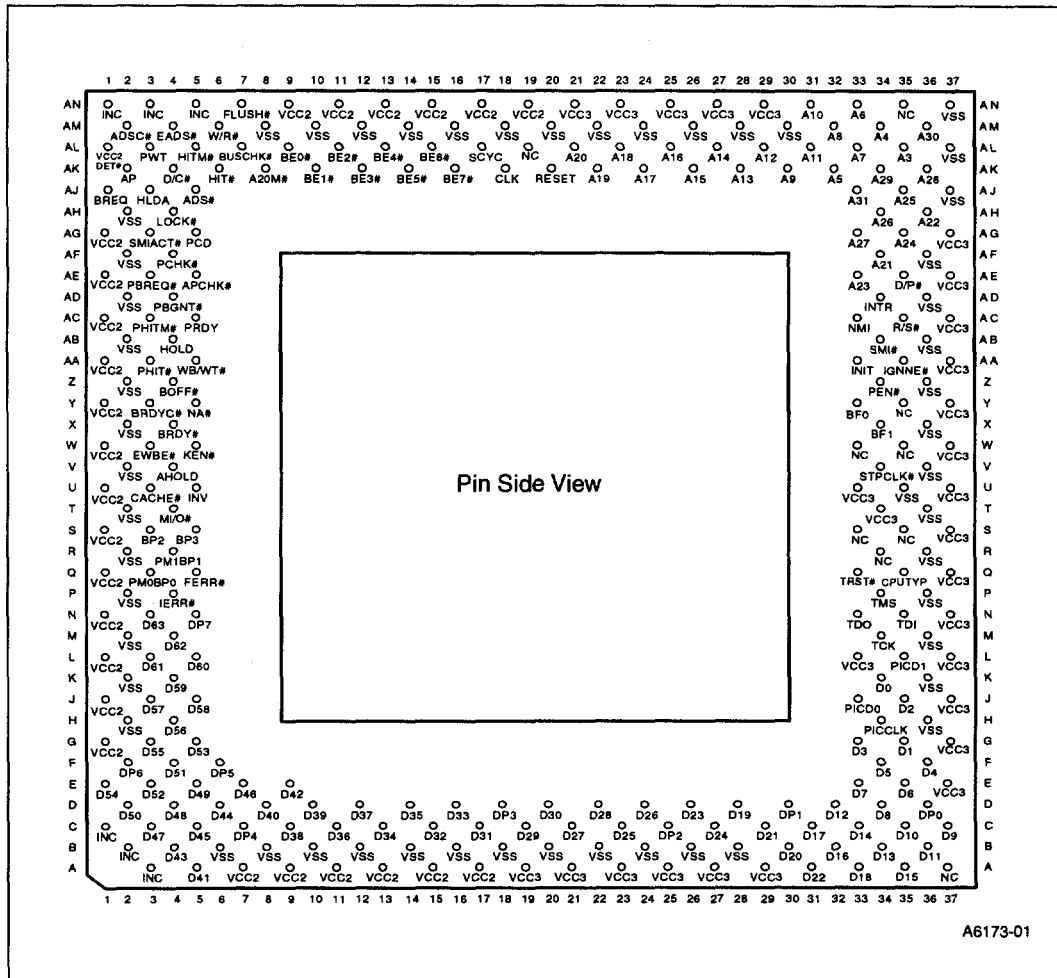



Figure 3. Pentium® Processor with MMX™ Technology PPGA Package Pinout - Bottom Side View



A6173-01



## 2.1.1 Pin Cross Reference

**Table 1. Pin Cross-Reference by Pin Name — Address and Data Pins**

Pin	Location	Pin	Location	Pin	Location	Pin	Location	Pin	Location
<b>Address</b>									
A3	AL35	A9	AK30	A15	AK26	A21	AF34	A27	AG33
A4	AM34	A10	AN31	A16	AL25	A22	AH36	A28	AK36
A5	AK32	A11	AL31	A17	AK24	A23	AE33	A29	AK34
A6	AN33	A12	AL29	A18	AL23	A24	AG35	A30	AM36
A7	AL33	A13	AK28	A19	AK22	A25	AJ35	A31	AJ33
A8	AM32	A14	AL27	A20	AL21	A26	AH34		
<b>Data</b>									
D0	K34	D13	B34	D26	D24	D39	D10	D52	E03
D1	G35	D14	C33	D27	C21	D40	D08	D53	G05
D2	J35	D15	A35	D28	D22	D41	A05	D54	E01
D3	G33	D16	B32	D29	C19	D42	E09	D55	G03
D4	F36	D17	C31	D30	D20	D43	B04	D56	H04
D5	F34	D18	A33	D31	C17	D44	D06	D57	J03
D6	E35	D19	D28	D32	C15	D45	C05	D58	J05
D7	E33	D20	B30	D33	D16	D46	E07	D59	K04
D8	D34	D21	C29	D34	C13	D47	C03	D60	L05
D9	C37	D22	A31	D35	D14	D48	D04	D61	L03
D10	C35	D23	D26	D36	C11	D49	E05	D62	M04
D11	B36	D24	C27	D37	D12	D50	D02	D63	N03
D12	D32	D25	C23	D38	C09	D51	F04		

**Table 2. Pin Cross-Reference by Pin Name — Control Pins**

Pin	Location	Pin	Location	Pin	Location	Pin	Location
<b>Control</b>							
A20M#	AK08	BREQ	AJ01	HIT#	AK06	PRDY	AC05
ADS#	AJ05	BUSCHK#	AL07	HITM#	AL05	PWT	AL03
ADSC#	AM02	CACHE#	U03	HLDA	AJ03	R/S#	AC35
AHOLD	V04	CPUTYP	Q35	HOLD	AB04	RESET	AK20
AP	AK02	D/C#	AK04	IERR#	P04	SCYC	AL17
APCHK#	AE05	D/P#	AE35	IGNNE#	AA35	SMI#	AB34
BE0#	AL09	DP0	D36	INIT	AA33	SMIACT#	AG03
BE1#	AK10	DP1	D30	INTR/LINT 0	AD34	TCK	M34
BE2#	AL11	DP2	C25	INV	U05	TDI	N35
BE3#	AK12	DP3	D18	KEN#	W05	TDO	N33
BE4#	AL13	DP4	C07	LOCK#	AH04	TMS	P34
BE5#	AK14	DP5	F06	M/IO#	T04	TRST#	Q33
BE6#	AL15	DP6	F02	NA#	Y05	VCC2DET#	AL01
BE7#	AK16	DP7	N05	NMI/LINT1	AC33	W/R#	AM06
BOFF#	Z04	EADS#	AM04	PCD	AG05	WB/WT#	AA05
BP2	S03	EWBE#	W03	PCHK#	AF04		
BP3	S05	FERR#	Q05	PEN#	Z34		
BRDY#	X04	FLUSH#	AN07	PM0/BP0	Q03		
BRDYC#	Y03	FRCMC# <sup>1</sup>	Y35	PM1/BP1	R04		
<b>APIC</b>							
PICCLK	H34 <sup>2</sup>	PICD0/[DP EN#]	J33	PICD1/[API CEN]	L35		
<b>Clock Control</b>							
CLK	AK18 <sup>2</sup>	[BF0]	Y33	[BF1]	X34	STPCLK#	V34
<b>Dual Processor Private Interface</b>							
PBGNT#	AD04	PBREQ#	AE03	PHIT#	AA03	PHITM#	AC03

**NOTES:**

1. The FRCMC# pin is not defined for the Pentium® processor with MMX™ technology. This pin should be left as a "NC" or tied to V<sub>CC3</sub> via an external pull-up resistor on the Pentium processor with MMX technology.
2. PICCLK and CLK are 3.3 V-tolerant-only on the Pentium processor with MMX technology. Please refer to the *Embedded Pentium® Processor Family Developer's Manual* (order number 273204) for the CLK and PICCLK signal quality specification.



**Table 3. Pin Cross-Reference by Pin Name — Power, Ground and No Connect Pins**

V <sub>CC2</sub>									
A17	A11	G01	N01	U01	AA01	AE01	AN09	AN13	AN17
A15	A09	J01	Q01	W01	AC01	AG01	AN11	AN15	AN19
A13	A07	L01	S01	Y01					
V <sub>CC3</sub>									
A19	A25	E37	L37	Q37	U33	Y37	AE37	AN27	AN21
A21	A27	G37	L33	S37	U37	AA37	AG37	AN25	
A23	A29	J37	N37	T34	W37	AC37	AN29	AN23	
V <sub>SS</sub>									
B06	B18	H02	P02	T36	X36	AD02	AJ37	AM14	AM24
B08	B20	H36	P36	U35	Z02	AD36	AL37	AM16	AM26
B10	B22	K02	R02	V02	Z36	AF02	AM08	AM18	AM28
B12	B24	K36	R36	V36	AB02	AF36	AM10	AM20	AM30
B14	B26	M02	T02	X02	AB36	AH02	AM12	AM22	AN37
B16	B28	M36							
NC									
A37	R34	S33	S35	W33	W35	AL19	AN35	Y35	
INC									
A03	B02	C01	AN01	AN03	AN05				

### 2.1.2 Design Notes

For reliable operation, always connect unused inputs to an appropriate signal level. Unused active low inputs should be connected to V<sub>CC3</sub>. Unused active high inputs should be connected to GND.

**Note:** No Connect (NC) pins *must* remain unconnected. Connection of NC or INC pins may result in component failure or incompatibility with future processor steppings.

### 2.1.3 Pin Quick Reference

This section gives a brief functional description of each of the pins. For a detailed description, see the Hardware Interface chapter in the *Embedded Pentium® Processor Family Developer's Manual* (order number 273204).

**Note:** All input pins must meet their AC/DC specifications to guarantee proper functional behavior.

The # symbol at the end of a signal name indicates that the active, or asserted state occurs when the signal is at a low voltage. When a # symbol is not present after the signal name, the signal is active, or asserted at the high voltage level. Square brackets around a signal name indicate that the signal is defined only at RESET.

The following pins become I/O pins when two Pentium processors with MMX technology are operating in a dual processing environment:

ADS#, CACHE#, HIT#, HITM#, HLDA#, LOCK#, M/IO#, D/C#, W/R#, SCYC, BE4#

Table 4. Quick Pin Reference (Sheet 1 of 7)

Symbol	Type	Name and Function
A20M#	I	When the <b>address bit 20 mask</b> pin is asserted, the processor emulates the address wraparound at 1 Mbyte which occurs on the 8086 by masking physical address bit 20 (A20) before performing a lookup to the internal caches or driving a memory cycle on the bus. The effect of A20M# is undefined in protected mode. A20M# must be asserted only when the processor is in real mode.  A20M# is internally masked by the processor when configured as a Dual processor.
A31–A3	I/O	As outputs, the <b>address</b> lines of the processor along with the byte enables define the physical area of memory or I/O accessed. The external system drives the inquire address to the processor on A31–A5.
ADS#	O	The <b>address strobe</b> indicates that a new valid bus cycle is currently being driven by the processor.
ADSC#	O	The <b>address strobe (copy)</b> is functionally identical to ADS#.
AHOLD	I	In response to the assertion of <b>address hold</b> , the Pentium® processor with MMX™ technology stops driving the address lines (A31–A3) and AP in the next clock. The rest of the bus remains active so data can be returned or driven for previously issued bus cycles.
AP	I/O	<b>Address parity</b> is driven by the processor with even parity information on all processor generated cycles in the same clock that the address is driven. Even parity must be driven back to the processor during inquire cycles on this pin in the same clock as EADS# to ensure that correct parity check status is indicated by the processor.
APCHK#	O	The <b>address parity check</b> status pin is asserted two clocks after EADS# is sampled active when the processor has detected a parity error on the address bus during inquire cycles. APCHK# remains active for one clock each time a parity error is detected (including during dual processing private snooping).
[APICEN] PICD1	I	<b>Advanced Programmable Interrupt Controller Enable</b> enables or disables the on-chip APIC interrupt controller. When sampled high at the falling edge of RESET, the APIC is enabled. APICEN shares a pin with the PICD1 signal.
BE7#–BE4# BE3#–BE0#	O I/O	The <b>byte enable</b> pins are used to determine which bytes must be written to external memory or which bytes were requested by the processor for the current cycle. The byte enables are driven in the same clock as the address lines (A31–A3).  Additionally, the lower 4-byte enables (BE3#–BE0#) are used on the Pentium processor with MMX technology as APIC ID inputs and are sampled at RESET. In dual processing mode, BE4# is used as an input during Flush cycles.
BF1–BF0	I	The <b>bus frequency</b> pins determine the bus-to-core frequency ratio. BF1–BF0 are sampled at RESET, and cannot be changed until another non-warm (1 ms) assertion of RESET. Additionally, BF1–BF0 must not change values while RESET is active. See Table 5 for Bus Frequency Selections.
BOFF#	I	The <b>backoff</b> input is used to abort all outstanding bus cycles that have not yet completed. In response to BOFF#, the processor floats all pins normally floated during bus hold in the next clock. The processor remains in bus hold until BOFF# is negated, at which time the processor restarts the aborted bus cycle(s) in their entirety.
BP3–BP2 PM1–PM0/ BP1–BP0	O	The <b>breakpoint</b> pins (BP3–BP0) correspond to the debug registers, DR3–DR0. These pins externally indicate a breakpoint match when the debug registers are programmed to test for breakpoint matches.  BP1 and BP0 are multiplexed with the <b>performance monitoring</b> pins (PM1 and PM0). The PB1 and PB0 bits in the Debug Mode Control Register determine if the pins are configured as breakpoint or performance monitoring pins. The pins come out of RESET configured for performance monitoring.

**Table 4. Quick Pin Reference (Sheet 2 of 7)**

Symbol	Type	Name and Function
BRDY#	I	The <b>burst ready</b> input indicates that the external system has presented valid data on the data pins in response to a read or that the external system has accepted the processor data in response to a write request. This signal is sampled in the T2, T12 and T2P bus states.
BRDYC#	I	The <b>burst ready (copy)</b> is functionally identical to BRDY#.
BREQ	O	The <b>bus request</b> output indicates to the external system that the processor has internally generated a bus request. This signal is always driven whether or not the processor is driving its bus.
BUSCHK#	I	<p>The <b>bus check</b> input allows the system to signal an unsuccessful completion of a bus cycle. If this pin is sampled active, the processor latches the address and control signals in the machine check registers. When the MCE bit in CR4 is set and the BUSCHK# pin is active, the processor vectors to the machine check exception.</p> <p>To assure that BUSCHK# is always recognized, STPCLK# must be deasserted any time BUSCHK# is asserted by the system, before the system allows another external bus cycle. When BUSCHK# is asserted by the system for a snoop cycle while STPCLK# remains asserted, usually (if MCE=1) the processor vectors to the exception after STPCLK# is deasserted. But if another snoop to the same line occurs during STPCLK# assertion, the processor can lose the BUSCHK# request.</p>
CACHE#	O	For processor-initiated cycles, the <b>cache</b> pin indicates internal cacheability of the cycle (if a read), and indicates a burst write back cycle (when a write). When this pin is driven inactive during a read cycle, the processor does not cache the returned data, regardless of the state of the KEN# pin. This pin is also used to determine the cycle length (number of transfers in the cycle).
CLK	I	<p>The <b>clock</b> input provides the fundamental timing for the processor. Its frequency is the operating frequency of the processor external bus, and requires TTL levels. All external timing parameters except TDI, TDO, TMS, TRST#, and PICD0–PICD1 are specified with respect to the rising edge of CLK.</p> <p>This pin is 3.3-V-tolerant-only on the Pentium processor with MMX technology. Please refer to the <i>Embedded Pentium® Processor Family Developer's Manual</i> (order number 273204) for the CLK and PICCLK signal quality specification.</p> <p>It is recommended that CLK begin toggling within 150 ms after V<sub>CC</sub> reaches its proper operating level. This recommendation is to ensure long-term reliability of the device.</p>
CPUTYP	I	<b>CPU type</b> distinguishes the Primary processor from the Dual processor. In a single processor environment, or when the processor is acting as the Primary processor in a dual processing system, CPUTYP should be strapped to V <sub>SS</sub> . The Dual processor should have CPUTYP strapped to V <sub>CC3</sub> .
D/C#	O	The <b>data/code</b> output is one of the primary bus cycle definition pins. It is driven valid in the same clock as the ADS# signal is asserted. D/C# distinguishes between data and code or special cycles.
D/P#	O	The <b>dual/primary</b> processor indication. The Primary processor drives this pin low when it is driving the bus, otherwise it drives this pin high. D/P# is always driven. D/P# can be sampled for the current cycle with ADS# (like a status pin). This pin is defined only on the Primary processor. Dual processing is supported in a system only if both processors are operating at identical core and bus frequencies. Within these restrictions, two processors of different steppings may operate together in a system.
D63–D0	I/O	These are the 64 <b>data lines</b> for the processor. Lines D7–D0 define the least significant byte of the data bus; lines D63–D56 define the most significant byte of the data bus. When the processor is driving the data lines, they are driven during the T2, T12, or T2P clocks for that cycle. During reads, the processor samples the data bus when BRDY# is returned.

Table 4. Quick Pin Reference (Sheet 3 of 7)

Symbol	Type	Name and Function
DP7–DP0	I/O	These are the <b>data parity</b> pins for the processor. There is one for each byte of the data bus. They are driven by the processor with even parity information on writes in the same clock as write data. Even parity information must be driven back to the processor on these pins in the same clock as the data to ensure that the correct parity check status is indicated by the processor. DP7 applies to D63–D56, DP0 applies to D7–D0.
[DPEN#] PICD0	I/O	<b>Dual processing enable</b> is an output of the Dual processor and an input of the Primary processor. The Dual processor drives DPEN# low to the Primary processor at RESET to indicate that the Primary processor should enable dual processor mode. DPEN# may be sampled by the system at the falling edge of RESET to determine if the dual-processor socket is occupied. DPEN# is multiplexed with PICD0.
EADS#	I	This signal indicates that a valid <b>external address</b> has been driven onto the processor address pins to be used for an inquire cycle.
EWBE#	I	The <b>external write buffer empty</b> input, when inactive (high), indicates that a write cycle is pending in the external system. When the processor generates a write, and EWBE# is sampled inactive, the processor holds off all subsequent writes to all E- or M-state lines in the data cache until all write cycles have completed, which is indicated by EWBE# being active.
FERR#	O	The <b>floating-point error</b> pin is driven active when an unmasked <b>floating-point</b> error occurs. FERR# is similar to the ERROR# pin on the Intel387™ math coprocessor. FERR# is included for compatibility with systems using DOS-type <b>floating-point</b> error reporting. FERR# is never driven active by the Dual processor.
FLUSH#	I	When asserted, the <b>cache flush</b> input forces the processor to write back all modified lines in the data cache and invalidate its internal caches. A Flush Acknowledge special cycle will be generated by the processor to indicate the completion of the write back and invalidation. When FLUSH# is sampled low when RESET transitions from high to low, three-state test mode is entered. When two Pentium processors with MMX technology are operating in dual processing mode and FLUSH# is asserted, the Dual processor performs a flush first (without a flush acknowledge cycle), then the Primary processor performs a flush followed by a flush acknowledge cycle. When the FLUSH# signal is asserted in dual processing mode, it must be deasserted at least one clock prior to BRDY# of the FLUSH Acknowledge cycle to avoid DP arbitration problems.
HIT#	O	The <b>hit</b> indication is driven to reflect the outcome of an inquire cycle. When an inquire cycle hits a valid line in the processor data or instruction cache, this pin is asserted two clocks after EADS# is sampled asserted. When the inquire cycle misses the processor cache, this pin is negated two clocks after EADS#. This pin changes its value only as a result of an inquire cycle and retains its value between the cycles.
HITM#	O	The <b>hit to a modified line</b> output is driven to reflect the outcome of an inquire cycle. It is asserted after inquire cycles which resulted in a hit to a modified line in the data cache. It is used to inhibit another bus master from accessing the data until the line is completely written back.
HLDA	O	The <b>bus hold acknowledge</b> pin goes active in response to a hold request driven to the processor on the HOLD pin. It indicates that the processor has floated most of the output pins and relinquished the bus to another local bus master. When leaving bus hold, HLDA will be driven inactive and the Pentium processor with MMX technology will resume driving the bus. If the processor has a bus cycle pending, it will be driven one clock cycle after HLDA is deasserted.



Table 4. Quick Pin Reference (Sheet 4 of 7)

Symbol	Type	Name and Function
HOLD	I	In response to the <b>bus hold request</b> , the processor floats most of its output and input/output pins and asserts HLDA after completing all outstanding bus cycles. The processor maintains its bus in this state until HOLD is deasserted. HOLD is not recognized during LOCK cycles. The processor recognizes HOLD during reset.
IERR#	O	The <b>internal error</b> pin is used to indicate internal parity errors. When a parity error occurs on a read from an internal array, the processor asserts the IERR# pin for one clock and then shuts down.
IGNNE#	I	This is the <b>ignore numeric error</b> input. This pin has no effect when the NE bit in CR0 is set to 1. When the CR0.NE bit is 0, and the IGNNE# pin is asserted, the processor ignores any pending unmasked numeric exception and continues executing floating-point instructions for the entire duration that this pin is asserted. When the CR0.NE bit is 0, IGNNE# is not asserted, a pending unmasked numeric exception exists (SW.ES = 1), and the floating-point instruction is one of FINIT, FCLEX, FSTENV, FSAVE, FSTSW, FSTCW, FENI, FDISI, or FSETPM, the processor executes the instruction in spite of the pending exception. When the CR0.NE bit is 0, IGNNE# is not asserted, a pending unmasked numeric exception exists (SW.ES = 1), and the floating-point instruction is one other than FINIT, FCLEX, FSTENV, FSAVE, FSTSW, FSTCW, FENI, FDISI, or FSETPM, the processor stops execution and waits for an external interrupt.  IGNNE# is internally masked when the processor is configured as a Dual processor.
INIT	I	The processor <b>initialization</b> input pin forces the processor to begin execution in a known state. The processor state after INIT is the same as the state after RESET except that the internal caches, write buffers, and floating-point registers retain the values they had prior to INIT. INIT may <i>not</i> be used instead of RESET after power-up.  When INIT is sampled high when RESET transitions from high to low, the processor performs a built-in self test prior to the start of program execution.
INTR/LINT0	I	An active <b>maskable interrupt</b> input indicates that an external interrupt has been generated. When the IF bit in the EFLAGS register is set, the processor generates two locked interrupt acknowledge bus cycles and vectors to an interrupt handler after the current instruction execution is completed. INTR must remain active until the first interrupt acknowledge cycle is generated to ensure that the interrupt is recognized.  When the local APIC is enabled, this pin becomes LINT0.
INV	I	The <b>invalidation</b> input determines the final cache line state (S or I) in case of an inquire cycle hit. It is sampled together with the address for the inquire cycle in the clock EADS# is sampled active.
KEN#	I	The <b>cache enable</b> pin is used to determine whether the current cycle is cacheable or not and is consequently used to determine cycle length. When the processor generates a cycle that can be cached (CACHE# asserted) and KEN# is active, the cycle is transformed into a burst line fill cycle.
LINT0/INTR	I	When the APIC is enabled, this pin is <b>local interrupt 0</b> . When the APIC is disabled, this pin is INTR.
LINT1/NMI	I	When the APIC is enabled, this pin is <b>local interrupt 1</b> . When the APIC is disabled, this pin is NMI.
LOCK#	O	The <b>bus lock</b> pin indicates that the current bus cycle is locked. The Pentium processor with MMX technology does not allow a bus hold when LOCK# is asserted (but AHOLD and BOFF# are allowed). LOCK# goes active in the first clock of the first locked bus cycle and goes inactive after the BRDY# is returned for the last locked bus cycle. LOCK# is guaranteed to be deasserted for at least one clock between back-to-back locked cycles.



Table 4. Quick Pin Reference (Sheet 5 of 7)

Symbol	Type	Name and Function
M/IO#	O	The <b>memory/input-output</b> is one of the primary bus cycle definition pins. It is driven valid in the same clock as the ADS# signal is asserted. M/IO# distinguishes between memory and I/O cycles.
NA#	I	An active <b>next address</b> input indicates that the external memory system is ready to accept a new bus cycle although all data transfers for the current cycle have not yet completed. The processor issues ADS# for a pending cycle two clocks after NA# is asserted. The processor supports up to two outstanding bus cycles.
NMI/LINT1	I	The <b>non-maskable interrupt</b> request signal indicates that an external non-maskable interrupt has been generated. When the local APIC is enabled, this pin becomes LINT1.
PBGNT#	I/O	<b>Private bus grant</b> is the grant line that is used when two Pentium processors with MMX technology are configured in dual processing mode, in order to perform private bus arbitration. PBGNT# should be left unconnected if only one Pentium processor with MMX technology exists in a system.
PBREQ#	I/O	<b>Private bus request</b> is the request line that is used when two Pentium processors with MMX technology are configured in dual processing mode, in order to perform private bus arbitration. PBREQ# should be left unconnected when only one processor exists in a system.
PCD	O	The <b>page cache disable</b> pin reflects the state of the PCD bit in CR3, the Page Directory Entry, or the Page Table Entry. PCD provides an external cacheability indication on a page by page basis.
PCHK#	O	The <b>parity check</b> output indicates the result of a parity check on a data read. It is driven with parity status two clocks after BRDY# is returned. PCHK# remains low one clock for each clock in which a parity error was detected. Parity is checked only for the bytes on which valid data is returned. When two Pentium processors with MMX technology are operating in dual processing mode, PCHK# may be driven two or three clocks after BRDY# is returned.
PEN#	I	The <b>parity enable</b> input (along with CR4.MCE) determines whether a machine check exception will be taken as a result of a data parity error on a read cycle. When this pin is sampled active in the clock a data parity error is detected, the processor latches the address and control signals of the cycle with the parity error in the machine check registers. When PEN# is sampled active and the machine check enable bit in CR4 is set to "1", the processor vectors to the machine check exception before the beginning of the next instruction.
PHIT#	I/O	<b>Private hit</b> is a hit indication used when two Pentium processors with MMX technology are configured in dual processing mode, in order to maintain local cache coherency. PHIT# should be left unconnected when only one processor exists in a system.
PHITM#	I/O	<b>Private modified hit</b> is a hit on a modified cache line indication used when two Pentium processors with MMX technology are configured in dual processing mode, in order to maintain local cache coherency. PHITM# should be left unconnected if only one processor exists in a system.
PICCLK	I	The APIC interrupt controller serial data bus clock is driven into the <b>programmable interrupt controller clock</b> input of the processor. This pin is 3.3-V-tolerant-only on the Pentium processor with MMX technology. Please refer to the <i>Embedded Pentium® Processor Family Developer's Manual</i> (order number 273204) for the CLK and PICCLK signal quality specification.
PICD0[DPEN#]– PICD1[APICEN]	I/O	<b>Programmable interrupt controller data lines 0–1</b> of the Pentium processor with MMX technology comprise the data portion of the APIC 3-wire bus. They are open-drain outputs that require external pull-up resistors. These signals are multiplexed with DPEN# and APICEN respectively.



**Table 4. Quick Pin Reference (Sheet 6 of 7)**

Symbol	Type	Name and Function
PM1/BP1– PM0/BP0	O	These pins function as part of the performance monitoring feature. The breakpoint 1–0 pins are multiplexed with the <b>performance monitoring 1–0</b> pins. The PB1 and PB0 bits in the Debug Mode Control Register determine if the pins are configured as breakpoint or performance monitoring pins. The pins come out of RESET configured for performance monitoring.
PRDY	O	The <b>probe ready</b> output pin is provided for use with the Intel debug port. Please refer to the <i>Embedded Pentium® Processor Family Developer's Manual</i> (order number 273204) for more details.
PWT	O	The <b>page write through</b> pin reflects the state of the PWT bit in CR3, the page directory entry, or the page table entry. The PWT pin is used to provide an external write back indication on a page-by-page basis.
R/S#	I	The <b>run/stop</b> input is provided for use with the Intel debug port. Please refer to the <i>Embedded Pentium® Processor Family Developer's Manual</i> (order number 273204) for more details.
RESET	I	<b>RESET</b> forces the processor to begin execution at a known state. All the processor internal caches will be invalidated upon the RESET. Modified lines in the data cache are not written back. FLUSH# and INIT are sampled when RESET transitions from high to low to determine if three-state test mode or checker mode will be entered, or if Built-In Self-Test (BIST) will be run.
SCYC	O	The <b>split cycle</b> output is asserted during misaligned LOCKed transfers to indicate that more than two cycles will be locked together. This signal is defined for locked cycles only. It is undefined for cycles which are not locked.
SMI#	I	The <b>system management interrupt</b> causes a system management interrupt request to be latched internally. When the latched SMI# is recognized on an instruction boundary, the processor enters System Management Mode.
SMACT#	O	An active <b>system management interrupt active</b> output indicates that the processor is operating in System Management Mode.
STPCLK#	I	Assertion of the <b>stop clock</b> input signifies a request to stop the internal clock of the processor, thereby causing the core to consume less power. When the processor recognizes STPCLK#, the processor stops execution on the next instruction boundary, unless superseded by a higher priority interrupt, and generates a stop grant acknowledge cycle. When STPCLK# is asserted, the processor still responds to interprocessor and external snoop requests.
TCK	I	The <b>testability clock</b> input provides the clocking function for the processor boundary scan in accordance with the IEEE Boundary Scan interface (Standard 1149.1). It is used to clock state information and data into and out of the processor during boundary scan.
TDI	I	The <b>test data input</b> is a serial input for the test logic. TAP instructions and data are shifted into the processor on the TDI pin on the rising edge of TCK when the TAP controller is in an appropriate state.
TDO	O	The <b>test data output</b> is a serial output of the test logic. TAP instructions and data are shifted out of the processor on the TDO pin on TCK's falling edge when the TAP controller is in an appropriate state.
TMS	I	The value of the <b>test mode select</b> input signal sampled at the rising edge of TCK controls the sequence of TAP controller state changes.
TRST#	I	When asserted, the <b>test reset</b> input allows the TAP controller to be asynchronously initialized.
VCC2	I	The Pentium processor with MMX technology has 25 2.8 V <b>power</b> inputs.
VCC3	I	The Pentium processor with MMX technology has 28 3.3 V <b>power</b> inputs.
VCC2DET#	O	<b>V<sub>CC2</sub> detect</b> is used in flexible motherboard implementations to configure the voltage output set-point appropriately for the V <sub>CC2</sub> inputs of the processor.

**Table 4. Quick Pin Reference (Sheet 7 of 7)**

Symbol	Type	Name and Function
VSS	I	The Pentium processor with MMX technology has 53 <b>ground</b> inputs.
W/R#	O	<b>Write/read</b> is one of the primary bus cycle definition pins. It is driven valid in the same clock as the ADS# signal is asserted. W/R# distinguishes between write and read cycles.
WB/WT#	I	The <b>write back/write through</b> input allows a data cache line to be defined as write back or write through on a line-by-line basis. As a result, it determines whether a cache line is initially in the S or E state in the data cache.

Core and bus frequencies can be set according to Table 5. Each Pentium processor with MMX technology is specified to operate within a single bus-to-core ratio and a specific minimum-to-maximum bus-frequency range (corresponding to a minimum-to-maximum core-frequency range). Operation in other bus-to-core ratios or outside the specified operating frequency range is not supported or advocated. For example, the 166 MHz Pentium processor with MMX technology does not operate beyond the 66 MHz bus frequency and only supports the 2/5 bus-to-core ratio; it does not support the 1/3, 1/2, or 2/3 bus-to-core ratios.

**Table 5. Bus Frequency Selections**

BF1	BF0	Bus/Core Ratio	Max Bus/Core Frequency (MHz)	Min Bus/Core Frequency (MHz)
0	1	1/3	66/200	33/100
0	0	2/5	N/A <sup>(2)</sup>	N/A <sup>(2)</sup>
1	0	1/2 <sup>(1,2)</sup>	N/A <sup>(2)</sup>	N/A <sup>(2)</sup>
1	1	2/7	66/233	33/117

**NOTES:**

1. This is the default bus to core ratio for the Pentium® processor with MMX™ technology. If the BF pins are left floating, the processor will be configured for the 1/2 bus to core frequency ratio.
2. Currently, there are no embedded products that support these bus fractions.

## 2.1.4 Pin Reference Tables

**Table 6. Output Pins**

Name	Active Level	When Floated
ADS# <sup>(1)</sup>	Low	Bus Hold, BOFF#
ADSC#	Low	Bus Hold, BOFF#
APCHK#	Low	
BE7#–BE4#	Low	Bus Hold, BOFF#
BREQ	High	
CACHE# <sup>(1)</sup>	Low	Bus Hold, BOFF#
D/P# <sup>(2)</sup>	N/A	
FERR# <sup>(2)</sup>	Low	
HIT# <sup>(1)</sup>	Low	
HITM# <sup>(1, 3)</sup>	Low	
HLDA <sup>(1)</sup>	High	
IERR#	Low	
LOCK# <sup>(1)</sup>	Low	Bus Hold, BOFF#
M/IO# <sup>(1)</sup> , D/C# <sup>(1)</sup> , W/R# <sup>(1)</sup>	N/A	Bus Hold, BOFF#
PCHK#	Low	
BP3–BP2, PM1/BP1, PM0/BP0	High	
PRDY	High	
PWT, PCD	High	Bus Hold, BOFF#
SCYC <sup>(1)</sup>	High	Bus Hold, BOFF#
SMIACK#	Low	
TDO	N/A	All states except Shift-DR and Shift-IR
VCC2DET#	Low	

**NOTES:**

All output and input/output pins are floated during three-state test mode (except IERR#).

1. These are I/O signals when two Pentium® processors with MMX™ technology are operating in dual processing mode.

2. These signals are undefined when the processor is configured as a Dual processor.

3. M# pin has an internal pull-up resistor.

Table 7. Input Pins

Name	Active Level	Synchronous/ Asynchronous	Internal Resistor	Qualified
A20M#†	Low	Asynchronous		
AHOLD	High	Synchronous		
APICEN	High	Synchronous/RESET	Pull-up	
BF0	N/A	Synchronous/RESET	Pull-down	
BF1	N/A	Synchronous/RESET	Pull-up	
BOFF#	Low	Synchronous		
BRDY#	Low	Synchronous	Pull-up	Bus State T2, T12, T2P
BRDYC#	Low	Synchronous	Pull-up	Bus State T2, T12, T2P
BUSCHK#	Low	Synchronous	Pull-up	BRDY#
CLK	N/A			
CPUTYP	High	Synchronous/RESET	Pull-down	
EADS#	Low	Synchronous		
EWBE#	Low	Synchronous		BRDY#
FLUSH#	Low	Asynchronous		
HOLD	High	Synchronous		
IGNNE#†	Low	Asynchronous		
INIT	High	Asynchronous		
INTR	High	Asynchronous		
INV	High	Synchronous		EADS#
LINT1–LINT0	High	Asynchronous		APICEN at RESET
KEN#	Low	Synchronous		First BRDY#/NA#
NA#	Low	Synchronous		Bus State T2, TD, T2P
NMI	High	Asynchronous		
PEN#	Low	Synchronous		BRDY#
PICCLK	High	Asynchronous	Pull-up	
R/S#	N/A	Asynchronous	Pull-up	
RESET	High	Asynchronous		
SMI#	Low	Asynchronous	Pull-up	
STPCLK#	Low	Asynchronous	Pull-up	
TCK	N/A		Pull-up	
TDI	N/A	Synchronous/TCK	Pull-up	TCK
TMS	N/A	Synchronous/TCK	Pull-up	TCK
TRST#	Low	Asynchronous	Pull-up	
WB/WT#	N/A	Synchronous		First BRDY#/NA#

† Undefined when the processor is configured as a Dual processor.



**Table 8. Input/Output Pins**

Name <sup>(1)</sup>	Active Level	When Floated	Qualified (when an input)	Internal Resistor
A31–A3	N/A	Address Hold, Bus Hold, BOFF#	EADS#	
AP	N/A	Address Hold, Bus Hold, BOFF#	EADS#	
BE3#–BE0#	Low	Address Hold, Bus Hold, BOFF#	RESET	Pull-down <sup>(2)</sup>
D63–D0	N/A	Bus Hold, BOFF#	BRDY#	
DP7–DP0	N/A	Bus Hold, BOFF#	BRDY#	
DPEN#	low		RESET	Pull-up
PICD0	N/A			Pull-up
PICD1	N/A			Pull-down

**NOTES:**

1. All output and input/output pins are floated during three-state test mode (except TDO, IERR# and TDO).
2. BE3#–BE0# have Pull-downs during RESET only.

**Table 9. Inter-processor Input/Output Pins**

Name	Active Level	Internal Resistor
PHIT#	Low	Pull-up
PHITM#	Low	Pull-up
PBGNT#	Low	Pull-up
PBREQ#	Low	Pull-up

**NOTE:** For proper inter-processor operation, the system cannot load these signals.

## 2.1.5 Pin Grouping According to Function

Table 10 organizes the pins with respect to their function.

**Table 10. Pin Functional Grouping**

Function	Pins
Clock	CLK
Initialization	RESET, INIT, BF1–BF0
Address Bus	A31–A3, BE7#–BE0#
Address Mask	A20M#
Data Bus	D63–D0
Address Parity	AP, APCHK#
APIC Support	PICCLK, PICD1–PICD0
Data Parity	DP7–DP0, PCHK#, PEN#
Internal Parity Error	IERR#
System Error	BUSCHK#
Bus Cycle Definition	M/IO#, D/C#, W/R#, CACHE#, SCYC, LOCK#
Bus Control	ADS#, ADSC#, BRDY#, BRDYC#, NA#
Page Cacheability	PCD, PWT
Cache Control	KEN#, WB/WT#
Cache Snooping/Consistency	AHOLD, EADS#, HIT#, HITM#, INV
Cache Flush	FLUSH#
Write Ordering	EWBE#
Bus Arbitration	BOFF#, BREQ, HOLD, HLDA
Dual Processing Private Bus Control	PBGNT#, PBREQ#, PHIT#, PHITM#
Interrupts	INTR, NMI
Floating-Point Error Reporting	FERR#, IGNNE#
System Management Mode	SMI#, SMIACT#
TAP Port	TCK, TMS, TDI, TDO, TRST#
Breakpoint/Performance Monitoring	PM0/BP0, PM1/BP1, BP3–BP2
Power Management	STPCLK#
Miscellaneous Dual Processing	CPUTYP, D/P#
Debugging	R/S#, PRDY
Voltage Detection	VCC2DET#

## 2.2 Mechanical Specifications

Package summary information is provided in Table 11. The mechanical specifications for the Pentium processor with MMX technology are provided in Table 12 and Figure 4.

**Table 11. PPGA Package Information**

Package Type	Total Pins	Pin Array	Package Size
Plastic Staggered Pin Grid Array (PPGA)	296	37 x 37	1.95" x 1.95" 4.95 cm x 4.95 cm

**Figure 4. PPGA Package Dimensions**

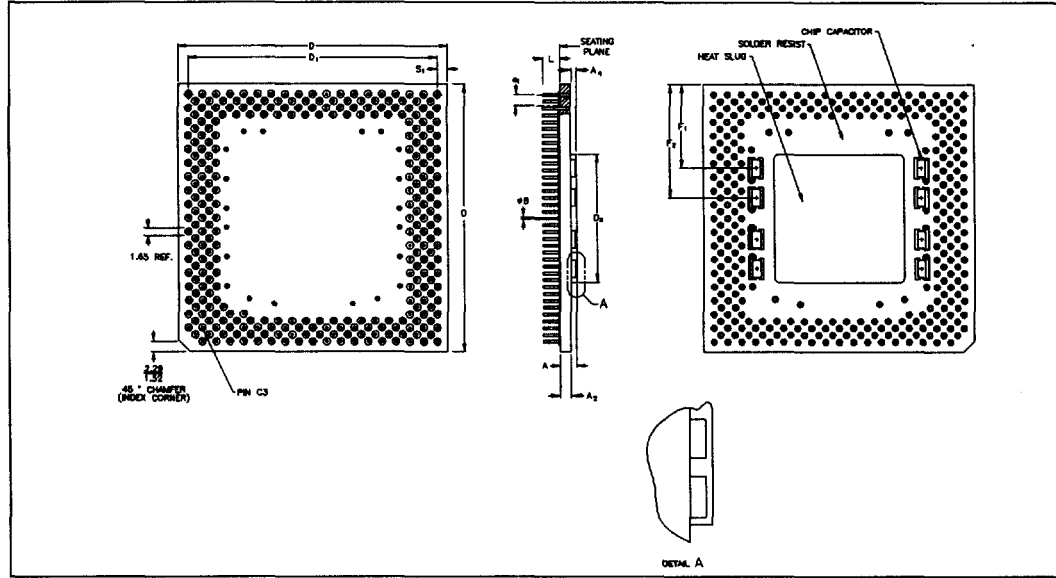

**Table 12. PPGA Package Dimensions**

Symbol	Millimeters			Inches		
	Min	Max	Notes	Min	Max	Notes
A	2.72	3.33		0.107	0.131	
A <sub>1</sub>	1.83	2.23		0.072	0.088	
A <sub>2</sub>	1.00			0.039		
B	0.40	0.51		0.016	0.020	
D	49.43	49.63		1.946	1.954	
D <sub>1</sub>	45.59	45.85		1.795	1.805	
D <sub>2</sub>	23.44	23.95		0.923	0.943	
e <sub>1</sub>	2.29	2.79		0.090	0.110	
F <sub>1</sub>	17.56			0.692		
F <sub>2</sub>	23.04			0.907		
L	3.05	3.30		0.120	0.130	
N	296		Lead Count	296		Lead Count
S <sub>1</sub>	1.52	2.54		0.060	0.100	



## 2.3 Thermal Specifications

The Pentium processor with MMX technology is specified for proper operation when case temperature,  $T_{CASE}$ , ( $T_C$ ) is within the range of 0° C to 70° C.

The power dissipation specification in Table 13 is provided for designing thermal solutions for operation at a sustained maximum level. This is the worst-case power the device would dissipate in a system for a sustained period of time. This number is provided to assist in the design of a thermal solution for the device.

**Table 13. Power Dissipation Requirements for Thermal Design**

Measured at  $V_{CC2}=2.8$  V and  $V_{CC3}=3.3$  V

Parameter	Typical (1)	Max (2)	Unit	Notes
Active Power	7.9 <sup>(3)</sup>	17.0 <sup>(4)</sup>	Watts	233 MHz
	7.3 <sup>(3)</sup>	15.7 <sup>(4)</sup>	Watts	200 MHz
Stop Grant/Auto Halt Powerdown Power		2.61	Watts	233 MHz, Note 5
		2.41	Watts	200 MHz, Note 5
Stop Clock Power	0.03	< 0.3	Watts	All frequencies, Note 6

### NOTES:

1. This is the typical power dissipation in a system. This value is expected to be the average value that will be measured in a system using a typical device at  $V_{CC2} = 2.8$  V running typical applications. This value is highly dependent upon the specific system configuration. Typical power specifications are not tested.
2. Systems must be designed to thermally dissipate the maximum active power dissipation. It is determined using worst case instruction mix with  $V_{CC2} = 2.8$  V and  $V_{CC3} = 3.3$  V and also takes into account the thermal time constants of the package.
3. Active Power (typ) is the average power measured in a system using a typical device running typical applications under normal operating conditions at nominal  $V_{CC}$  and room temperature.
4. Active Power (max) is the maximum power dissipation under normal operating conditions at nominal  $V_{CC2}$ , worst-case temperature, while executing the worst case power instruction mix. Active power (max) is equivalent to Thermal Design Power (max).
5. Stop Grant/Auto Halt Power Down Power Dissipation is determined by asserting the STPCLK# pin or executing the HALT instruction.
6. Stop Clock Power Dissipation is determined by asserting the STPCLK# pin and then removing the external CLK input.

## 2.4 Measuring Thermal Values

To verify that the proper  $T_C$  is maintained, it should be measured at the center of the package top surface (opposite of the pins). The measurement is made in the same way with or without a heatsink attached. When a heatsink is attached, a hole (smaller than 0.150" diameter) should be drilled through the heatsink to allow probing the center of the package. See Figure 5 for an illustration of how to measure  $T_C$ .

To minimize the measurement errors, use the following approach:

- Use 36-gauge or finer diameter K, T, or J type thermocouples. The laboratory testing was done using a thermocouple made by Omega (part number 5TC-TTK-36-36).
- Attach the thermocouple bead or junction to the center of the package top surface using high thermal conductivity cements. The laboratory testing was done by using Omega Bond\* (part number OB-100).
- Attach the thermocouple at a 90-degree angle as shown in Figure 5.

- The hole size should be smaller than 0.150" in diameter.
- Make sure there is no contact between thermocouple cement and heatsink base. The contact will affect the thermocouple reading.

### 2.4.1 Thermal Equations

For the Pentium processor with MMX technology, an ambient temperature,  $T_A$  (air temperature around the processor), is not specified directly. The only restriction is that  $T_C$  is met. To calculate  $T_A$  values, use the following equations:

$$T_A = T_C - (P * \theta_{CA})$$

$$\theta_{CA} = \theta_{JA} - \theta_{JC}$$

Where:

$T_A$  and  $T_C$  = Ambient and case temperature (°C)

$\theta_{CA}$  = Case-to-ambient thermal resistance (°C/Watt)

$\theta_{JA}$  = Junction-to-ambient thermal resistance (°C/Watt)

$\theta_{JC}$  = Junction-to-case thermal resistance (°C/Watt)

$P$  = Maximum power consumption (Watt)

Table 14 lists the  $\theta_{JC}$  and  $\theta_{CA}$  values for the Pentium processor with MMX technology and a passive heatsink.  $\theta_{JC}$  is thermal resistance from die to package case.  $\theta_{JC}$  values shown in these tables are typical values. The actual  $\theta_{JC}$  values depend on actual thermal conductivity and process of die attach.  $\theta_{CA}$  is thermal resistance from package case to the ambient.  $\theta_{CA}$  values shown in these tables are typical values. The actual  $\theta_{CA}$  values depend on the heatsink design, the interface between the heatsink and the package, the air flow in the system, and thermal interactions between the processor and the surrounding components through the printed-circuit board and the ambient air. Figure 6 is a graph of the data from Table 14.

Thermal data collection parameters:

- Heatsinks are omni-directional pin aluminum alloy
- Features were based on standard extrusion practices for a given height
- Pin size ranged from 50 to 129 mils
- Pin spacing ranged from 93 to 175 mils
- Base thickness ranged from 79 to 200 mils
- Heatsink attach was 0.005" of thermal grease
- Attach thickness of 0.002" will improve performance approximately 0.3° C/Watt

Figure 5. Technique for Measuring  $T_C$  on PPGA Packages

Table 14. Thermal Resistance for PPGA Packages

Heat Sink Height (inches)	$\theta_{JC}$ (°C/Watt)	$\theta_{CA}$ (°C/Watt) vs. Laminar Airflow (linear ft/min)					
		0	100	200	400	600	800
0.25	0.4	8.9	7.8	6.4	4.3	3.4	2.8
0.35	0.4	8.6	7.3	5.8	3.8	3.1	2.6
0.45	0.4	8.2	6.8	5.1	3.4	2.7	2.3
0.55	0.4	7.9	6.3	4.5	3.0	2.4	2.1
0.65	0.4	7.5	5.8	4.1	2.8	2.2	1.9
0.80	0.4	6.8	5.1	3.7	2.6	2.0	1.8
1.00	0.4	6.1	4.5	3.4	2.4	1.9	1.6
1.20	0.4	5.7	4.1	3.1	2.2	1.8	1.6
1.40	0.4	5.2	3.7	2.8	2.0	1.7	1.5
None	1.2	12.9	12.2	11.2	7.7	6.3	5.4

Figure 6. Thermal Resistance vs. Heatsink Height, PPGA Packages

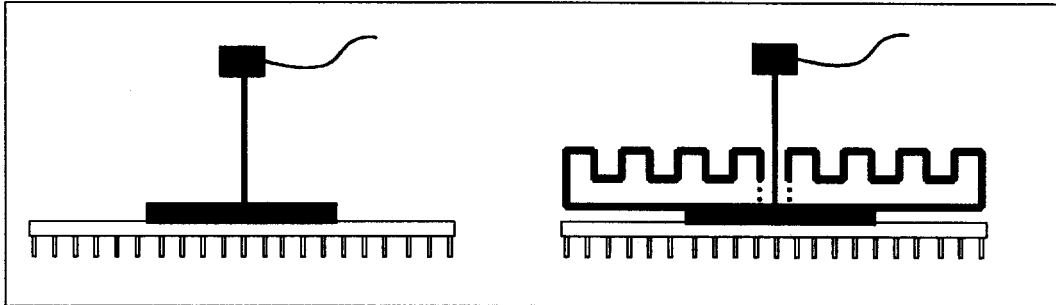
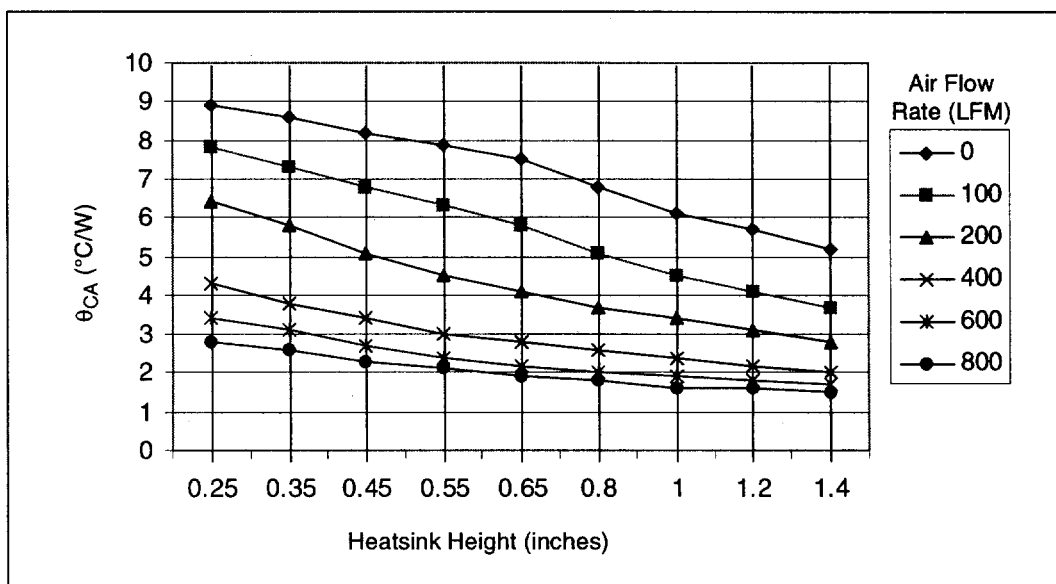

## 3.0 Electrical Specifications

---

This section describes the electrical differences between the Pentium processor with MMX technology and the Pentium processor, and the AC and DC specifications of the Pentium processor with MMX technology.

### 3.1 Electrical Characteristics

When creating a Pentium processor with MMX technology design based on an existing Pentium processor design, there are a number of electrical differences that require attention. The following sections highlight key electrical issues pertaining to the Pentium processor with MMX technology power supplies, connection specifications and buffer models.

Note that it is possible to design a single motherboard that supports more than one member of the Pentium processor family. Refer to *Pentium® Processor Flexible Motherboard Design Guidelines* (order number 243187) for more information and specific implementation examples.

#### 3.1.1 Power Supplies

The main electrical difference between the Pentium processor with MMX technology and the Pentium processor is the operating voltage. The Pentium processor with MMX technology requires two separate voltage inputs,  $V_{CC2}$  and  $V_{CC3}$ . The  $V_{CC2}$  pins supply power to the Pentium processor with MMX technology core, while the  $V_{CC3}$  pins supply power to the processor I/O pins.

The Pentium processor, on the other hand, requires a single voltage supply for all  $V_{CC}$  pins. This single supply powers both the core and I/O pins of the Pentium processor.

By connecting all the  $V_{CC2}$  pins together and all the  $V_{CC3}$  pins together on separate power islands, Pentium processor designs can easily be converted to support the Pentium processor with MMX technology. In order to maintain compatibility with Pentium processor-based platforms, the Pentium processor with MMX technology supports the standard 3.3-V specification on its  $V_{CC3}$  pins.

#### 3.1.2 Power Supply Sequencing

There is no specific power sequence required for powering up or powering down the separate  $V_{CC2}$  and  $V_{CC3}$  supplies of the Pentium processor with MMX technology. It is recommended that the  $V_{CC2}$  and  $V_{CC3}$  supplies be turned on or off within one second of each other.

#### 3.1.3 Connection Specifications

Connection specifications for the power and ground inputs, 3.3-V inputs and outputs, and the NC/INC and unused inputs are discussed in the following sections.

### 3.1.3.1 Power and Ground

For clean on-chip power distribution, the embedded Pentium processor with MMX technology has 28  $V_{CC3}$  (I/O power), 25  $V_{CC2}$  (core power) and 53  $V_{SS}$  (ground) inputs. Power and ground connections must be made to all external  $V_{CC}$  and  $V_{SS}$  pins of the Pentium processor with MMX technology. On the circuit board, all  $V_{CC3}$  pins must be connected to a 3.3-V  $V_{CC}$  plane. All  $V_{CC3}$  pins must be connected to a 2.8-V  $V_{CC}$  plane. All  $V_{SS}$  pins must be connected to a  $V_{SS}$  plane.

### 3.1.3.2 $V_{CC2}$ and $V_{CC3}$ Measurement Specification

The values of  $V_{CC2}$  and  $V_{CC3}$  should be measured at the bottom side of the processor pins using an oscilloscope with a 3 dB bandwidth of at least 20 MHz (100 MS/s digital sampling rate). There should be a short isolation ground lead attached to a processor pin on the bottom side of the board.

The measurement should be taken at the following  $V_{CC}/V_{SS}$  pairs: AN13/AM10, AN21/AM18, AN29/AM26, AC37/Z36, U37/R36, L37/H36, A25/B28, A17/B20, A7/B10, G1/K2, S1/V2, AC1/Z2. One-half of these pins are  $V_{CC2}$  while the others are  $V_{CC3}$ ; the operating ranges for the  $V_{CC2}$  and  $V_{CC3}$  pins are specified at different voltages. See Table 16 for the specification.

The display should show continuous sampling of the voltage line, at 20 mV/div, and 500 ns/div with the trigger point set to the center point of the range. Slowly move the trigger to the high and low ends of the specification, and verify that excursions beyond these limits are not observed. There are no allowances for crossing the high and low limits of the voltage specification. For more information on measurement techniques, see *Voltage Guidelines for Pentium® Processors with MMX™ Technology* (order number 243186).

### 3.1.3.3 Decoupling Recommendations

Liberal decoupling capacitance should be placed near the Pentium processor with MMX technology. The Pentium processor with MMX technology, when driving its large address and data buses at high frequencies, can cause transient power surges, particularly when driving large capacitive loads.

Low inductance capacitors and interconnects are recommended for best high-frequency electrical performance. Inductance can be reduced by shortening circuit board traces between the Pentium processor with MMX technology and decoupling capacitors as much as possible. These capacitors should be evenly distributed around each component on the power plane. Capacitor values should be chosen to ensure they eliminate both low and high frequency noise components.

For the Pentium processor with MMX technology, the power consumption can transition from a low level of power to a much higher level (or high to low power) very rapidly. A typical example would be entering or exiting the Stop Grant State. Another example would be executing a HALT instruction, causing the Pentium processor with MMX technology to enter the AutoHALT Power Down State, or transitioning from HALT to the Normal State. All of these examples may cause abrupt changes in the power being consumed by the Pentium processor with MMX technology. Note that the AutoHALT Power Down feature is always enabled even when other power management features are not implemented.

Bulk storage capacitors with a low Effective Series Resistance (ESR) in the 10- $\Omega$  to 100- $\Omega$  range are required to maintain a regulated supply voltage during the interval between the time the current load changes and the point that the regulated power supply output can react to the change in load. In order to reduce the ESR, it may be necessary to place several bulk storage capacitors in parallel.

These capacitors should be placed near the Pentium processor with MMX technology on both the  $V_{CC2}$  and  $V_{CC3}$  plane to ensure that the supply voltage stays within specified limits during changes in the supply current during operation.

Detailed decoupling recommendations are provided in *Flexible Motherboard Design Guidelines* (order number 243187).

**Note:** Reducing available bulk capacitance could degrade long term system reliability.

### 3.1.3.4 3.3-V Inputs and Outputs

The inputs and outputs of the Pentium processor with MMX technology comply with the 3.3-V JEDEC standard levels. Both inputs and outputs are also TTL-compatible, although the inputs cannot tolerate voltage swings above the  $V_{IN3}$  (max) specification.

System support components which use TTL-compatible inputs will interface to the Pentium processor with MMX technology without extra logic. This is because the Pentium processor drives according to the 5-V TTL specification (but not beyond 3.3 V).

For Pentium processor with MMX technology inputs, the voltage must not exceed the 3.3-V  $V_{IN3}$  (max) specification. System support components can consist of 3.3-V devices or open-collector devices. In an open-collector configuration, the external resistor should be biased to  $V_{CC3}$ .

All pins, including the CLK and PICCLK of the Pentium processor with MMX technology, are 3.3 V-tolerant-only. When an 8259A interrupt controller is used, for example, the system must provide level converters between the 8259A and the Pentium processor with MMX technology.

### 3.1.3.5 NC/INC and Unused Inputs

**Important:** All NC and INC pins must remain unconnected.

For reliable operation, always connect unused inputs to an appropriate signal level. Unused active low inputs should be connected to  $V_{CC3}$ . Unused active high inputs should be connected to  $V_{SS}$  (ground).

### 3.1.3.6 Private Bus

When two Pentium processors with MMX technology are operating in dual processor mode, a “private bus” exists to arbitrate for the processor bus and maintain local cache coherency. The private bus consists of two pinout changes:

- Five pins are added: PBREQ#, PBGNT#, PHIT#, PHITM#, D/P#.
- Ten output pins become I/O pins: ADS#, D/C#, W/R#, M/IO#, CACHE#, LOCK#, HIT#, HITM#, HLDA, SCYC, BE4#.

The new pins are given AC specifications of valid delays at 0 pF, setup times and hold times. Simulate with these parameters and their respective I/O buffer models to guarantee that proper timings are met.

The AC specification gives input setup and hold times for the ten signals that become I/O pins. These setup and hold times must be met only when a dual processor is present in the system.

### 3.1.4 Buffer Models

The structure of the buffer models for the Pentium processor with MMX technology and the Pentium processor are identical. Some of the values of the components have changed to reflect the minor manufacturing process and package differences between the processors. The system should see insignificant differences between the AC behavior of the Pentium processor with MMX technology and the Pentium processor.

Simulation of AC timings using the Pentium processor with MMX technology buffer models is recommended to ensure robust system designs. Pay specific attention to the signal quality restrictions imposed by 3.3-V buffers.

## 3.2 Absolute Maximum Ratings

Table 15 provides stress ratings only. Functional operation at the Absolute Maximum Ratings is not implied or guaranteed. Functional operating conditions are given in the AC and DC specification tables.

Extended exposure to the maximum ratings may affect device reliability. Furthermore, although the Pentium processor with MMX technology contains protective circuitry to resist damage from electrostatic discharge, always take precautions to avoid high static voltages or electric fields.

**Table 15. Absolute Maximum Ratings**

Symbol	Parameter	Min	Max	Unit
	Storage Temperature	-65	150	°C
	Case Temperature Under Bias	-65	110	°C
V <sub>CC3</sub>	V <sub>CC3</sub> Supply Voltage with respect to V <sub>SS</sub>	-0.5	4.6	V
V <sub>CC2</sub>	V <sub>CC2</sub> Supply Voltage with respect to V <sub>SS</sub>	-0.5	3.7	V
V <sub>IN3</sub>	3-V Only Buffer DC Input Voltage	-0.5	V <sub>CC3</sub> +0.5 (not to exceed V <sub>CC3</sub> max)	V

**Warning:** Stressing the device beyond the Absolute Maximum Ratings may cause permanent damage. These are stress ratings only. Operation beyond the DC specifications is not recommended or guaranteed and extended exposure beyond the DC specifications may affect device reliability.



### 3.3 DC Specifications

Tables 16 through 19 list the DC specifications for the Pentium processor with MMX technology.

**Table 16. V<sub>CC</sub> and T<sub>CASE</sub> Specifications**

Symbol	Parameter	Min	Nom.	Max	Unit	Notes
T <sub>CASE</sub>	Case Temperature	0		70	°C	
V <sub>CC2</sub>	V <sub>CC2</sub> Voltage	2.7	2.8	2.9	V	Range = 2.8 ± 3.57%†
V <sub>CC3</sub>	V <sub>CC3</sub> Voltage	3.135	3.3	3.6	V	Range = 3.3 -5%, +9.09%†

† See "V<sub>CC2</sub> and V<sub>CC3</sub> Measurement Specification" on page 34.

**Table 17. 3.3 V DC Specifications**

Symbol	Parameter	Min	Max	Unit	Notes
V <sub>IL3</sub>	Input Low Voltage	-0.3	0.8	V	TTL Level
V <sub>IH3</sub>	Input High Voltage	2.0	V <sub>CC3</sub> +0.3	V	TTL Level <sup>(1)</sup>
V <sub>OL3</sub>	Output Low Voltage		0.4	V	TTL Level <sup>(2, 3)</sup>
V <sub>OH3</sub>	Output High Voltage	2.4		V	TTL Level <sup>(4)</sup>

**NOTES:**

1. Parameter measured at nominal V<sub>CC3</sub> which is 3.3 V.
2. Parameter measured at -4 mA.
3. In dual processing systems, up to a 10 mA load from the second processor may be observed on the PCHK# signal. Based on silicon characterization data, V<sub>OL3</sub> of PCHK# will remain less than 400 mV even with a 10 mA load. PCHK# V<sub>OL3</sub> will increase to approximately 500 mV with a 14 mA load (worst case for a DP system with a 4 mA system load).
4. Parameter measured at 3 mA.

**Table 18. ICC Specifications**

Measured at V<sub>CC2</sub>=2.9 V and V<sub>CC3</sub>=3.6 V

Symbol	Parameter	Min	Max	Unit	Notes
I <sub>CC2</sub>	Power Supply Current		6500 5700	mA mA	233 MHz 200 MHz†
I <sub>CC3</sub>	Power Supply Current		750 650	mA mA	233 MHz 200 MHz†

† This value should be used for power supply design. It was determined using a worst case instruction mix and maximum V<sub>CC</sub>. Power supply transient response and decoupling capacitors must be sufficient to handle the instantaneous current changes occurring during transitions from Stop Clock to full Active modes.



**Table 19. Input and Output Characteristics**

Symbol	Parameter	Min	Max	Unit	Notes
$C_{IN}$	Input Capacitance		15	pF	Guaranteed by design
$C_O$	Output Capacitance		20	pF	Guaranteed by design
$C_{I/O}$	I/O Capacitance		25	pF	Guaranteed by design
$C_{CLK}$	CLK Input Capacitance		15	pF	Guaranteed by design
$C_{TIN}$	Test Input Capacitance		15	pF	Guaranteed by design
$C_{TOUT}$	Test Output Capacitance		20	pF	Guaranteed by design
$C_{TCK}$	Test Clock Capacitance		15	pF	Guaranteed by design
$I_{LI}$	Input Leakage Current		±15	µA	$0 < V_{IN} < V_{IL}$ , $V_{IH} > V_{IN} > V_{CC}$ , Note 1
$I_{LO}$	Output Leakage Current		±15	µA	$0 < V_{IN} < V_{IL}$ , $V_{IH} > V_{IN} > V_{CC}$ , Note 1
$I_{IH}$	Input Leakage Current		200	µA	$V_{IN} = 2.4$ V, Note 2
$I_{IL}$	Input Leakage Current		-400	µA	$V_{IN} = 0.4$ V, Notes 3, 4

**NOTES:**

1. This parameter is for inputs/outputs without an internal pull-up or pull-down.
2. This parameter is for inputs with an internal pull-down.
3. This parameter is for inputs with an internal pull-up.
4. This specification applies to the HITM# pin when it is driven as an input (e.g., in JTAG mode).

### 3.4 AC Specifications

The AC specifications consist of output delays, input setup requirements and input hold requirements. All AC specifications (with the exception of those for the TAP signals and APIC signals) are relative to the rising edge of the CLK input.

All timings are referenced to 1.5 volts for both “0” and “1” logic levels unless otherwise specified. Within the sampling window, a synchronous input must be stable for correct Pentium processor with MMX technology operation.

Each valid delay is specified for a 0 pF load. The system designer should use I/O buffer modeling to account for signal flight time delays.

Each Pentium processor with MMX technology specified to operate within a single bus-to-core ratio and a specific minimum to maximum bus frequency range (corresponding to a minimum to maximum core frequency range). Operation in other bus-to-core ratios or outside the specified operating frequency range is not supported. For example, the 166 MHz Pentium processor with MMX technology does not operate beyond the 66 MHz bus frequency and only supports the 2/5 bus-to-core ratio; it does not support the 1/3, 1/2, or 2/3 bus-to-core ratios. Table 5 summarizes these specifications.

**Table 20. AC Specifications (Sheet 1 of 4)**

 See Table 16 for  $V_{CC}$  and  $T_{CASE}$  specifications,  $C_L = 0$  pF

Symbol	Parameter	Min	Max	Unit	Figure	Notes
	Frequency	33.33	66.6	MHz	7	
$t_{1a}$	CLK Period	15.0	30.0	ns	7	
$t_{1b}$	CLK Period Stability		±250	ps		Adjacent Clocks, Notes 1, 25
$t_2$	CLK High Time	4.0		ns	7	2 V, Note 1
$t_3$	CLK Low Time	4.0		ns	7	0.8 V, Note 1
$t_4$	CLK Fall Time	0.15	1.5	ns	7	2.0 V – 0.8 V Notes 1, 5
$t_5$	CLK Rise Time	0.15	1.5	ns	7	0.8 V – 2.0 V Notes 1, 5
$t_{6a}$	PWT, PCD, CACHE# Valid Delay	1.0	7.0	ns	8	
$t_{6b}$	AP Valid Delay	1.0	8.5	ns	8	
$t_{6c}$	BE7#–BE0#, LOCK# Valid Delay	0.9	7.0	ns	8	4
$t_{6d}$	ADS# Valid Delay	0.8	6.0	ns	8	
$t_{6e}$	ADSC#, D/C#, W/R#, SCYC, Valid Delay	0.8	7.0	ns	8	
$t_{6f}$	M/O# Valid Delay	0.8	5.9	ns	8	
$t_{6g}$	A16–A3 Valid Delay	0.5	6.6	ns	8	
$t_{6h}$	A31–A17 Valid Delay	0.6	6.6	ns	8	
$t_7$	ADS#, ADSC#, AP, A31–A3, PWT, PCD, BE7#–BE0#, M/O#, D/C#, W/R#, CACHE#, SCYC, LOCK# Float Delay		10.0	ns	9	1
$t_{8a}$	APCHK#, IERR#, FERR# Valid Delay	1.0	8.3	ns	8	4
$t_{8b}$	PCHK# Valid Delay	1.0	7.0	ns	8	4
$t_{9a}$	BREQ Valid Delay	1.0	8.0	ns	8	4
$t_{9b}$	SMIACK# Valid Delay	1.0	7.3	ns	8	4
$t_{9c}$	HLDA Valid Delay	1.0	6.8	ns	8	
$t_{10a}$	HIT# Valid Delay	1.0	6.8	ns	8	
$t_{10b}$	HITM# Valid Delay	0.7	6.0	ns	8	
$t_{11a}$	PM1–PM0, BP3–BP0 Valid Delay	1.0	10.0	ns	8	
$t_{11b}$	PRDY Valid Delay	1.0	8.0	ns	8	
$t_{12}$	D63–D0, DP7–DP0 Write Data Valid Delay	1.3	7.5	ns	8	
$t_{13}$	D63–D0, DP3–DP0 Write Data Float Delay		10.0	ns	9	1
$t_{14}$	A31–A5 Setup Time	6.0		ns	10	26
$t_{15}$	A31–A5 Hold Time	1.0		ns	10	
$t_{16a}$	INV, AP Setup Time	5.0		ns	10	
$t_{16b}$	EADS# Setup Time	5.0		ns	10	
$t_{17}$	EADS#, INV, AP Hold Time	1.0		ns	10	

**NOTE:** See Table 21 for notes.

**Table 20. AC Specifications (Sheet 2 of 4)**

 See Table 16 for  $V_{CC}$  and  $T_{CASE}$  specifications,  $C_L = 0$  pF

Symbol	Parameter	Min	Max	Unit	Figure	Notes
$t_{18a}$	KEN# Setup Time	5.0		ns	10	
$t_{18b}$	NA#, WB/WT# Setup Time	4.5		ns	10	
$t_{19}$	KEN#, WB/WT#, NA# Hold Time	1.0		ns	10	
$t_{20}$	BRDY#, BRDYC# Setup Time	5.0		ns	10	
$t_{21}$	BRDY#, BRDYC# Hold Time	1.0		ns	10	
$t_{22}$	AHOLD, BOFF# Setup Time	5.5		ns	10	
$t_{23}$	AHOLD, BOFF# Hold Time	1.0		ns	10	
$t_{24a}$	BUSCHK#, EWBE#, HOLD Setup Time	5.0		ns	10	
$t_{24b}$	PEN# Setup Time	4.8		ns	10	
$t_{25a}$	BUSCHK#, EWBE#, PEN# Hold Time	1.0		ns	10	
$t_{25b}$	HOLD Hold Time	1.5		ns	10	
$t_{26}$	A20M#, INTR, STPCLK# Setup Time	5.0		ns	10	Notes 12, 16
$t_{27}$	A20M#, INTR, STPCLK# Hold Time	1.0		ns	10	13
$t_{28}$	INIT, FLUSH#, NMI, SMI#, IGNNE# Setup Time	5.0		ns	10	Notes 12, 16, 17
$t_{29}$	INIT, FLUSH#, NMI, SMI#, IGNNE# Hold Time	1.0		ns	10	13
$t_{30}$	INIT, FLUSH#, NMI, SMI#, IGNNE# Pulse Width, Async	2.0		CLK		Notes 15, 17
$t_{31}$	R/S# Setup Time	5.0		ns	10	Notes 12, 16, 17
$t_{32}$	R/S# Hold Time	1.0		ns	10	13
$t_{33}$	R/S# Pulse Width, Async.	2.0		CLK		Notes 15, 17
$t_{34}$	D0–D63, DP0–7 Read Data Setup Time	2.8		ns	10	
$t_{35}$	D0–D63, DP0–7 Read Data Hold Time	1.5		ns	10	
$t_{36}$	RESET Setup Time	5.0		ns	11	Notes 12, 16
$t_{37}$	RESET Hold Time	1.0		ns	11	13
$t_{38}$	RESET Pulse Width, $V_{CC}$ & CLK Stable	15.0		CLK	11	17
$t_{39}$	RESET Active After $V_{CC}$ & CLK Stable	1.0		ms	11	Power up
$t_{40}$	Reset Configuration Signals (INIT, FLUSH#) Setup Time	5.0		ns	11	Notes 12, 16, 17
$t_{41}$	Reset Configuration Signals (INIT, FLUSH#) Hold Time	1.0		ns	11	13
$t_{42a}$	Reset Configuration Signals (INIT, FLUSH#) Setup Time, Async.	2.0		CLK		To RESET falling edge, Note 16
$t_{42b}$	Reset Configuration Signals (INIT, FLUSH#, BRDYC#, BUSCHK#) Hold Time, Async.	2.0		CLK		To RESET falling edge, Note 27

**NOTE:** See Table 21 for notes.



**Table 20. AC Specifications (Sheet 3 of 4)**

See Table 16 for V<sub>CC</sub> and T<sub>CASE</sub> specifications, C<sub>L</sub> = 0 pF

Symbol	Parameter	Min	Max	Unit	Figure	Notes
t <sub>42c</sub>	Reset Configuration Signals (BRDYC#, BUSCHK#) Setup Time, Async.	3.0		CLK		To RESET falling edge, Note 27
t <sub>43a</sub>	BF0, BF1, CPUTYP Setup Time	1.0		ms	11	To RESET falling edge, Note 22
t <sub>43b</sub>	BF0, BF1, CPUTYP Hold Time	2.0		CLK		To RESET falling edge, Note 22
t <sub>43c</sub>	APICEN, BE4# Setup Time	2.0		CLK		To RESET falling edge
t <sub>43d</sub>	APICEN, BE4# Hold Time	2.0		CLK		To RESET falling edge
t <sub>44</sub>	TCK Frequency		16.0	MHz		
t <sub>45</sub>	TCK Period	62.5		ns	7	
t <sub>46</sub>	TCK High Time	25.0		ns	7	2 V, Note 1
t <sub>47</sub>	TCK Low Time	25.0		ns	7	0.8 V Note 1
t <sub>48</sub>	TCK Fall Time		5.0	ns	7	2.0 V – 0.8 V, Notes 1, 8, 9
t <sub>49</sub>	TCK Rise Time		5.0	ns	7	0.8 V – 2.0 V, Notes 1, 8, 9
t <sub>50</sub>	TRST# Pulse Width	40.0		ns	13	Asynchronous, Note 1
t <sub>51</sub>	TDI, TMS Setup Time	5.0		ns	12	7
t <sub>52</sub>	TDI, TMS Hold Time	13.0		ns	12	7
t <sub>53</sub>	TDO Valid Delay	2.5	20.0	ns	12	8
t <sub>54</sub>	TDO Float Delay		25.0	ns	12	Notes 1, 8
t <sub>55</sub>	All Non-Test Outputs Valid Delay	2.5	20.0	ns	12	Notes 3, 8, 10
t <sub>56</sub>	All Non-Test Outputs Float Delay		25.0	ns	12	Notes 1, 3, 8, 10
t <sub>57</sub>	All Non-Test Inputs Setup Time	5.0		ns	12	Notes 3, 7, 10
t <sub>58</sub>	All Non-Test Inputs Hold Time	13.0		ns	12	Notes 3, 7, 10
<b>APIC AC Specifications</b>						
t <sub>60a</sub>	PICCLK Frequency	2.0	16.66	MHz	7	
t <sub>60b</sub>	PICCLK Period	60.0	500.0	ns	7	
t <sub>60c</sub>	PICCLK High Time	15.0		ns	7	
t <sub>60d</sub>	PICCLK Low Time	15.0		ns	7	
t <sub>60e</sub>	PICCLK Rise Time	0.15	2.5	ns	7	
t <sub>60f</sub>	PICCLK Fall Time	0.15	2.5	ns	7	
t <sub>60g</sub>	PICD1–PICD0 Setup Time	3.0		ns	10	To PICCLK
t <sub>60h</sub>	PICD1–PICD0 Hold Time	2.5		ns	10	To PICCLK
t <sub>60i</sub>	PICD1–PICD0 Valid Delay (LtoH)	4.0	38.0	ns	8	From PICCLK, Note 28
t <sub>60j</sub>	PICD1–PICD0 Valid Delay (HtoL)	4.0	22.0	ns	8	From PICCLK, Note 28
t <sub>80a</sub>	PBREQ#, PBGNT#, PHIT# Flight Time	0.0	2.0	ns	8	Notes 11, 24

**NOTE:** See Table 21 for notes.

**Table 20. AC Specifications (Sheet 4 of 4)**

 See Table 16 for  $V_{CC}$  and  $T_{CASE}$  specifications,  $C_L = 0$  pF

Symbol	Parameter	Min	Max	Unit	Figure	Notes
$t_{80b}$	PHITM# Flight Time	0.0	1.8	ns	8	Notes 11, 24
$t_{83a}$	A31–A5 Setup Time	3.7		ns	10	18
$t_{83b}$	D/C#, W/R#, CACHE#, LOCK#, SCYC Setup Time	4.0		ns	10	Notes 18, 21
$t_{83c}$	ADS#, M/IO# Setup Time	5.8		ns	10	Notes 18, 21
$t_{83d}$	HIT#, HITM# Setup Time	6.0		ns	10	Notes 18, 21
$t_{83e}$	HLDA Setup Time	6.0		ns	10	Notes 18, 21
$t_{84a}$	CACHE#, HIT# Hold Time	1.0		ns	10	Notes 18, 21
$t_{84b}$	ADS#, D/C#, W/R#, M/IO#, A31–A5, HLDA, SCYC Hold Time	0.8		ns	10	Notes 18, 21
$t_{84c}$	LOCK# Hold Time	0.9		ns	10	Notes 18, 21
$t_{84d}$	HITM# Hold Time	0.7		ns	10	Notes 18, 21
$t_{85}$	DPEN# Valid Time		10.0	CLK		Notes 18, 19, 23
$t_{86}$	DPEN# Hold Time	2.0		CLK		Notes 18, 20, 23
$t_{87}$	APIC ID (BE3#–BE0#) Setup Time	2.0		CLK	11	To falling Edge of RESET, Note 23
$t_{88}$	APIC ID (BE3#–BE0#) Hold Time	2.0		CLK	11	From Falling Edge of RESET, Note 23
$t_{89}$	D/P# Valid Delay	1.0	8.0	ns	8	Primary Processor Only

**NOTE:** See Table 21 for notes.

Table 21. Notes for Table 20

**NOTES:**

Notes 2, 6 and 14 are general and apply to all standard TTL signals used with the Pentium® processor family. Each valid delay is specified for a 0 pF load. The system designer should use I/O buffer models to account for signal flight time delays.

1. Not 100% tested. Guaranteed by design/characterization.
2. TTL input test waveforms are assumed to be 0 to 3 V transitions with 1 V/ns rise and fall times.
3. Non-test outputs and inputs are the normal output or input signals (besides TCK, TRST#, TDI, TDO and TMS). These timings correspond to the response of these signals due to boundary scan operations.
4. APCHK#, FERR#, HLDA, IERR#, LOCK# and PCHK# are glitch-free outputs. Glitch-free signals monotonically transition without false transitions.
5.  $0.8 \text{ V/ns} \leq \text{CLK input rise/fall time} \leq 8 \text{ V/ns}$ .
6.  $0.3 \text{ V/ns} \leq \text{input rise/fall time} \leq 5 \text{ V/ns}$ .
7. Referenced to TCK rising edge.
8. Referenced to TCK falling edge.
9. 1 ns can be added to the maximum TCK rise and fall times for every 10 MHz of frequency below 33 MHz.
10. During debugging, do not use the boundary scan timings ( $t_{55}$  to  $t_{58}$ ).
11. This is a flight time specification, that includes both flight time and clock skew. The flight time is the time from where the unloaded driver crosses 1.5 V (50% of min  $V_{CC}$ ), to where the receiver crosses the 1.5 V level (50% of min  $V_{CC}$ ). See Figure 14. The minimum flight time minus the clock skew must be greater than zero.
12. Setup time is required to guarantee recognition on a specific clock. Pentium® processor with MMX™ technology must meet this specification for dual processor operation for the FLUSH# and RESET signals.
13. Hold time is required to guarantee recognition on a specific clock. Pentium processor with MMX technology must meet this specification for dual processor operation for the FLUSH# and RESET signals.
14. All TTL timings are referenced from 1.5 V.
15. To guarantee proper asynchronous recognition, the signal must have been deasserted (inactive) for a minimum of two clocks before being returned active and must meet the minimum pulse width.
16. This input may be driven asynchronously. However, when operating two processors in dual processing mode, FLUSH# and RESET must be asserted synchronously to both processors.
17. When driven asynchronously, RESET, NMI, FLUSH#, R/S#, INIT and SMI# must be deasserted (inactive) for a minimum of two clocks before being returned active.
18. Timings are valid only when dual processor is present.
19. Maximum time DPEN# is valid from rising edge of RESET.
20. Minimum time DPEN# is valid after falling edge of RESET.
21. The D/C#, M/IO#, W/R#, CACHE# and A31–A5 signals are sampled only on the CLK that ADS# is active.
22. In order to override the internal defaults and guarantee that the BF1–BF0 inputs remain stable while RESET is active, these pins should be strapped directly to or through a pull-up/pull-down resistor to  $V_{CC3}$  or ground. Driving these pins with active logic is not recommended unless stability during RESET can be guaranteed. Similarly, CPUTYP should also be strapped directly to or through a pull-up/pull-down resistor to  $V_{CC3}$  or ground.
23. RESET is synchronous in dual processing mode. All signals which have a setup or hold time with respect to a falling or rising edge of RESET in UP mode, should be measured with respect to the first processor clock edge in which RESET is sampled either active or inactive in dual processing mode.
24. The PHIT# and PHITM# signals operate at the core frequency.
25. These signals are measured on the rising edge of adjacent CLKs at 1.5 V. To ensure a 1:1 relationship between the amplitude of the input jitter and the internal and external clocks, the jitter frequency spectrum should not have any power spectrum peaking between 500 kHz and 1/3 of the CLK operating frequency. The amount of jitter present must be accounted for as a component of CLK skew between devices. The internal clock generator requires a constant frequency CLK input to within  $\pm 250$  ps. Therefore, the CLK input cannot be changed dynamically.
26. In dual processing mode, timing  $t_{14}$  is replaced by  $t_{83a}$ . Timing  $t_{14}$  is required for external snooping (e.g., address setup to the CLK in which EADS# is sampled active) in both uniprocessor and dual processor modes.
27. BRDYC# and BUSCHK# are used as reset configuration signals to select buffer size.
28. This assumes an external pull-up resistor to  $V_{CC}$  and a lumped capacitive load. The pull-up resistor must be between 300  $\Omega$  and 1 K $\Omega$ , the capacitance must be between 20 pF and 120 pF, and the RC product must be between 6 ns and 36 ns. VOL for PICD1–PICD0 is 0.55 V.

Figure 7. Clock Waveform

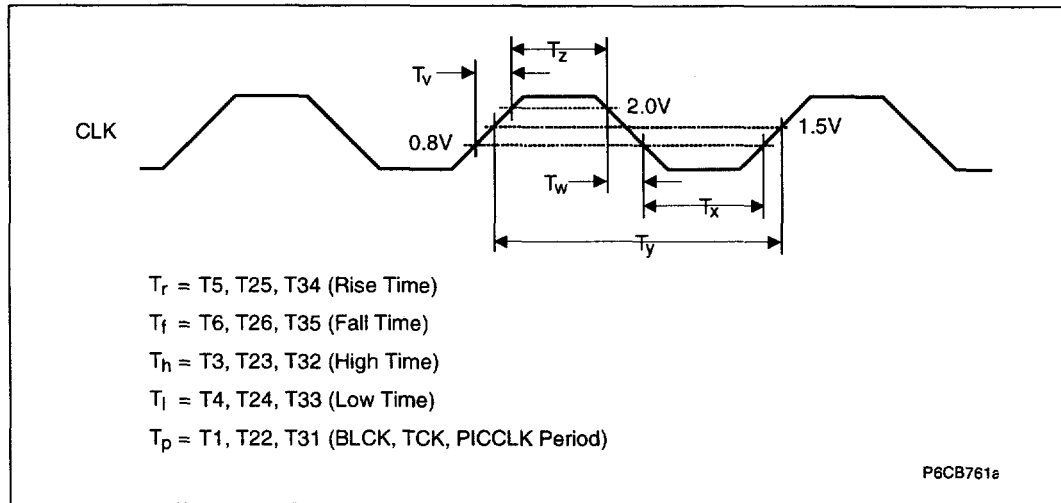

Figure 8. Valid Delay Timings

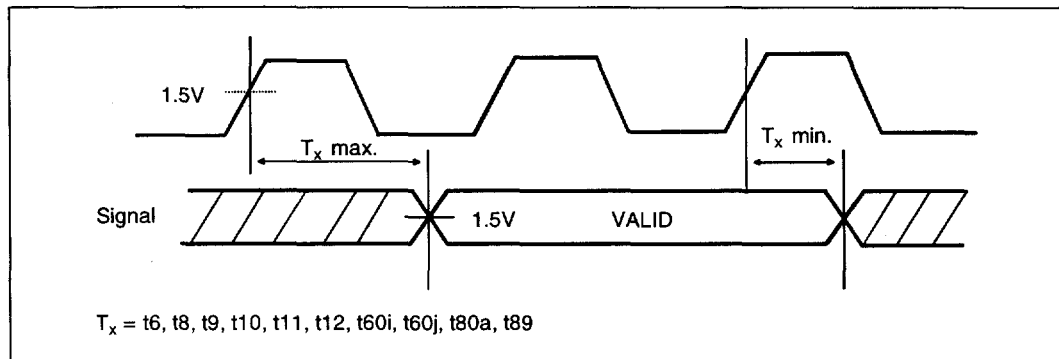
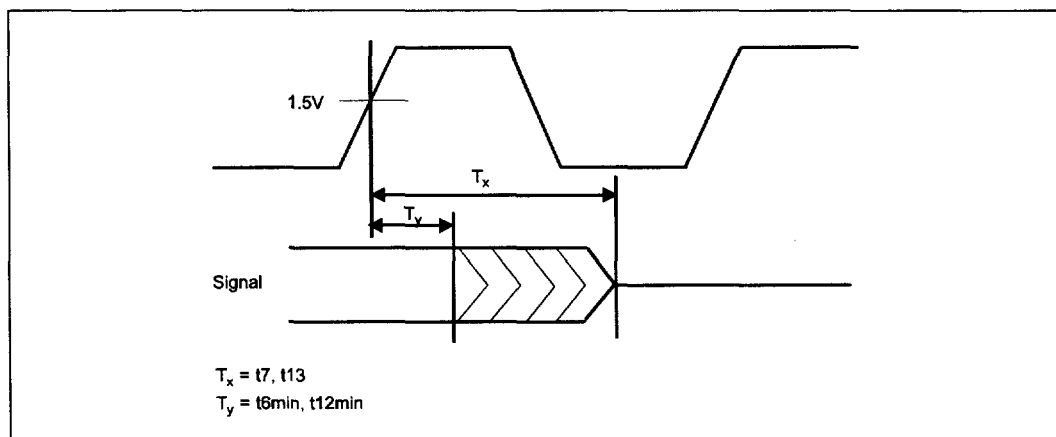
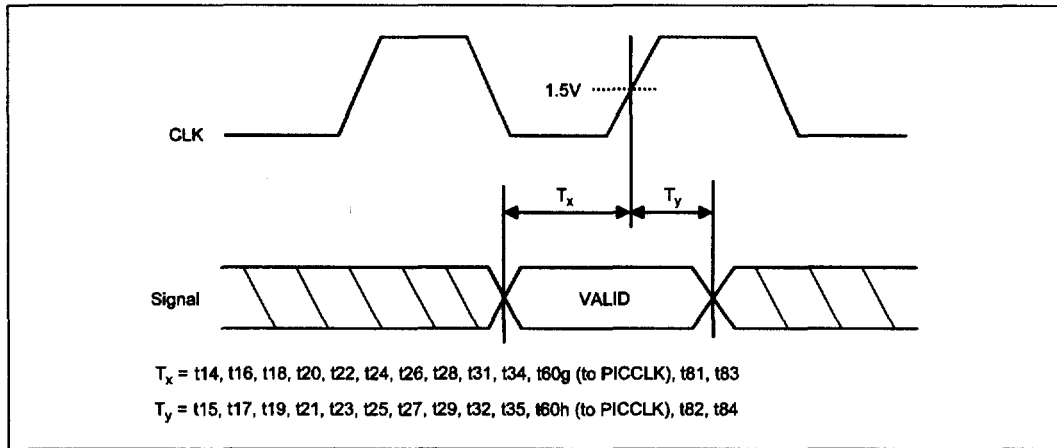

Figure 9. Float Delay Timings



**Figure 10. Setup and Hold Timings**



**Figure 11. Reset and Configuration Timings**

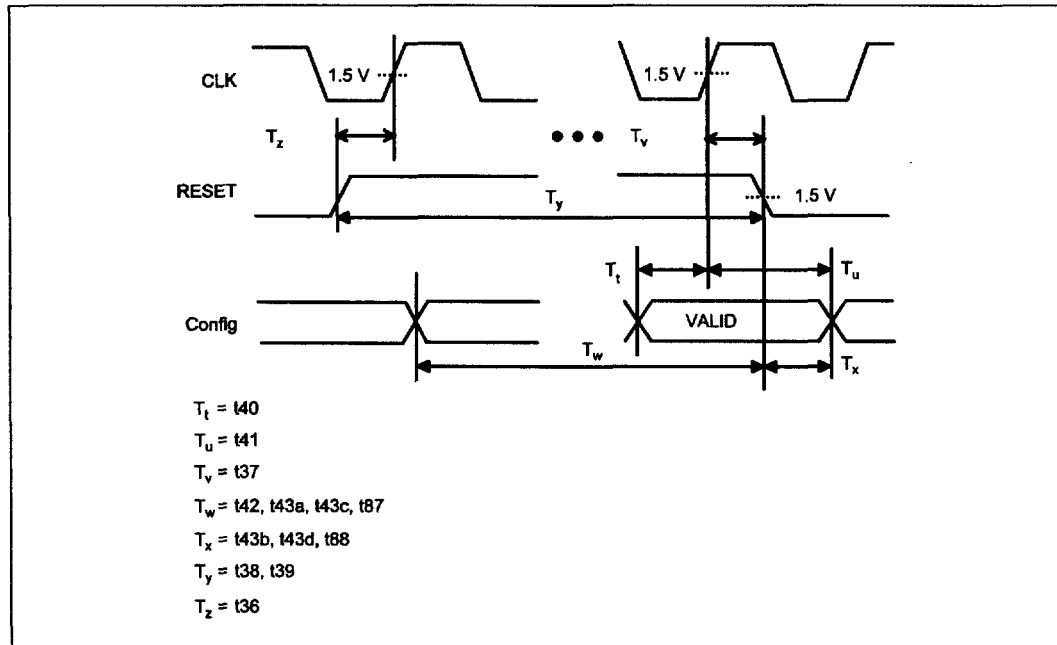



Figure 12. Test Timings

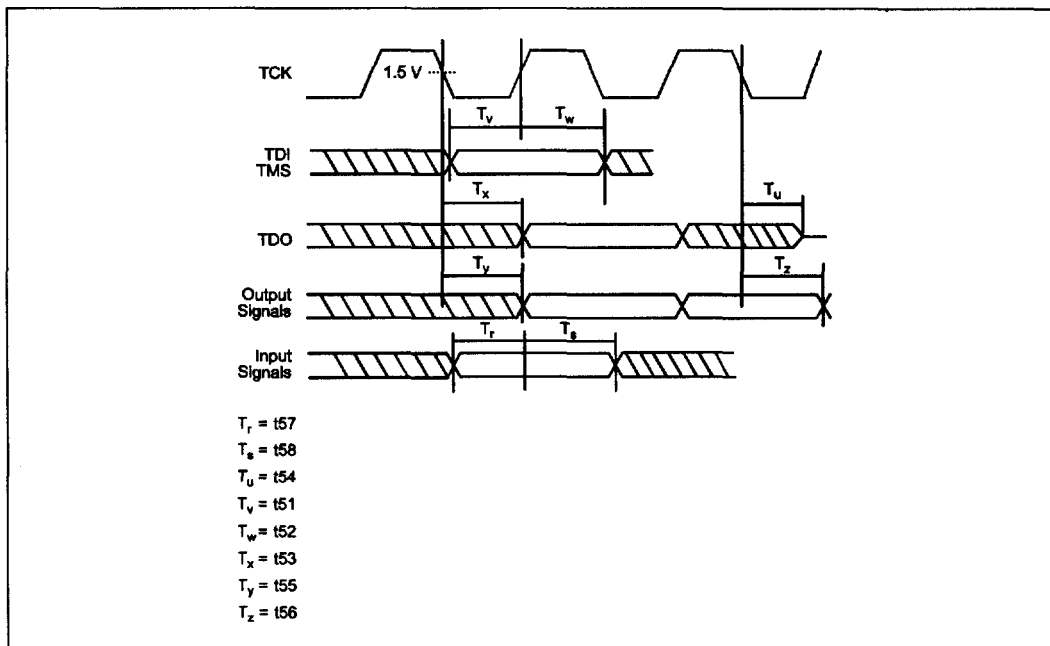

Figure 13. Test Reset Timings

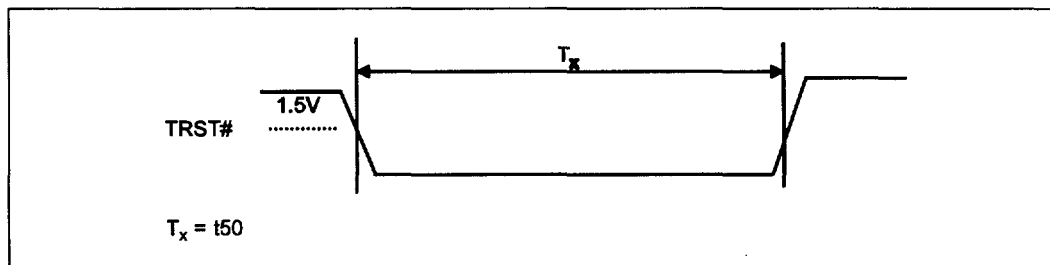

Figure 14. 50 Percent  $V_{CC}$  Measurement of Flight Time

