

FOR 18AWG & 20-24AWG & 26-30AWG

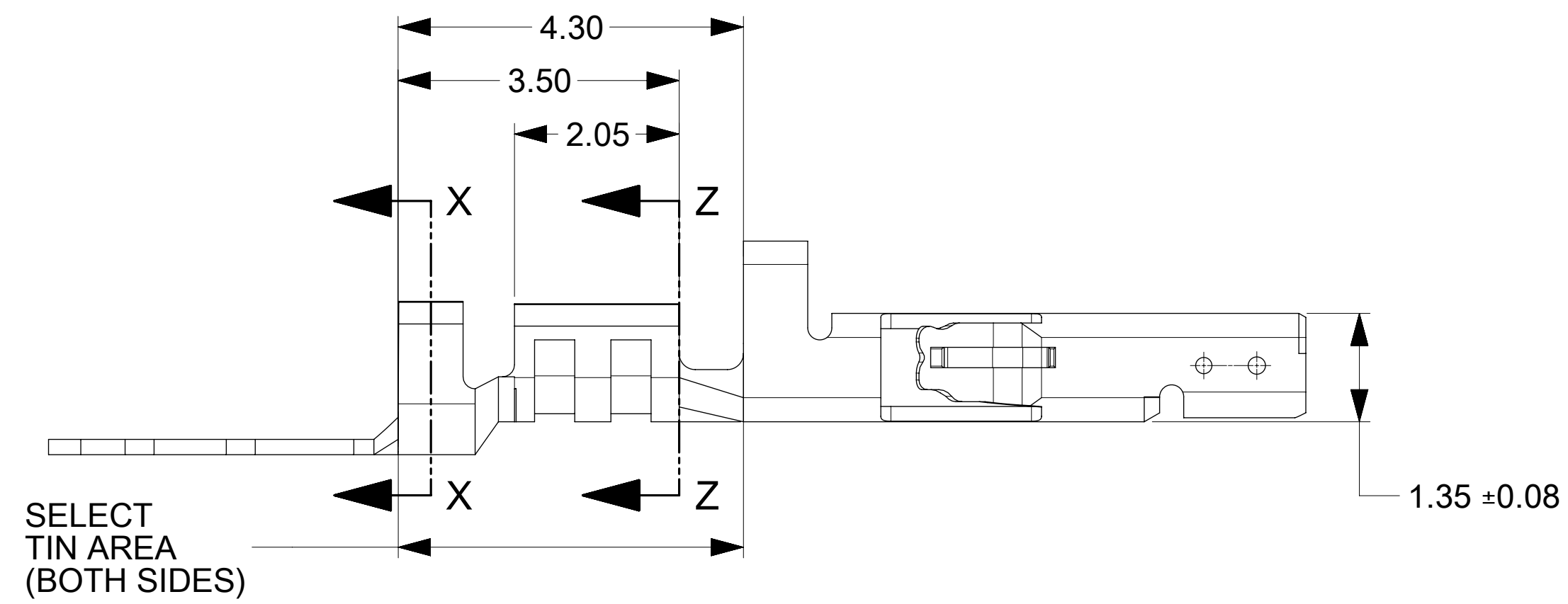

FOR 16AWG

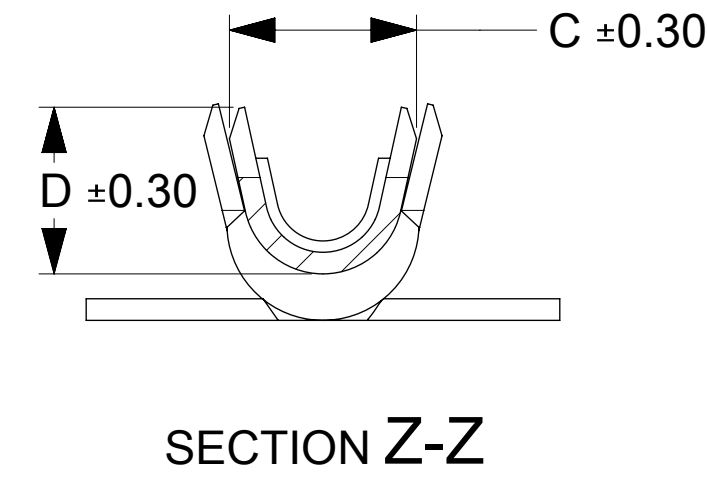
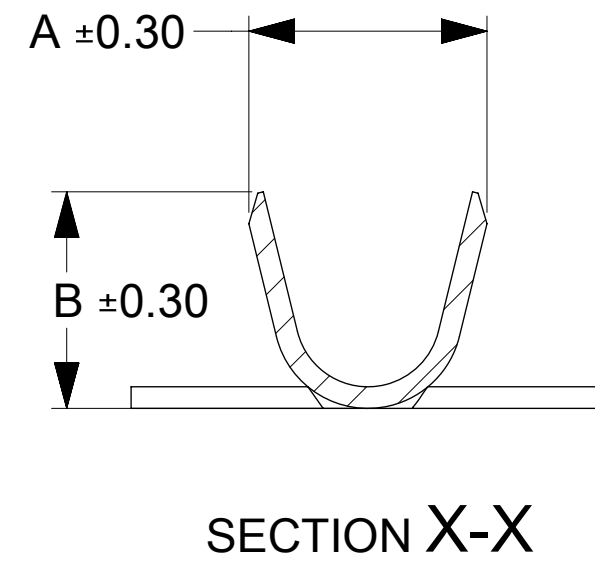
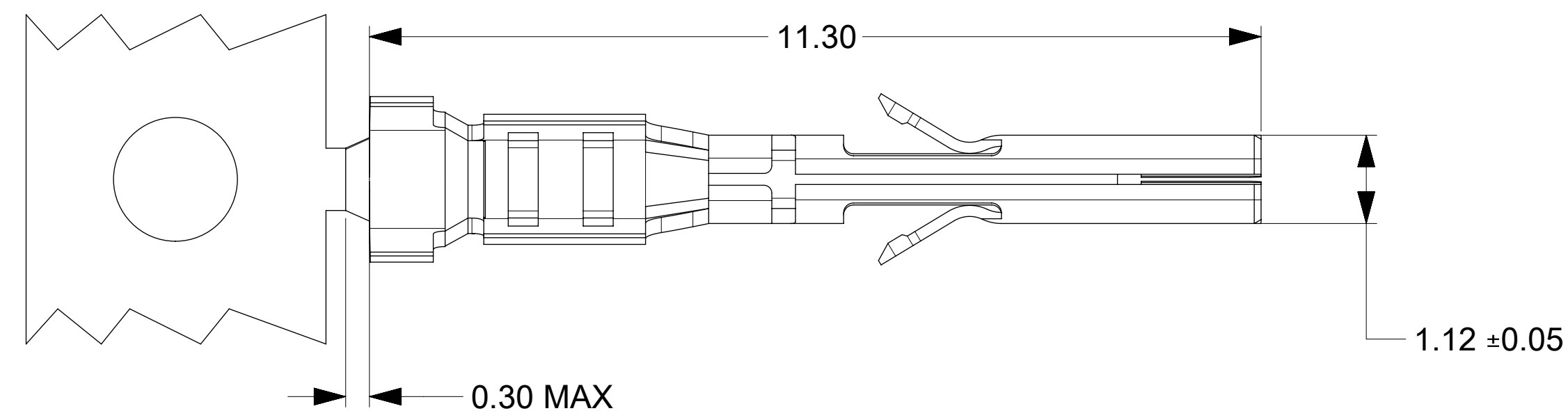
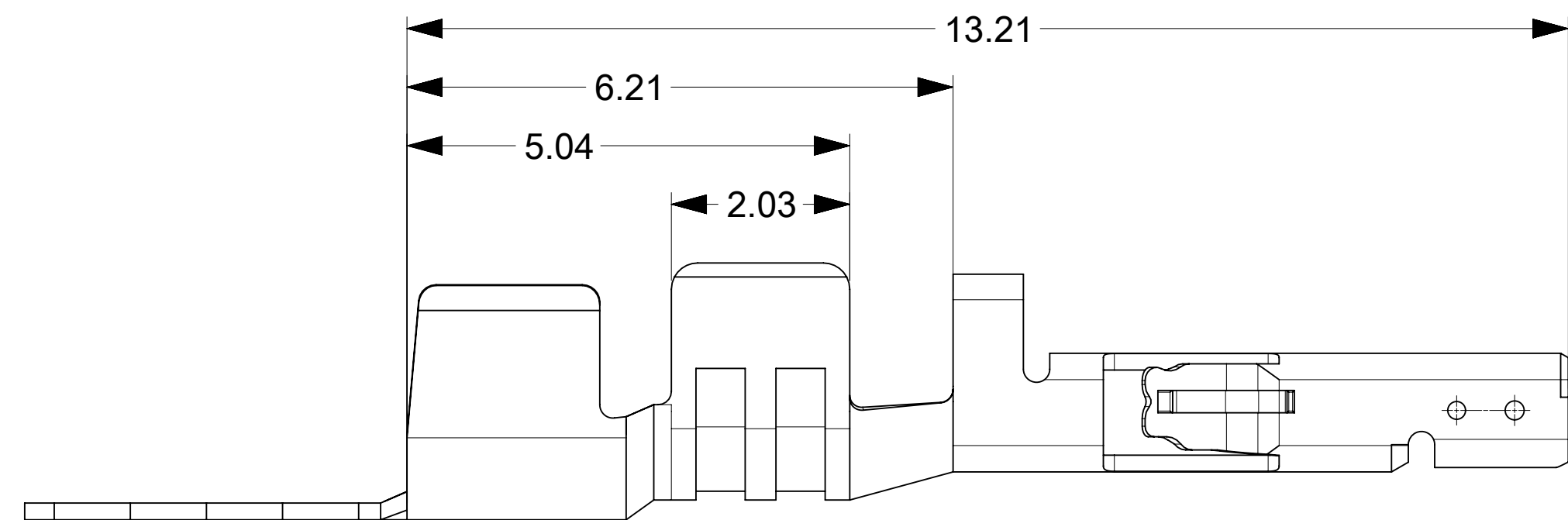

PART NUMBER	CONTACT PLATING OPTION	WIRE SIZE	ASSEMBLY OPTION	LUBRICATED	A	B	C	D
2064600011	OPTION 1	26-30 AWG	CHAIN	YES	2.10	1.91	1.65	1.47
2064600021		20-24 AWG			2.51	2.31	2.08	1.91
2064600031		18 AWG			2.51	2.31	2.39	2.18
2064600041		16 AWG			2.97	2.67	2.70	2.70
2064600012	OPTION 2	26-30 AWG	CHAIN	NO	2.10	1.91	1.65	1.47
2064600022		20-24 AWG			2.51	2.31	2.08	1.91
2064600032		18 AWG			2.51	2.31	2.39	2.18
2064600042		16 AWG			2.97	2.67	2.70	2.70
2064600013	OPTION 3	26-30 AWG	CHAIN	NO	2.10	1.91	1.65	1.47
2064600023		20-24 AWG			2.51	2.31	2.08	1.91
2064600033		18 AWG			2.51	2.31	2.39	2.18
2064600043		16 AWG			2.97	2.67	2.70	2.70

NOTES:

- MATERIAL: HIGH COPPER ALLOY
- PLATING :
  - OPTION 1: TIN 2.5 μm MIN OVER ALL, OVER NICKEL 1.25 μm MIN OVERALL
  - OPTION 2: 0.38μm(15μ") MIN GOLD CONTACT AREA, 1.52μm(60μ")MIN MATTE TIN CRIMP AREA, OVER NICKEL 1.27μm(50μ")MIN OVERALL
  - OPTION 3: 0.76μm(30μ") MIN GOLD CONTACT AREA, 1.52μm(60μ")MIN MATTE TIN CRIMP AREA, OVER NICKEL 1.27μm(50μ")MIN OVERALL
- PRODUCT SPECIFICATION: 2064600000-PS
- PACKAGING SPECIFICATION: 2064600000-PK
- TERMINAL FOR USE IN RECEPTACLE SERIES 206461
- COSMETIC SPECIFICATION: PS-45499-002 CLASS B

THIS DRAWING CONTAINS INFORMATION THAT IS PROPRIETARY TO MOLEX ELECTRONIC TECHNOLOGIES, LLC AND SHOULD NOT BE USED WITHOUT WRITTEN PERMISSION									
DIMENSION UNITS <b>mm</b>		SCALE <b>NTS</b>		CURRENT REV DESC:				<b>molex</b>	
GENERAL TOLERANCES (UNLESS SPECIFIED)				EC NO: 758590					
ANGULAR TOL ± 3.0°				DRWN: ZIXUAG 2023/08/02				FEMALE TERMINAL MICRO-FIT + SOLUTION	
4 PLACES ±				CHK'D: XQZHANG 2023/08/09					
3 PLACES ±				APPR: XQZHANG 2023/08/09				PRODUCT CUSTOMER DRAWING	
2 PLACES ± 0.25				INITIAL REVISION:					
1 PLACE ± 0.35				DRWN: SMAHAJANSHET 2018/05/08				DOCUMENT NUMBER <b>2064600000-SD</b>	
0 PLACES ±				APPR: NCSR 2019/04/02					
DRAFT WHERE APPLICABLE MUST REMAIN WITHIN DIMENSIONS		THIRD ANGLE PROJECTION		DRAWING <b>D-SIZE</b>		SERIES <b>206460</b>		DOC PART <b>000</b>	
						MATERIAL NUMBER SEE TABLE		REVISION <b>A4</b>	
						CUSTOMER GENERAL MARKET		SHEET NUMBER 1 OF 1	