

REVISIONS					
P	LTR	DESCRIPTION	DATE	DWN	APVD
	W2	REVISED PER ECR-23-178295	11JUL2023	SA	DM

SPECIFICATIONS:

MATERIALS:

CASE: GLASS FILLED PPS, UL94V-0 BROWN
 COVER: STAINLESS STEEL
 ACTUATOR BUTTON: SEE TABLE - UL94V-0
 MOVING CONTACT: COPPER ALLOY, SILVER CLAD
 MOVING CONTACT: (1571563-1,-2,-7&-8), STAINLESS STEEL, AG CLAD OVER NICKEL
 FIXED CONTACT/TERMINAL, COPPER ALLOY-SILVER OVER NICKEL PLATE

ELECTRICAL:

MAX CONTACT RATING: 50MILLIAMPS@24V DC
 MIN CONTACT RATING: 10MICROAMPS@1V DC
 INITIAL CONTACT RESISTANCE: 100 MILLIOHMS MAX.
 INSULATION RESISTANCE: 100 MEGOHMS AT 100 VDC MIN.
 DIELECTRIC STRENGTH: 500 VAC 50/60 Hz FOR 1 MINUTE.
 LIFE EXPECTANCY: (SEE TABLE)

MECHANICAL:

ACTUATION FORCE: (SEE TABLE)
 ACTUATION TRAVEL: 0.25 +0.20/-0.10 [.010 +.008/-.004]

ENVIRONMENTAL:

OPERATING TEMPERATURE: -40°C TO +85°C
 STORAGE TEMPERATURE: -40°C TO +85°C
 SOLDER HEAT RESISTANCE PER 109-201, CONDITION B

SOLDERABILITY:

SPECIFICATION EIA-364-52, CLASS 1, CATEGORY 2

- 1 TAPE AND REEL PACKAGING PER EIA 481.
- 2 ALL MATERIALS AND FINISHES SHALL COMPLY WITH EU DIRECTIVE 2002/95/EC OF 27JAN2003 (ROHS)

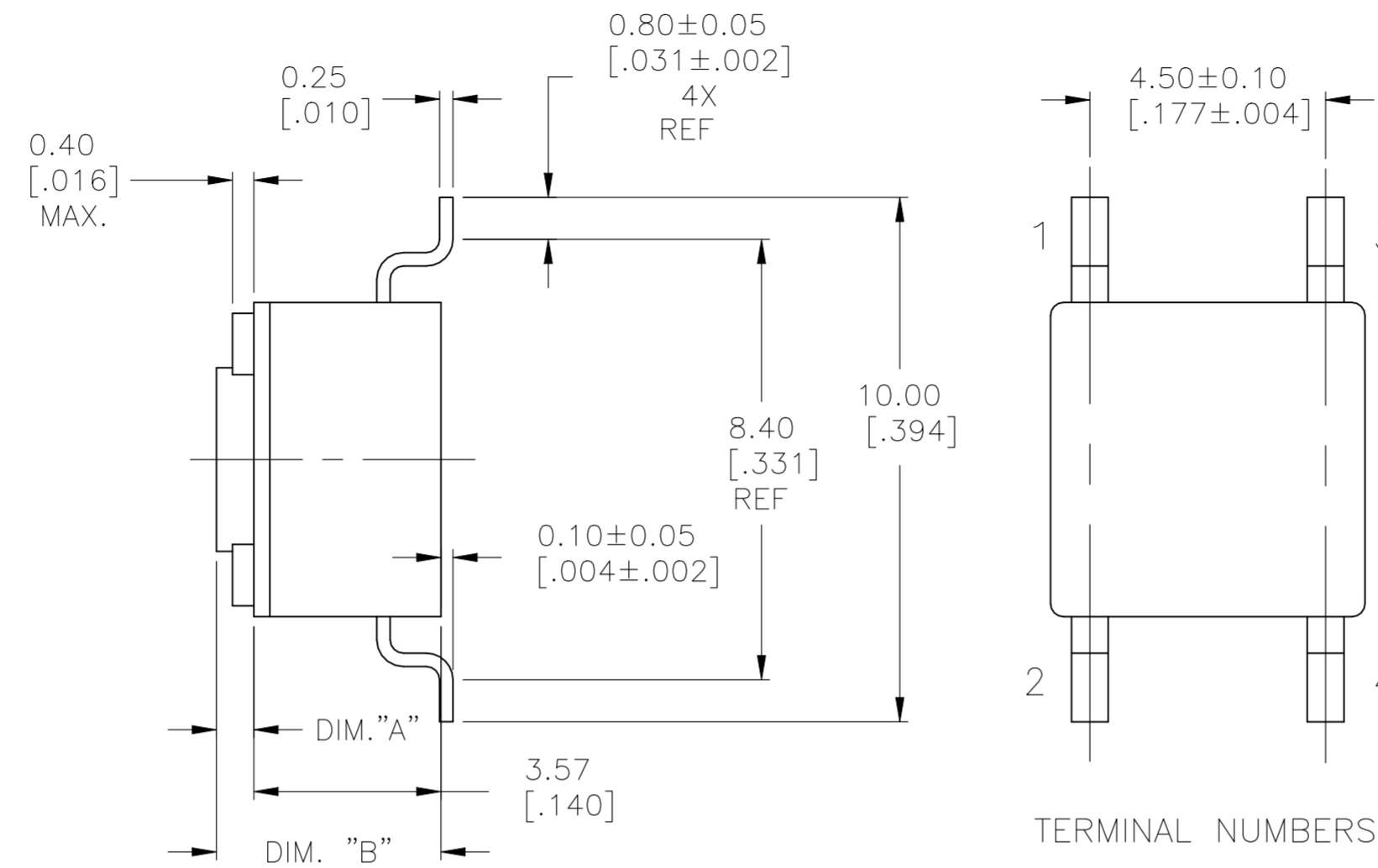
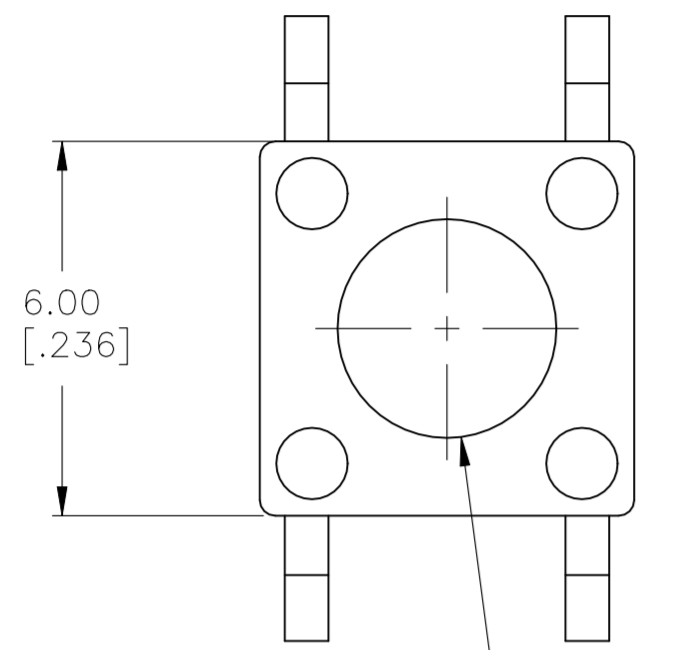

TERMINAL NUMBERS

FSM2JSMA AS SHOWN

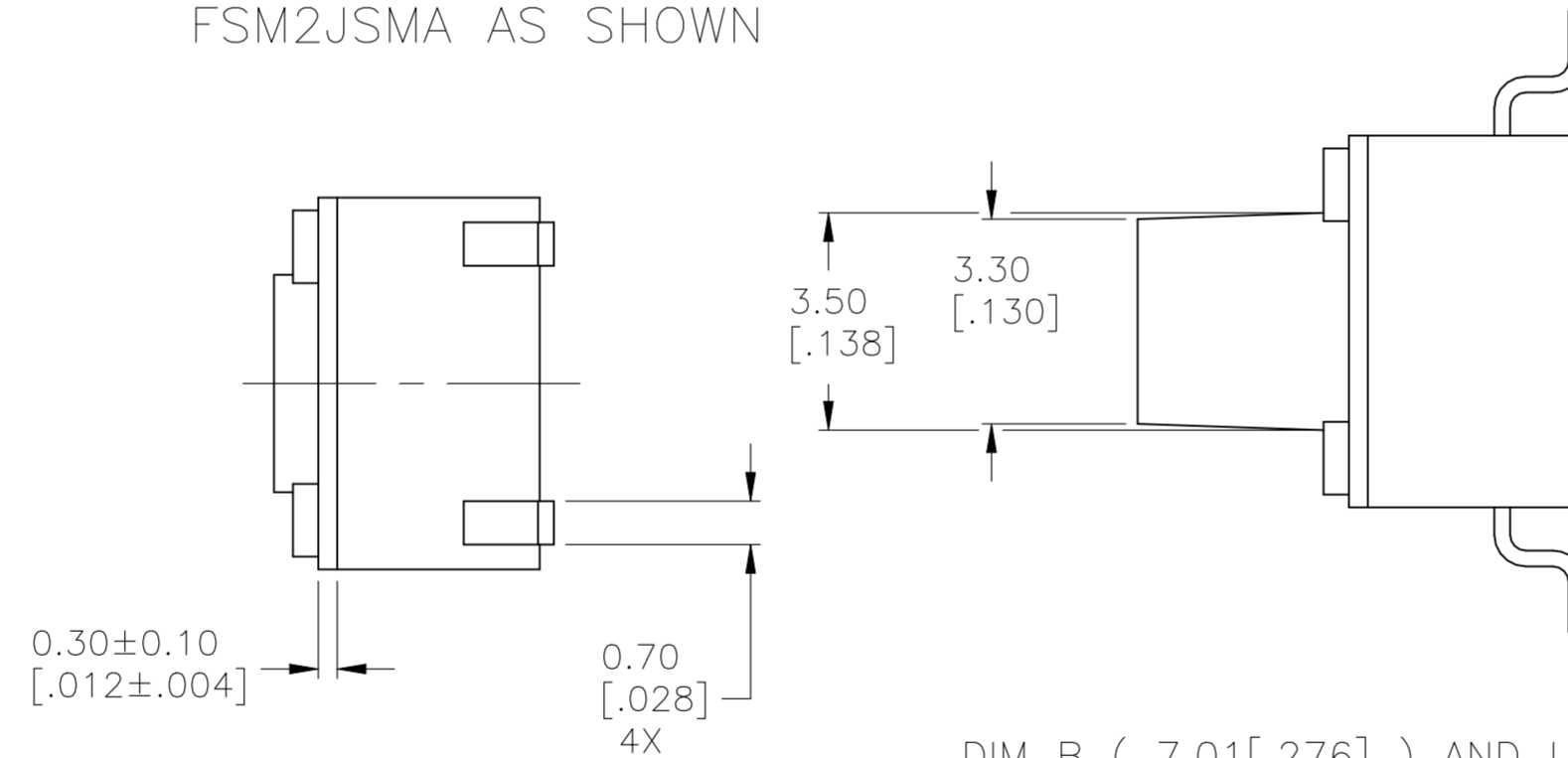
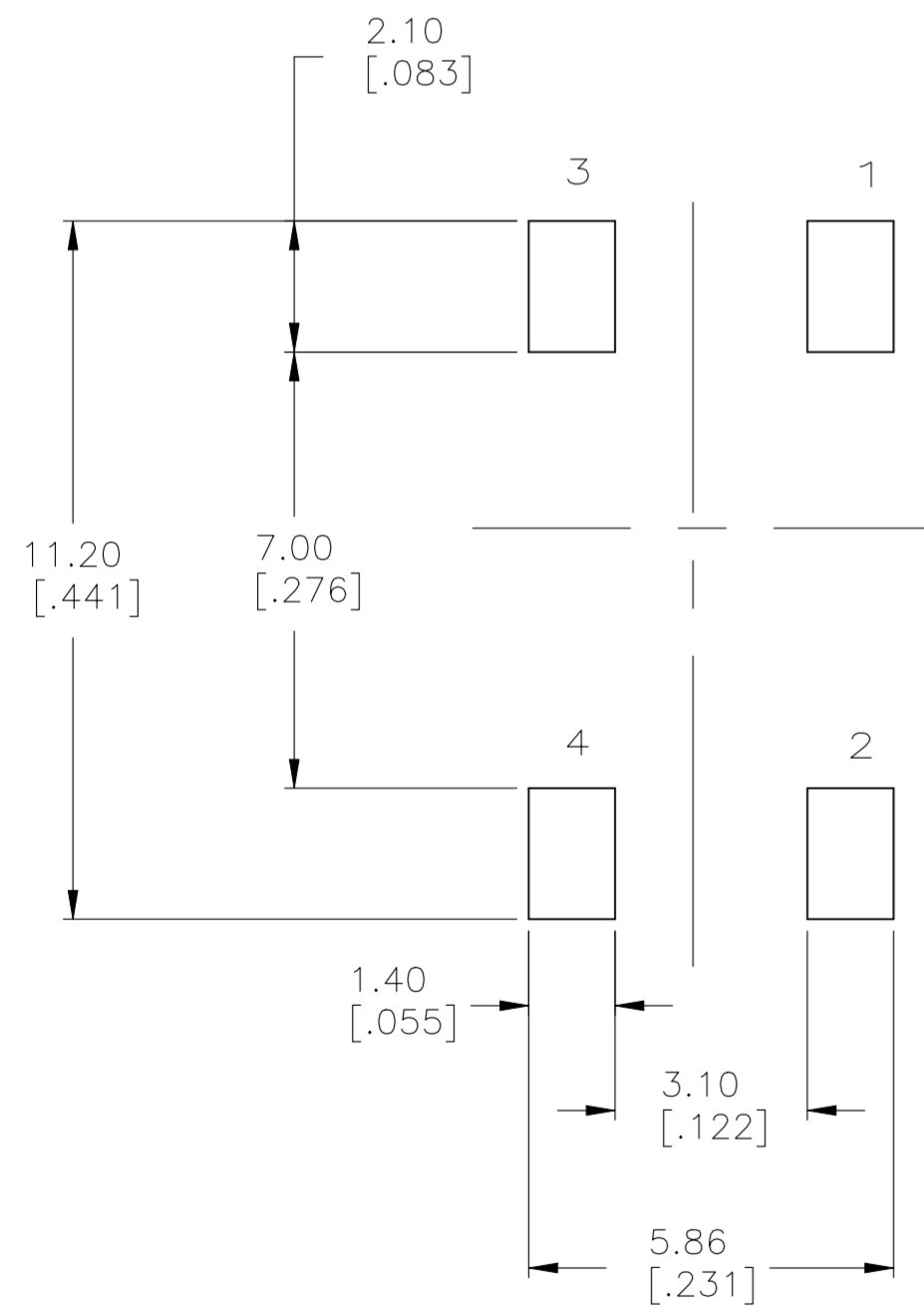

DIM B (7.01 [.276]) AND LONGER MODELS

()-INDICATES MOMENTARY POSITION		
CIRCUIT CHARACTERISTICS		
CONTACT POSITION	CIRCUIT DIAGRAM	
OFF	(ON)	
	1 - 3 2 - 4	

THIS DRAWING IS A CONTROLLED DOCUMENT.		DWN D.SARKISIAN 04MAY04																				
DIMENSIONS: mm [INCHES]		CHK D.SARKISIAN 22APR94																				
TOLERANCES UNLESS OTHERWISE SPECIFIED:		APVD D.SARKISIAN 22APR94	NAME MICRO MINIATURE PUSHBUTTON SWITCH FSM JSM																			
<table border="0"> <tr> <td>0 PLC</td> <td>±</td> <td>-</td> </tr> <tr> <td>1 PLC</td> <td>±</td> <td>-</td> </tr> <tr> <td>2 PLC</td> <td>±</td> <td>0.30[.012]</td> </tr> <tr> <td>3 PLC</td> <td>±</td> <td>-</td> </tr> <tr> <td>4 PLC</td> <td>±</td> <td>-</td> </tr> <tr> <td>ANGLES</td> <td>±</td> <td>1°</td> </tr> </table>		0 PLC	±	-	1 PLC	±	-	2 PLC	±	0.30[.012]	3 PLC	±	-	4 PLC	±	-	ANGLES	±	1°	PRODUCT SPEC -	SIZE A2	
0 PLC	±	-																				
1 PLC	±	-																				
2 PLC	±	0.30[.012]																				
3 PLC	±	-																				
4 PLC	±	-																				
ANGLES	±	1°																				
MATERIAL -		FINISH -	APPLICATION SPEC -	CAGE CODE 00779																		
		WEIGHT	DRAWING NO C=2-1437565-7	RESTRICTED TO -																		
CUSTOMER DRAWING			SCALE 8:1	SHEET 1 OF 2																		
			REV W2																			

REVISIONS				
P	LTR	DESCRIPTION	DATE	APVD
-	-	SEE SHEET 1	-	-

	100,000	BLACK	NYLON	260G±50G	12MM	24MM	13.00±0.10 [.512±.010]	9.40±0.10 [.370±.004]	FSM14JSMAATR	1-1571563-5	
	100,000	WHITE	NYLON	260G±50G	12MM	24MM	13.00±0.10 [.512±.010]	9.40±0.10 [.370±.004]	FSM14JSMAATR	1571563-6	
	100,000	WHITE	NYLON	260G±50G	-	-	13.00±0.10 [.512±.010]	9.40±0.10 [.370±.004]	FSM14JSMAA	1571563-5	
OBSOLETE	100,000	BROWN	NYLON	100G±50G	-	-	13.00±0.10 [.512±.010]	9.40±0.10 [.370±.004]	FSM14JSML	1-1571563-0	
	100,000	WHITE	NYLON	260G±50G	12MM	24MM	9.50±0.10 [.374±.004]	5.89±0.10 [.232±.004]	FSM8JSMAATR	1-1571563-4	
OBSOLETE	100,000	WHITE	NYLON	260G±50G	-	-	9.50±0.10 [.374±.004]	5.89±0.10 [.232±.004]	FSM8JSMAA	1-1571563-3	
	100,000	BLACK	PPS	160G±50G	12MM	24MM	9.50±0.10 [.374±.004]	5.89±0.10 [.232±.004]	FSM8JSMATR	1571563-9	
	100,000	BLACK	PPS	160G±50G	-	-	9.50±0.10 [.374±.004]	5.89±0.10 [.232±.004]	FSM8JSMA	3-1437566-8	
OBSOLETE	100,000	WHITE	NYLON	260G±50G	12MM	24MM	7.01±0.10 [.276±.004]	3.40±0.10 [.134±.004]	FSM6JSMAATR	1-1571563-2	
OBSOLETE	100,000	WHITE	NYLON	260G±50G	-	-	7.01±0.10 [.276±.004]	3.40±0.10 [.134±.004]	FSM6JSMAA	1-1571563-1	
	100,000	BLACK	PPS	160G±50G	12MM	24MM	7.01±0.10 [.276±.004]	3.40±0.10 [.134±.004]	FSM6JSMATR	5-1437565-0	
	100,000	BLACK	PPS	160G±50G	-	-	7.01±0.10 [.276±.004]	3.40±0.10 [.134±.004]	FSM6JSMA	4-1437565-9	
	1,000,000	VIOLET	NYLON	70G±30G	12MM	16MM	4.98±0.25 [.196±.010]	1.40±0.10 [.055±.004]	FSM4JSMXLTR	1571563-2	
	1,000,000	VIOLET	NYLON	70G±30G	-	-	4.98±0.25 [.196±.010]	1.40±0.10 [.055±.004]	FSM4JSMXL	1571563-1	
	100,000	WHITE	NYLON	260G±50G	12MM	16MM	4.98±0.25 [.196±.010]	1.40±0.10 [.055±.004]	FSM4JSMAATR	1571563-4	
OBSOLETE	100,000	WHITE	NYLON	260G±50G	-	-	4.98±0.25 [.196±.010]	1.40±0.10 [.055±.004]	FSM4JSMAA	1571563-3	
	100,000	BLACK	PPS	160G±50G	12MM	16MM	4.98±0.25 [.196±.010]	1.40±0.10 [.055±.004]	FSM4JSMATR	4-1437565-2	
	100,000	BLACK	PPS	160G±50G	-	-	4.98±0.25 [.196±.010]	1.40±0.10 [.055±.004]	FSM4JSMA	4-1437565-1	
	1,000,000	BLUE	NYLON	100G±30G	12MM	16MM	4.98±0.25 [.196±.010]	1.40±0.10 [.055±.004]	FSM4JSMLSTR	1571563-8	
	1,000,000	BLUE	NYLON	100G±30G	-	-	4.98±0.25 [.196±.010]	1.40±0.10 [.055±.004]	FSM4JSMLS	1571563-7	
	100,000	WHITE	NYLON	260G±50G	12MM	16MM	4.29±0.15 [.169±.006]	0.71±0.10 [.028±.004]	FSM2JSMAATR	2-1437565-9	
	100,000	WHITE	NYLON	260G±50G	-	-	4.29±0.15 [.169±.006]	0.71±0.10 [.028±.004]	FSM2JSMAA	2-1437565-8	
	100,000	GRAY	PPS	160G±50G	12MM	16MM	4.29±0.15 [.169±.006]	0.71±0.10 [.028±.004]	FSM2JSMATR	3-1437565-0	
	100,000	GRAY	PPS	160G±50G	-	-	4.29±0.15 [.169±.006]	0.71±0.10 [.028±.004]	FSM2JSMA	2-1437565-7	
	200,000	BROWN	PPS	100±50G	12MM	16MM	4.29±0.15 [.169±.006]	0.71±0.10 [.028±.004]	FSM2JSMLTR	1571527-2	
	200,000	BROWN	PPS	100±50G	-	-	4.29±0.15 [.169±.006]	0.71±0.10 [.028±.004]	FSM2JSML	1571527-1	
LIFE CYCLE	ACTUATOR COLOR	ACTUATOR MATERIAL	ACTUATION FORCE	PITCH	TAPE WIDTH	DIM 'B'		DIM 'A'		T&B PART NUMBER	PART NUMBER

THIS DRAWING IS A CONTROLLED DOCUMENT.		DWN D.SARKISIAN 04MAY04	 TE Connectivity																	
DIMENSIONS: mm [INCHES]		CHK D.SARKISIAN 22APR94																		
TOLERANCES UNLESS OTHERWISE SPECIFIED:		APVD D.SARKISIAN 22APR94																		
<table border="0"> <tr><td>0 PLC</td><td>±</td><td>-</td></tr> <tr><td>1 PLC</td><td>±</td><td>-</td></tr> <tr><td>2 PLC</td><td>±</td><td>0.30[.012]</td></tr> <tr><td>3 PLC</td><td>±</td><td>-</td></tr> <tr><td>4 PLC</td><td>±</td><td>-</td></tr> <tr><td>ANGLES</td><td>±</td><td>1°</td></tr> </table>		0 PLC			±	-	1 PLC	±	-	2 PLC	±	0.30[.012]	3 PLC	±	-	4 PLC	±	-	ANGLES	±
0 PLC	±	-																		
1 PLC	±	-																		
2 PLC	±	0.30[.012]																		
3 PLC	±	-																		
4 PLC	±	-																		
ANGLES	±	1°																		
MATERIAL	FINISH	PRODUCT SPEC APPLICATION SPEC	SIZE A2	CAGE CODE 00779	DRAWING NO C-2-1437565-7	RESTRICTED TO														
CUSTOMER DRAWING			SCALE -	SHEET 2 of 2	REV W2															