

REVISIONS					
REV	ECO	DESCRIPTION	DATE	BY	APPR
A1	--	RELEASE NEW DRAWING	26AUG20	SULLEN	TOMMY
A2	--	REVISED PART DESCRIPTION	10NOV20	JHEAD	DH

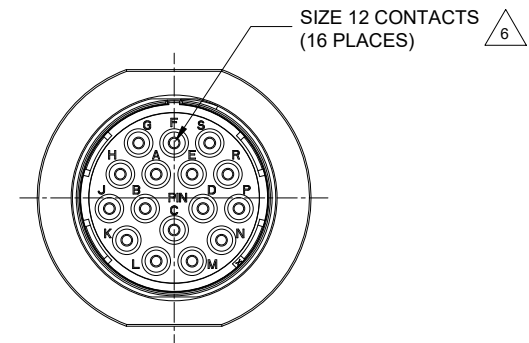
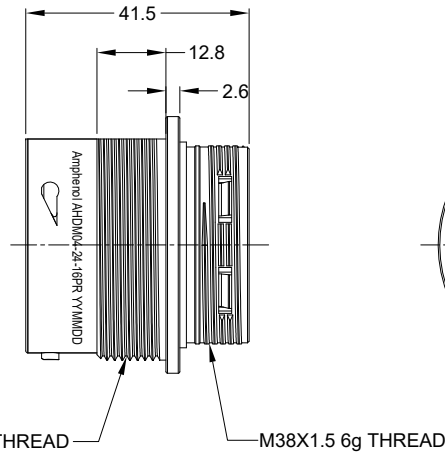
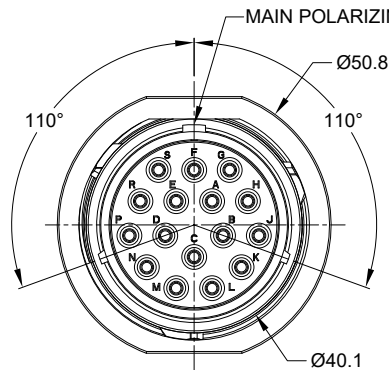

NOTES: UNLESS OTHERWISE SPECIFIED

1. MATERIAL:

SHELL: ZINC ALLOY, NICKEL PLATED
 COUPLING RING: ALUMINUM ALLOY, NICKEL PLATED
 INSERT AND RETAINING RING: THERMOPLASTIC
 SEAL: SILICONE RUBBER

2. MODIFICATIONS: THREADED ADAPTER;
 REDUCED DIA. WIRE SEAL.

3. SPECIFICATIONS:

- 3.1 OPERATING TEMPERATURE: -55°C TO +125°C.
- 3.2 DIELECTRIC WITHSTANDING VOLTAGE: LESS THAN 2 MILLIAMPS CURRENT LEAKAGE @ 1500 VOLTS AC.
- 3.3 INSULATION RESISTANCE: 1000 MEGOHM MIN @ 25°C.
- 3.4 MOISTURE RESISTANCE: IP67&IP69K (MATED CONDITION).
- 3.5 MATING CYCLE DURABILITY: 100 CYCLES
- 3.6 RoHS COMPLIANT

4. MATING PART: AHDM06-24-16S* (* = SEAL TYPE)

5. ALL DIMENSIONS ARE FOR REFERENCE USE ONLY.

6. CONTACT SIZE AND WIRE RANGE:

CONTACT SIZE	MIN. INSUL O.D.	MAX. INSUL O.D.	TYPICAL WIRE RANGE	CURRENT RATING
12	2.46 mm (.097 in)	4.01 mm (.158 in)	10-14 AWG (6.0-2.0mm ²)	25 AMPS

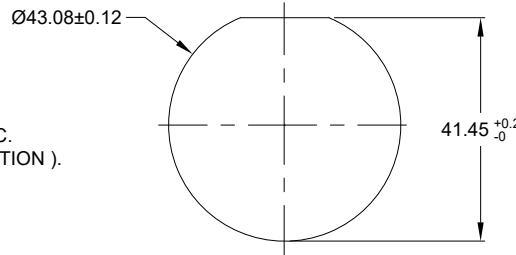

RECOMMENDED PANEL MOUNTING HOLE

RECOMMENDED PANEL THICKNESS: 1.6 TO 4.7MM

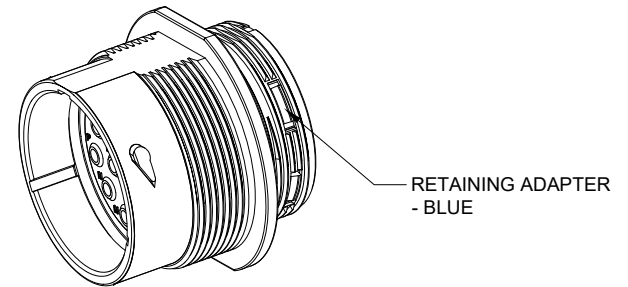

RETAINING ADAPTER - BLUE

QUANTITY	AHDM04-24-16PR	REF: HD34-24-16PE	DESCRIPTION	ITEM																																																												
	PART NUMBER																																																															
<table border="1"> <thead> <tr> <th colspan="2">SIGNATURES</th> <th>DATE</th> </tr> </thead> <tbody> <tr> <td>DRAWN: SULENZHANG</td> <td></td> <td>26AUG20</td> </tr> <tr> <td>CHECKED: ORION LI</td> <td></td> <td>27AUG20</td> </tr> <tr> <td>ENGINEER:</td> <td></td> <td></td> </tr> <tr> <td>APPROVAL: TOMMY XIE</td> <td></td> <td>28AUG20</td> </tr> </tbody> </table>					SIGNATURES		DATE	DRAWN: SULENZHANG		26AUG20	CHECKED: ORION LI		27AUG20	ENGINEER:			APPROVAL: TOMMY XIE		28AUG20																																													
SIGNATURES		DATE																																																														
DRAWN: SULENZHANG		26AUG20																																																														
CHECKED: ORION LI		27AUG20																																																														
ENGINEER:																																																																
APPROVAL: TOMMY XIE		28AUG20																																																														
<table border="1"> <thead> <tr> <th colspan="2">MATERIAL SPECIFICATIONS:</th> <th colspan="3">MATERIALS LIST</th> </tr> </thead> <tbody> <tr> <td colspan="2">UNLESS OTHERWISE SPECIFIED</td> <td colspan="3"> <p>Amphenol</p> <p>Sine Systems - www.amphenol-sine.com 44724 Morley Drive Clinton Township, MI 48036</p> </td> </tr> <tr> <td colspan="2">1) All dimensions are in metric (mm).</td> <td colspan="3"> <p>RECEPTACLE, 24 SZ, 16 PIN, STD ARRANGEMENT, RD SEAL, DURAMATE AHDM</p> </td> </tr> <tr> <td colspan="2">2) Tolerances are as follows:</td> <td colspan="3"> <p>SIZE: B C- DWG NO: AHDM04-24-16PR REVISION: A2</p> </td> </tr> <tr> <td colspan="2">1 PL DEC ±0.30</td> <td colspan="3">SCALE: NONE</td> </tr> <tr> <td colspan="2">2 PL DEC ±0.15</td> <td colspan="3">SHEET 1 OF 1</td> </tr> <tr> <td colspan="2">3 PL DEC ±0.08</td> <td colspan="3"></td> </tr> <tr> <td colspan="2">3) Note reference = </td> <td colspan="3"></td> </tr> <tr> <td colspan="2">MATERIAL SPECIFICATIONS:</td> <td colspan="3"></td> </tr> <tr> <td colspan="2">CUSTOMER:</td> <td colspan="3"></td> </tr> <tr> <td colspan="2">PROCESS SPECIFICATIONS:</td> <td colspan="3"> <p>THIS DRAWING IS SUPPLIED FOR INFORMATION ONLY. DESIGN FEATURES, SPECIFICATIONS AND PERFORMANCE DATA SHOWN HEREON ARE THE PROPERTY OF THE AMPHENOL CORPORATION. NO RIGHTS OF REPRODUCTION ARE IMPLIED. ALL DIMENSIONS ARE SUBJECT TO NORMAL MANUFACTURING VARIATIONS.</p> </td> </tr> <tr> <td colspan="2">NEXT ASSY:</td> <td colspan="3"></td> </tr> </tbody> </table>					MATERIAL SPECIFICATIONS:		MATERIALS LIST			UNLESS OTHERWISE SPECIFIED		<p>Amphenol</p> <p>Sine Systems - www.amphenol-sine.com 44724 Morley Drive Clinton Township, MI 48036</p>			1) All dimensions are in metric (mm).		<p>RECEPTACLE, 24 SZ, 16 PIN, STD ARRANGEMENT, RD SEAL, DURAMATE AHDM</p>			2) Tolerances are as follows:		<p>SIZE: B C- DWG NO: AHDM04-24-16PR REVISION: A2</p>			1 PL DEC ±0.30		SCALE: NONE			2 PL DEC ±0.15		SHEET 1 OF 1			3 PL DEC ±0.08					3) Note reference =					MATERIAL SPECIFICATIONS:					CUSTOMER:					PROCESS SPECIFICATIONS:		<p>THIS DRAWING IS SUPPLIED FOR INFORMATION ONLY. DESIGN FEATURES, SPECIFICATIONS AND PERFORMANCE DATA SHOWN HEREON ARE THE PROPERTY OF THE AMPHENOL CORPORATION. NO RIGHTS OF REPRODUCTION ARE IMPLIED. ALL DIMENSIONS ARE SUBJECT TO NORMAL MANUFACTURING VARIATIONS.</p>			NEXT ASSY:				
MATERIAL SPECIFICATIONS:		MATERIALS LIST																																																														
UNLESS OTHERWISE SPECIFIED		<p>Amphenol</p> <p>Sine Systems - www.amphenol-sine.com 44724 Morley Drive Clinton Township, MI 48036</p>																																																														
1) All dimensions are in metric (mm).		<p>RECEPTACLE, 24 SZ, 16 PIN, STD ARRANGEMENT, RD SEAL, DURAMATE AHDM</p>																																																														
2) Tolerances are as follows:		<p>SIZE: B C- DWG NO: AHDM04-24-16PR REVISION: A2</p>																																																														
1 PL DEC ±0.30		SCALE: NONE																																																														
2 PL DEC ±0.15		SHEET 1 OF 1																																																														
3 PL DEC ±0.08																																																																
3) Note reference =																																																																
MATERIAL SPECIFICATIONS:																																																																
CUSTOMER:																																																																
PROCESS SPECIFICATIONS:		<p>THIS DRAWING IS SUPPLIED FOR INFORMATION ONLY. DESIGN FEATURES, SPECIFICATIONS AND PERFORMANCE DATA SHOWN HEREON ARE THE PROPERTY OF THE AMPHENOL CORPORATION. NO RIGHTS OF REPRODUCTION ARE IMPLIED. ALL DIMENSIONS ARE SUBJECT TO NORMAL MANUFACTURING VARIATIONS.</p>																																																														
NEXT ASSY:																																																																

TITLE: RECEPTACLE ARRANGEMENT 24SZ16PIN STD
 DWG NO: AHDM04-24-16PR
 REV: A2
 SHEET 1 OF 1

A Series™ - Contact Size 12 Options (Works with: AHD-6, ATP, ATHD, DuraMate and PanelMate Series)

Machined Contacts, Sockets & Pins				
Part Number	Description	Size	AWG	Type
*AT60-204-12141-10	Male Contact - Pin, Nickel-plated	12	10-12	Machined
*AT62-203-12141-10	Female Contact - Socket, Nickel-plated	12	10-12	Machined
AT60-220-1231	Male Contact - Pin, Gold-plated	12	12-14	Machined
AT62-210-1231	Female Contact - Socket, Gold-plated	12	12-14	Machined
AT60-204-12141	Male Contact - Pin, Nickel-plated	12	12-14	Machined
AT62-203-12141	Female Contact - Socket, Nickel-plated	12	12-14	Machined

*Works with ATP Series only

DiagnosticGrade™ Machined Contacts, Sockets & Pins				
• Smaller AWG for Diagnostic Applications • Gold-plated • Increased Mating Cycles • Cost-effective				
Part Number	Description	Size	AWG	Type
65-54749	Male Contact - DiagnosticGrade™, Pin, Gold-plated	12	20	Machined
AT62-210-1231-1820	Female Contact - DiagnosticGrade™, Socket, Gold-plated	12	20	Machined

Tooling - Machined Contacts	
Part Number	Description
AUTK-12	Hand Crimp Tool, Size 12
AUTK-100	Universal Heavy Duty Contact Crimping Tool Kit, Size 12/16/20
CA-5D12	Universal Hand Crimp Tool, Size 12/16/20
CA-5E12	Pneumatic Crimp Tool, Size 12/16/20
M300-25A	Hand Crimp Tool used with Crimp Locator MFX-3966, Size 12, 10AWG
MFX-3966	Contact Locator used with Hand Crimp Tool M300-25A, Size 12, 10AWG

Contact Removal Tools (For both Machined or Stamped & Formed Contacts)	
Part Number	Description
ATRT-100	Contact and Wedgelock Extraction Tool
AT11-337-1205	Contact Removal Tool, Plastic, Size 12

Sealing Plugs (For both Machined or Stamped & Formed Contacts)	
Part Number	Description
A114017	Sealing Plug, Size 12, White

Stamped & Formed Contacts, Sockets & Pins				
Part Number	Description	Size	AWG	Type
AT60-12-0244	Male Contact - Pin, Gold-plated	12	10-12	Stamped & Formed
AT62-12-0244	Female Contact - Socket, Gold-plated	12	10-12	Stamped & Formed
AT60-12-0222	Male Contact - Pin, Nickel-plated	12	10-12	Stamped & Formed
AT62-12-0222	Female Contact - Socket, Nickel-plated	12	10-12	Stamped & Formed
AT60-12-0144	Male Contact - Pin, Gold-plated	12	12-14	Stamped & Formed
AT62-12-0144	Female Contact - Socket, Gold-plated	12	12-14	Stamped & Formed
AT60-12-0166	Male Contact - Pin, Nickel-plated	12	12-14	Stamped & Formed
AT62-12-0166	Female Contact - Socket, Nickel-plated	12	12-14	Stamped & Formed

Tooling - Stamped & Formed Contacts	
Part Number	Description
MFX-3973	Crimp Die - Size 12
MFX-3985	Crimp Die - Ssize 12, 10-12AWG -02XX Series
ATT-12-00	Hand Crimp Tool - Size 12, 12AWG
ATT-12-01	Hand Crimp Tool - Size 12, 10AWG