

REVISIONS					
REV	ECO	DESCRIPTION	DATE	BY	APPR
A1	-	RELEASE NUMBER	27MAY20	VITO	TOMMY
A2	-	CHANGE IP RATE FROM IP67 TO IP67&IP69K	27OCT20	VITO	TOMMY

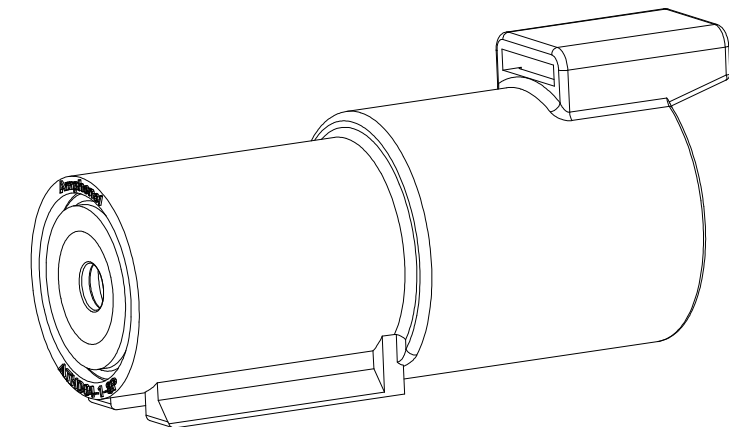
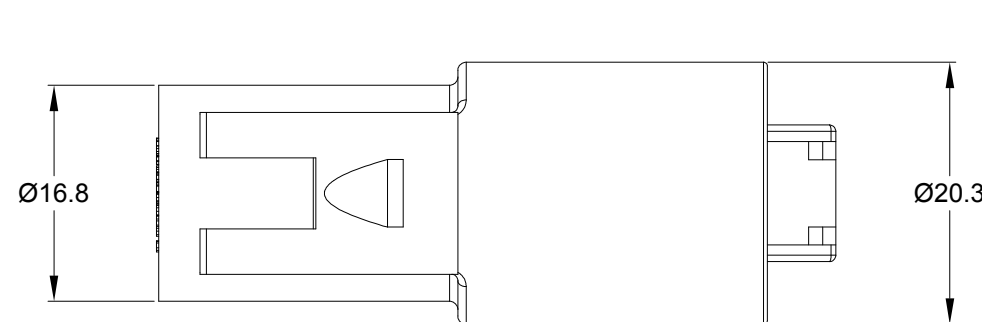
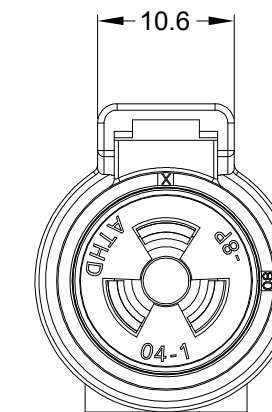
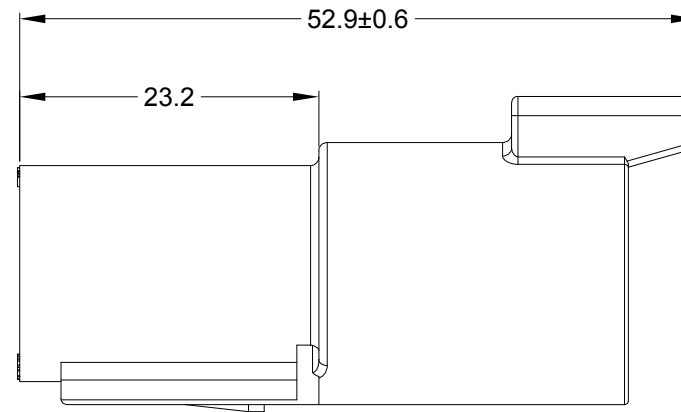
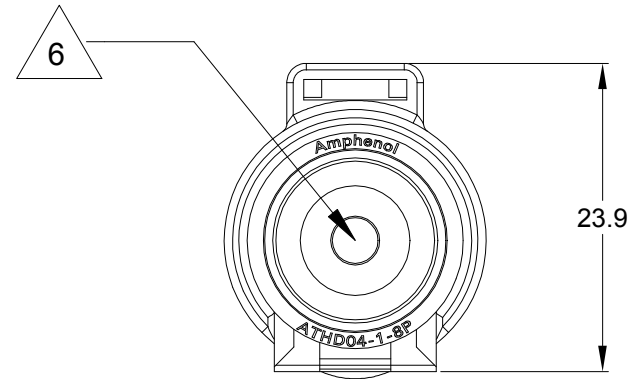

**NOTES: UNLESS OTHERWISE SPECIFIED**

1. MATERIAL:  
HOUSING: THERMOPLASTIC; COLOR:BLACK  
SEAL: SILICONE RUBBER
2. MODIFICAIONS:IN LINE
3. SPECIFICATIONS:
  - 3.1 CURRENT RATING: 60 AMPS
  - 3.2 OPERATING TEMPERATURE: -55°C TO +125°C
  - 3.3 DIELECTRIC WITHSTANDING VOLTAGE: LESS THAN 2 MILLIAMPS CURRENT LEAKAGE @ 1500 VOLTS AC.
  - 3.4 INSULATION RESISTANCE: 1000 MEGOHMS MIN @ 25°C.
  - 3.5 MOISTURE RESISTANCE: IP67&IP69K ( MATED CONDITION )
  - 3.6 MATING CYCLE DURABILITY: 100 CYCLES
  - 3.7 RoHS COMPLIANT
4. MATING PART:ATHD06-1-8S\* PLUG  
(\* = MODIFICATIONS )
5. ALL DIMENSIONS ARE FOR REFERENCE USE ONLY.
6. CONTACT SIZE AND REAR SEAL WIRE RANGE:

CONTACT SIZE	MIN. INSUL O.D.	MAX. INSUL O.D.	TYPICAL WIRE RANGE
08	4.83 mm (.190 in)	6.09 mm (.240 in)	8 - 10 AWG (8.0-5.0 mm <sup>2</sup> )

TITLE: 1 POS, RECEPTACLE, PIN, ATHD SERIES, SIZE 8, BLACK  
 DWG NO.: ATHD04-1-8P  
 REV: A2  
 SH: 1  
 OF: 1

ATHD04-1-8P		DESCRIPTION		ITEM
QUANTITY	PART NUMBER	MATERIALS LIST		
UNLESS OTHERWISE SPECIFIED		SIGNATURES		DATE
1) All dimensions are in metric(mm).		DRAWN:	VITO	27/OCT/20
2) Tolerances are as follows:		CHECKED:	ORION	28/OCT/20
1 PL DEC ±0.30		ENGINEER:		
2 PL DEC ±0.15		APPROVAL:	TOMMY	29/OCT/20
3 PL DEC ±0.08		CUSTOMER:		
3) Note reference =		THIS DRAWING IS SUPPLIED FOR INFORMATION ONLY. DESIGN FEATURES, SPECIFICATIONS AND PERFORMANCE DATA SHOWN HEREON ARE THE PROPERTY OF THE AMPHENOL CORPORATION. NO RIGHTS OF REPRODUCTION ARE IMPLIED. ALL DIMENSIONS ARE SUBJECT TO NORMAL MANUFACTURING VARIATIONS.		
MATERIAL SPECIFICATIONS:		SINE SYSTEMS - www.amphenol-sine.com 44724 Morley Drive Clinton Township, MI 48036		
PROCESS SPECIFICATIONS:		1 POS, RECEPTACLE, PIN, ATHD SERIES, SIZE 8, BLACK		
NEXT ASSY:		SIZE	B	REVISION
		TYPE	C-	A2
		DWG NO:	ATHD04-1-8P	
		SCALE:	NONE	SHEET 1 OF 1

## A Series™ - Contact Size 8 Options (Works with: ATHD and DuraMate Series)

Machined Contacts, Pins and Sockets					
Part Number	Description	Size	AWG	Type	Amps
AT60-204-08141	Male Contact - Pin, Copper Alloy, Nickel-Plated	8	8-10	Machined	60A
AT62-203-08141	Female Contact - Socket, Copper Alloy, Nickel-Plated	8	8-10	Machined	60A
AT60-204-08141-16	Male Contact - Pin, Copper Alloy, Nickel-Plated	8	6	Machined	60A
AT62-203-08141-16	Female Contact - Socket, Copper Alloy, Nickel-Plated	8	6	Machined	60A

Tooling - Machined Contacts	
Part Number	Description
WA23	Heavy Duty Pneumatic Crimp Tool -Uses Universal Positioner Part No. WA23-101DA and Crimp Locator MFX-3961
WA23-2	Die Assembly -for CA-5E12 Heavy Duty Pneumatic Crimp Tool, Size 8
WA23-3	Die Assembly -for CA-5E12 Heavy Duty Pneumatic Crimp Tool, Size 6
WA23-10	Contact Locator, Size 6 and Size 8
96-978-22	Crimper and Dies -for Size 10mm <sup>2</sup> -185mm <sup>2</sup> Wires
AT114008	Contact Removal Tool, Plastic, Size 8, 8-10AWG