



CA3440

March 1993

Nanopower BiMOS Operational Amplifier

Features

- High Input Resistance..... $2T\Omega$ (Typ)
- Standby Power at $V+ = 5V$ 300nW (Typ)
- Supply Current, BW, Slew Rate Programmable Using External Resistor
- Input Current10pA (Typ)
- 5V to 15V Supply
- Output Drives Typical Bipolar Type Loads
- Low Cost 8 Pin Mini-DIP, TO-5 Can, SOIC

Description

The CA3440A and CA3440* are integrated circuit operational amplifiers that combine the advantages of MOS and bipolar transistors on a single monolithic chip.

The CA3440A and CA3440 BiMOS op amps feature gate protected PMOS transistors in the input circuit to provide very high input impedance, very low input currents (less than 10pA). These devices operate at total supply voltage from 5V to 15V and can be operated over the temperature range from -55°C to $+125^{\circ}\text{C}$. Their virtues are programmability and very low standby power consumption (300nW). These operational amplifiers are internally phase compensated to achieve stable operation in the unity gain follower configuration. Terminals are also provided for use in applications requiring input offset voltage nulling. The use of PMOS in the input stage results in common mode input voltage capability down to 0.5V below the negative supply terminals, an important attribute for single supply applications. The output stage uses MOS complementary source follower form which permits moderate load driving capability (10k Ω) at very low standby currents (50nA).

The CA3440A and CA3440 have the same 8 pin terminal pinout as the "741" and other industry standard op amps with two exceptions: terminals one and five must be connected to the negative supply or to a potentiometer if nulling is required. Terminal 8 must be programmed through an external resistor returned to the negative supply.

* Formerly Dev. Type No. TA10590.

Ordering Information

PART NUMBER	TEMPERATURE RANGE	PACKAGE
CA3440AE	-55°C to $+125^{\circ}\text{C}$	8 Lead Plastic DIP
CA3440AM	-55°C to $+125^{\circ}\text{C}$	8 Lead SOIC
CA3440AT	-55°C to $+125^{\circ}\text{C}$	8 Pin Can
CA3440E	-55°C to $+125^{\circ}\text{C}$	8 Lead Plastic DIP
CA3440M	-55°C to $+125^{\circ}\text{C}$	8 Lead SOIC
CA3440T	-55°C to $+125^{\circ}\text{C}$	8 Pin Can

Pinouts

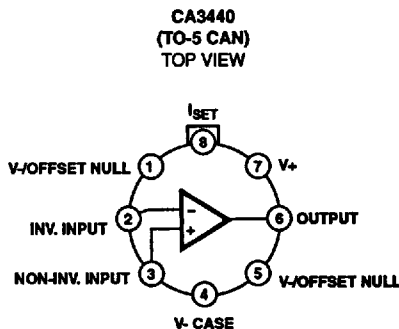
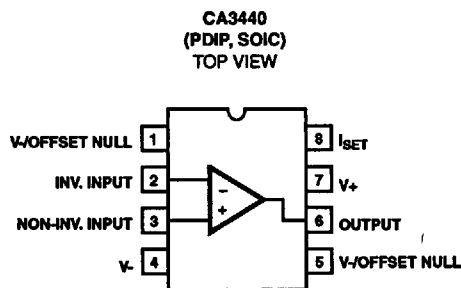

2
OPERATIONAL AMPLIFIERS

Specifications CA3440, CA3440A

Absolute Maximum Ratings

Supply Voltage (Between V+ and V- Terminals) 25V
 Differential Input Voltage 9V
 DC Input Voltage (V+ +8V) to (V- -0.5V)
 Input Current 1mA
 Junction Temperature +175°C
 Junction Temperature (Plastic Package) +150°C
 Output Short Circuit Duration (Note 1) Indefinite
 Lead Temperature (Soldering 10 Sec) +300°C

Operating Conditions

Operating Temperature Range -55°C to +125°C
 Storage Temperature Range -65°C to +150°C

CAUTION: Stresses above those listed in "Absolute Maximum Ratings" may cause permanent damage to the device. This is a stress only rating and operation of the device at these or any other conditions above those indicated in the operational sections of this specification is not implied.

Electrical Specifications Typical Values Intended Only for Design Guidance. V+ = +5V, V- = -5V; R_{SET} = 10MΩ, T_A = +25°C

PARAMETERS	SYMBOL	TEST CONDITIONS		CA3440A	CA3440	UNITS
Input Resistance	R _i			2	2	TΩ
Input Capacitance	C _i			3.5	3.5	pF
Output Resistance	R _O			450	450	Ω
Equivalent Input Noise Voltage	e _N	f = 1kHz	R _S = 100Ω	110	110	nV/√Hz
		f = 10kHz		110	110	nV/√Hz
Short-Circuit Current						
Source	IOM+			15	15	mA
To Opposite Supply						
Sink	IOM-			4.5	4.5	mA
Gain Bandwidth Product	f _T			63	63	kHz
Slew Rate	SR			0.03	0.03	V/μs
Transient Response		R _L = 10kΩ, C _L = 100pF				
Rise Time	t _r			5.6	5.6	μs
Overshoot	OS			10	10	%

NOTE:

1. Short circuit may be applied to ground or to either supply.

Electrical Specifications For Equipment Design. At $V_+ = +5V$, $V_- = -5V$, $R_{SET} = 10M\Omega$, $T_A = +25^\circ C$, Unless Otherwise Specified

PARAMETERS	SYMBOL	TEST CONDITIONS	LIMITS						UNITS
			CA3440A			CA3440			
			MIN	TYP	MAX	MIN	TYP	MAX	
Input Offset Voltage	$ V_{IO} $		-	2	5	-	5	10	mV
Input Offset Current	$ I_{IO} $		-	2.5	20	-	2.5	30	pA
Input Current	$ I_I $		-	10	40	-	10	50	pA
Large Signal Voltage Gain	AOL	$R_L = 10k\Omega$	10	100	-	10	100	-	kV/V
			80	100	-	80	100	-	dB
Common Mode Rejection Ratio	CMRR		-	100	320	-	100	320	$\mu V/V$
			70	80	-	70	80	-	dB
Common Mode Input Voltage Range	VICR +		+3.5	+3.7	-	+3.5	+3.7	-	V
	VICR -		-5.0	-5.3	-	-5.0	-5.3	-	V
Power Supply Rejection Ratio	PSRR		-	32	320	-	32	320	$\mu V/V$
			70	90	-	70	90	-	dB
Max Output Voltage	VOM +		+3	+3.2	-	+3	+3.2	-	V
	VOM -		-3	-3.2	-	-3	-3.2	-	V
Supply Current	I+		-	10	17	-	10	17	μA
Device Dissipation	P_D		-	100	170	-	100	170	μW
Input Offset Voltage Temp. Drift	$\Delta V_{IO}/\Delta T$		-	4	-	-	4	-	$\mu V/^\circ C$

Schematic Diagram

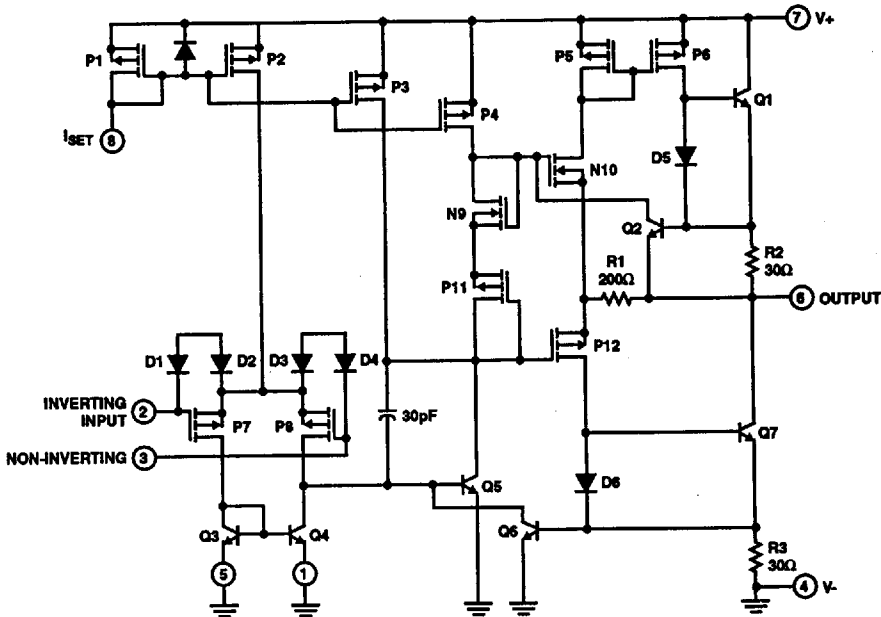

2
OPERATIONAL AMPLIFIERS

Typical Performance Curves

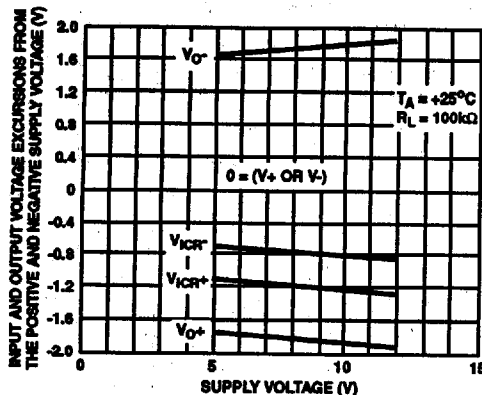

FIGURE 1. OUTPUT VOLTAGE SWING AND COMMON MODE INPUT VOLTAGE RANGE vs SUPPLY VOLTAGE

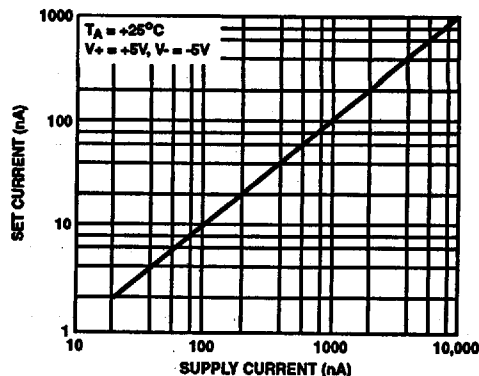

FIGURE 2. SET CURRENT vs SUPPLY CURRENT

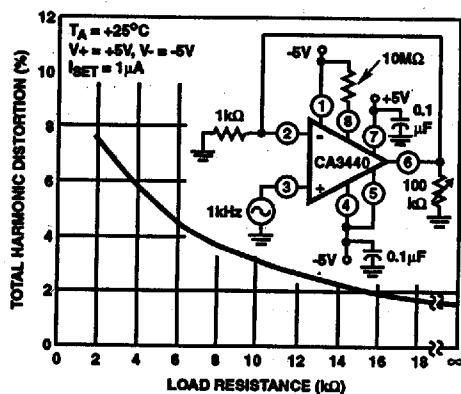

FIGURE 3. TOTAL HARMONIC DISTORTION vs LOAD RESISTANCE

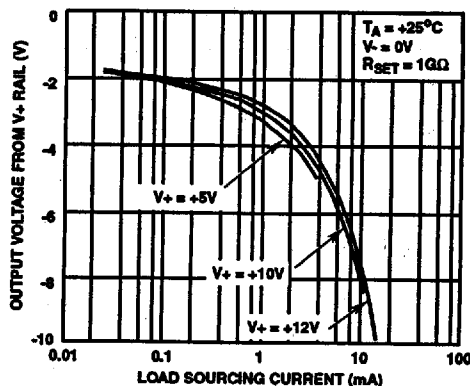

FIGURE 4. OUTPUT VOLTAGE vs SOURCING LOAD CURRENT

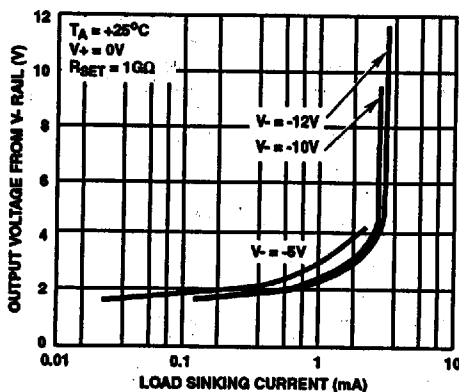

FIGURE 5. OUTPUT VOLTAGE vs SINKING LOAD CURRENT

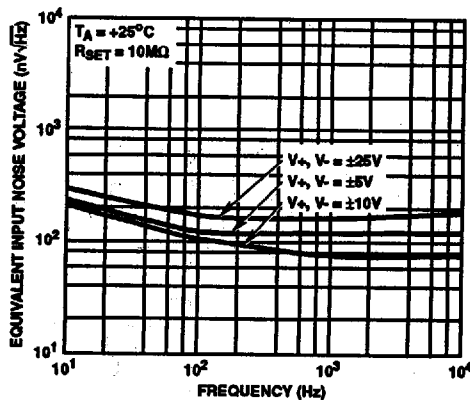

FIGURE 6. INPUT NOISE VOLTAGE vs FREQUENCY

Typical Performance Curves (Continued)

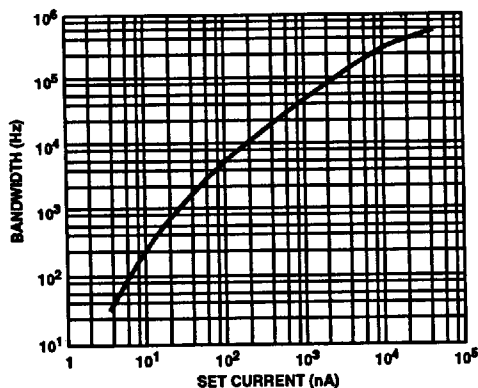

FIGURE 7. BANDWIDTH vs SET CURRENT

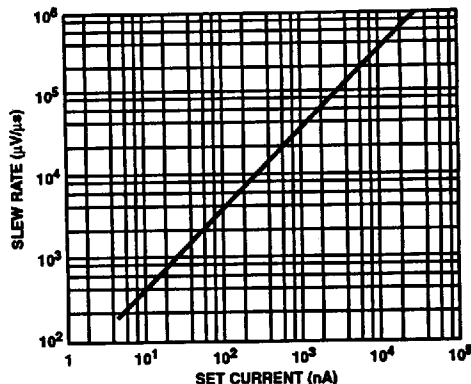

FIGURE 8. SLEW RATE vs SET CURRENT

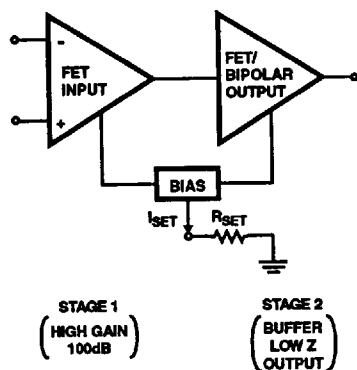

FIGURE 9. NANOPOWER OP AMP (SUPPLY CURRENT PROGRAMMABLE USING R_{SET}), 1pA TYPICAL INPUT BIAS CURRENT, 4.0V TO 15V SUPPLY

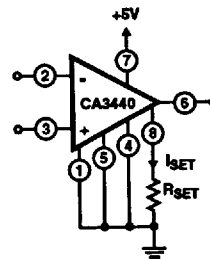

FIGURE 10. NANOPOWER OP AMP (USABLE STANDBY POWER vs PROGRAMMING RESISTOR R_{SET})

As R_{SET} is increased, I_{SET} and the standby power decrease while the BW/SR also decreases.

Operating at a +5V single supply, the CA3440 exhibits the following characteristics:

R_{SET}	STANDBY POWER	BW	SR
1M Ω	250 μ W	164kHz	0.17V/ μ s
10M Ω	25 μ W	27kHz	0.017V/ μ s
100M Ω	2.5 μ W	2.6kHz	0.0017V/ μ s
1G Ω	250nW	78kHz	0.00017V/ μ s

The CA3440 is pin compatible with the 741 except that pins 1 and 5 (typical negative nulling pins) must be connected either directly to pin 4 or to a negative nulling potentiometer. In addition, pin 8, the I_{SET} terminal, must be returned to either ground or -V via R_{SET}

2
OPERATIONAL AMPLIFIERS

Applications Circuits

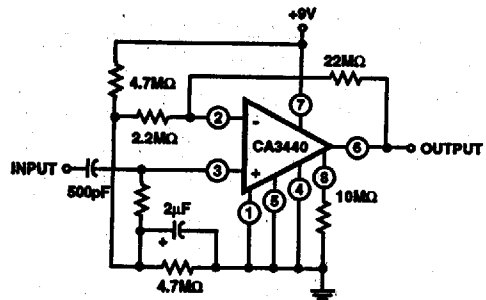

$R_{IN} > 20M\Omega$
Standby Power = $90\mu W$
Gain = 20dB
BW: 20Hz to 3kHz
SR = $0.016V/\mu s$

FIGURE 11. HIGH INPUT IMPEDANCE AMPLIFIER

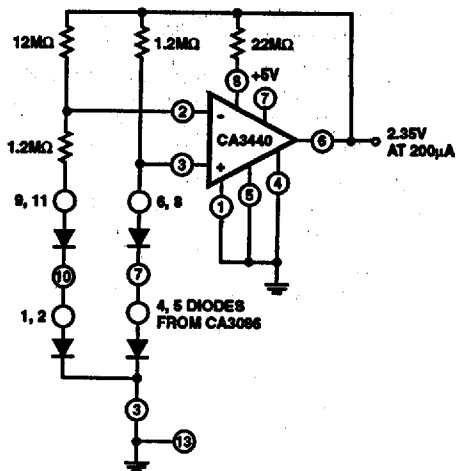

FIGURE 12. MICROPOWER BANDGAP REFERENCE