

LBSS4250Y3T1G

S-LBSS4250Y3T1G

NPN 2.0A 50V Middle Power Transistor

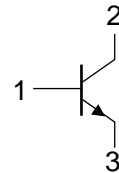
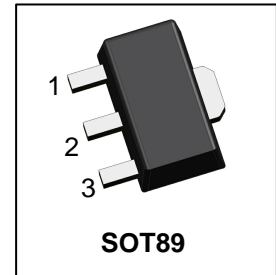

1. FEATURES

- Suitable for Middle Power Driver
- Complementary PNP Types
- Low VCE(sat)
- We declare that the material of product compliance with RoHS requirements and Halogen Free.
- S- prefix for automotive and other applications requiring unique site and control change requirements; AEC-Q101 qualified and PPAP capable.

2. APPLICATIONS

- Motor driver , LED driver
- Power supply

3. DEVICE MARKING AND ORDERING INFORMATION

Device	Marking	Shipping
LBSS4250Y3T1G	G	1000/Tape&Reel

4. MAXIMUM RATINGS(Ta = 25°C)

Parameter	Symbol	Limits	Unit
Collector–Emitter Voltage	VCEO	50	V
Collector–Base Voltage	VCBO	50	V
Emitter–Base Voltage	VEBO	6	V
Collector Current	IC	2	A
Pulsed Collector Current	ICP	4	A

5. THERMAL CHARACTERISTICS

Parameter	Symbol	Limits	Unit
Total Device Dissipation, FR-4 Board (Note 1) @ TA = 25°C Derate above 25°C	PD	550 4.4	mW mW/°C
Thermal Resistance, Junction–to–Ambient	θJA	225	°C/W
Junction and Storage temperature	TJ,Tstg	-55~+150	°C

1.PCB Size:30.0mm×25.0mm×1.6mm,FR-4 Board;

6. ELECTRICAL CHARACTERISTICS (Ta= 25°C)

Characteristic	Symbol	Min.	Typ.	Max.	Unit
Collector-emitter breakdown voltage (IC = 1mA)	BVCEO	50	-	-	V
Collector-base breakdown voltage (IC = 100μA)	BVCBO	50	-	-	V
Emitter-base breakdown voltage (IE = 100μA)	BVEBO	6	-	-	V
Collector Cutoff Current (VCB = 50 V)	ICBO	-	-	1	μA
Emitter Cut-off Current (VEB =4V, IC =0)	IEBO	-	-	1	μA
DC Current Gain (VCE = 2 V, IC = 50mA)	HFE	180	-	450	
Collector–Emitter Saturation Voltage (IC = 700mA, IB = 35mA)	VCE(sat)	-	0.13	0.35	V
Transition Frequency (VCE = 10V, IE = -300mA, f = 100 MHz)	fT	-	360	-	MHz
Output capacitance (VCB = 10V, IE = 0A, f = 1 MHz)	Cob	-	12	-	pF

7.ELECTRICAL CHARACTERISTICS CURVES

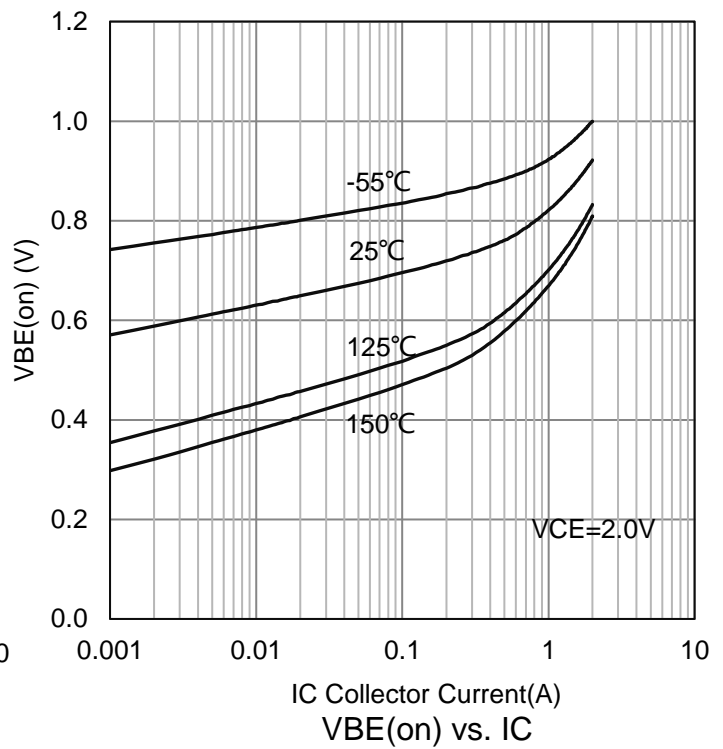
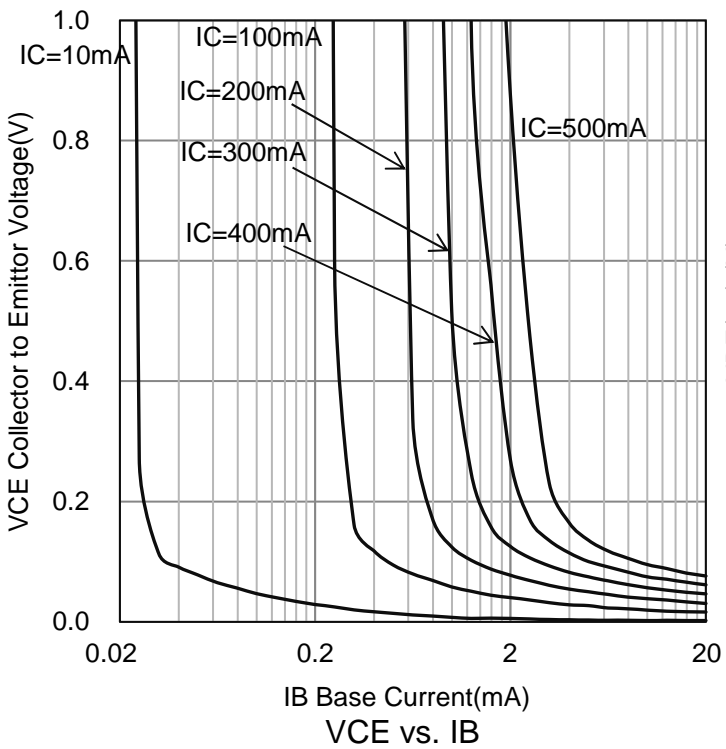
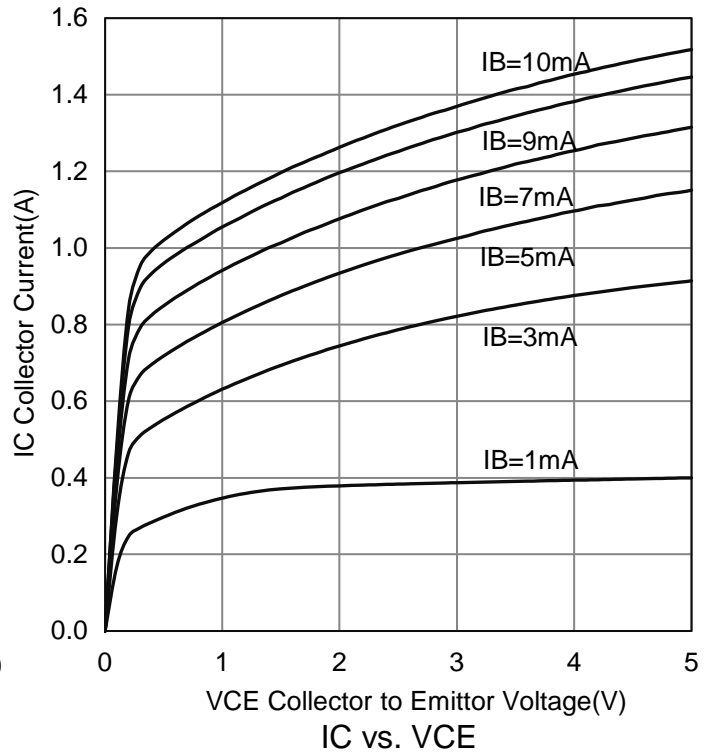
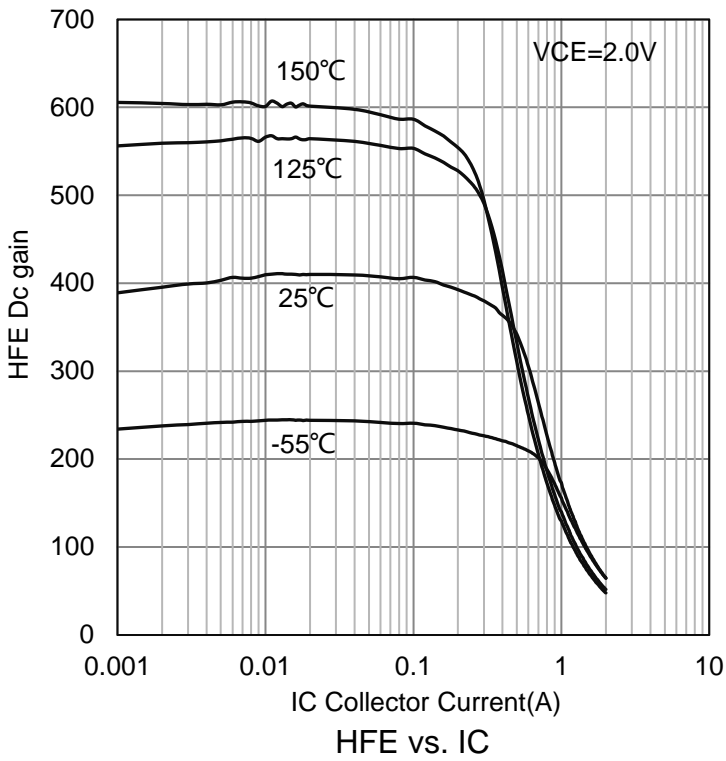

7.ELECTRICAL CHARACTERISTICS CURVES(Con.)

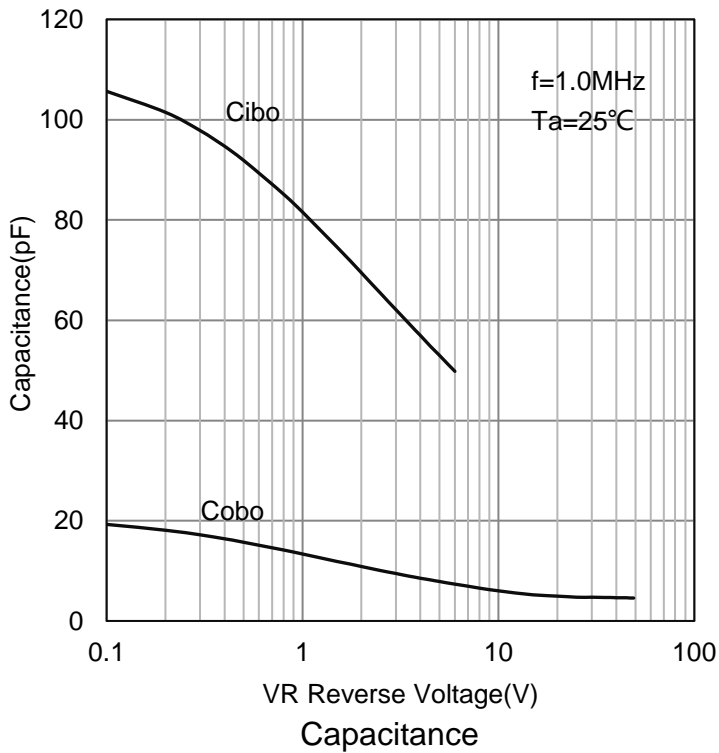
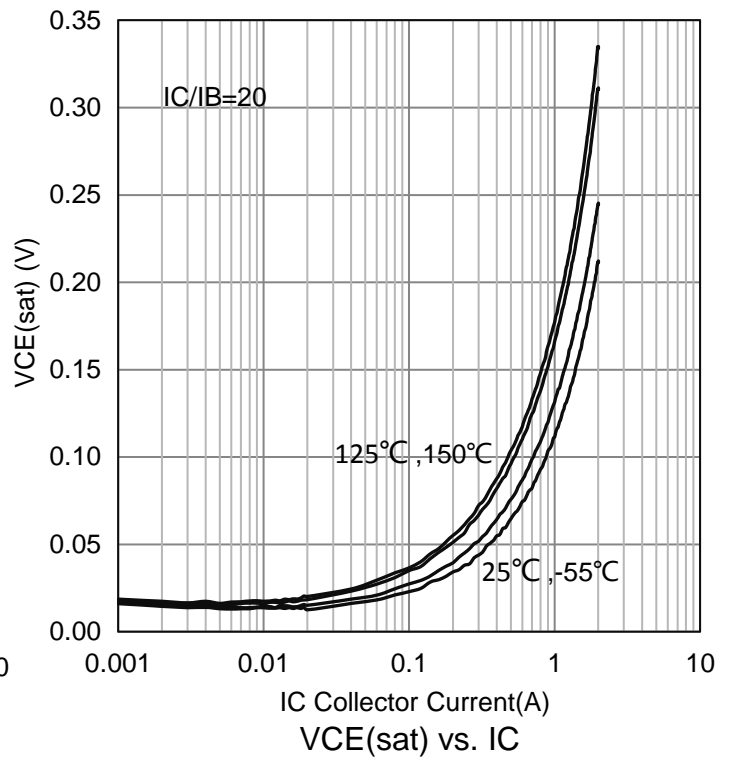
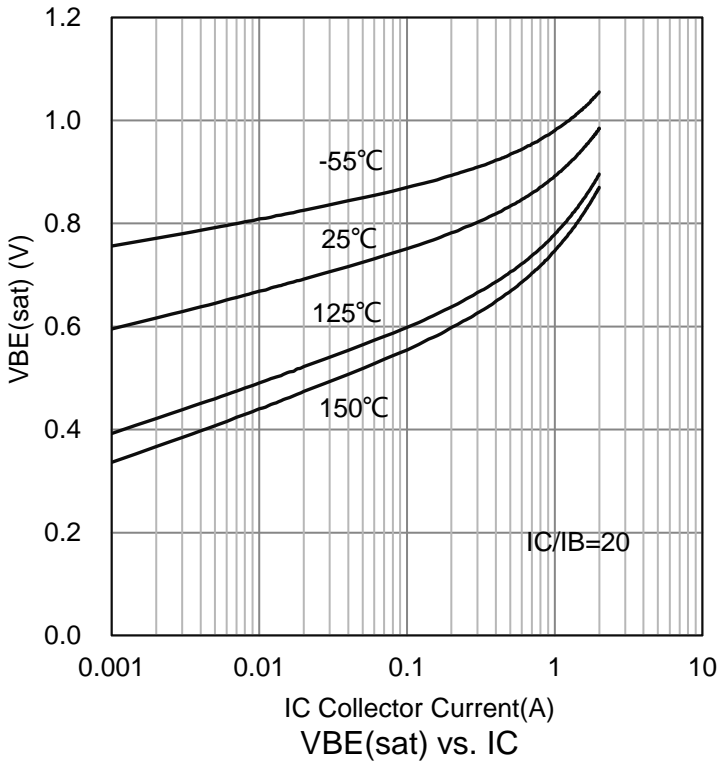

8.OUTLINE AND DIMENSIONS

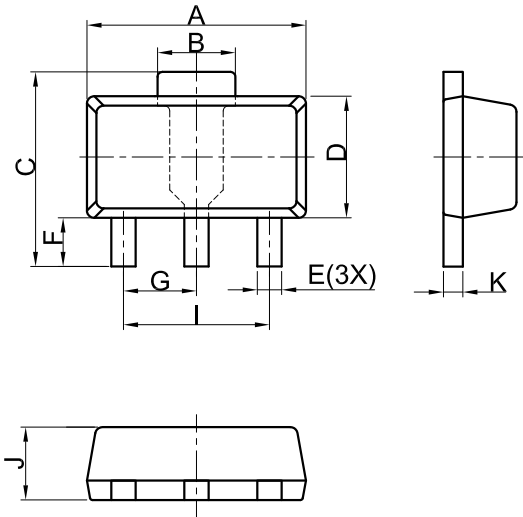

SOT89			
DIM	MIN	NOR	MAX
A	4.30	4.50	4.70
B	1.40	1.60	1.80
C	3.90	4.00	4.25
D	2.30	2.50	2.70
E	0.40	0.50	0.58
F	0.90	1.00	1.20
G	1.50 BSC		
I	3.00 BSC		
J	1.40	1.50	1.60
K	0.34	0.40	0.50
All Dimensions in mm			

GENERAL NOTES

1. Top package surface finish Ra0.4±0.2um
2. Bottom package surface finish Ra0.7±0.2um
3. Side package surface finish Ra0.4±0.2um
4. Protrusion or Gate Burrs shall not exceed 0.10mm per side.

9.SOLDERING FOOTPRINT

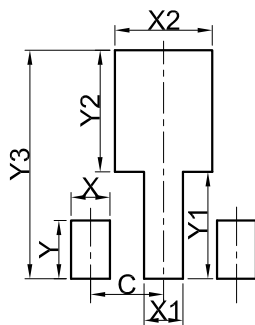

SOT89	
DIM	(mm)
X	0.80
Y	1.20
X1	0.80
Y1	2.20
X2	2.00
Y2	2.50
C	1.50
Y3	4.70