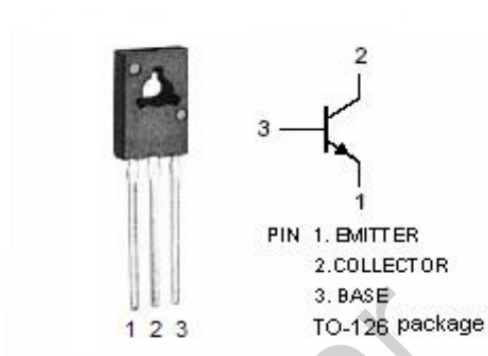

DESCRIPTION

- Collector–Emitter Sustaining Voltage–
: $V_{CEO(SUS)} = 300\text{ V(Min)}$
- DC Current Gain–
: $h_{FE} = 100(\text{Min}) @ I_C = 50\text{mA}$
- Low Collector Saturation Voltage–
: $V_{CE(sat)} = 1.0\text{V(Max.)} @ I_C = 50\text{mA}$
- Complement to the PNP MJE350

APPLICATIONS

- Designed for high voltage and general purpose applications.

ABSOLUTE MAXIMUM RATINGS($T_a=25^\circ\text{C}$)

SYMBOL	PARAMETER	VALUE	UNIT
V_{CBO}	Collector-Base Voltage	300	V
V_{CEO}	Collector-Emitter Voltage	300	V
V_{EBO}	Emitter-Base Voltage	3	V
I_C	Collector Current-Continuous	0.5	A
P_C	Collector Power Dissipation $T_C=25^\circ\text{C}$	20	W
T_j	Junction Temperature	150	$^\circ\text{C}$
T_{stg}	Storage Temperature Range	-65~150	$^\circ\text{C}$

THERMAL CHARACTERISTICS

SYMBOL	PARAMETER	MAX	UNIT
$R_{th\ j-c}$	Thermal Resistance, Junction to Case	6.25	$^\circ\text{C/W}$

ELECTRICAL CHARACTERISTICS
 $T_C = 25^\circ\text{C}$ unless otherwise specified

SYMBOL	PARAMETER	CONDITIONS	MIN	MAX	UNIT
$V_{CEO(SUS)}$	Collector-Emitter Sustaining Voltage	$I_C = 1.0\text{mA}; I_B = 0$	300		V
$V_{(BR)CBO}$	Collector-Base Breakdown Voltage	$I_C = 1.0\text{mA}; I_E = 0$	300		V
$V_{(BR)EBO}$	Emitter-Base Breakdown Voltage	$I_E = 1.0\text{mA}; I_C = 0$	3		V
$V_{CE(sat)}$	Collector-Emitter Saturation Voltage	$I_C = 50\text{mA}; I_B = 5\text{mA}$		1.0	V
I_{CBO}	Collector Cutoff Current	$V_{CB} = 300\text{V}; I_E = 0$		0.1	mA
I_{EBO}	Emitter Cutoff Current	$V_{EB} = 3\text{V}; I_C = 0$		0.1	mA
h_{FE}	DC Current Gain	$I_C = 50\text{mA}; V_{CE} = 10\text{V}$	100	240	

Package Information

TO-126

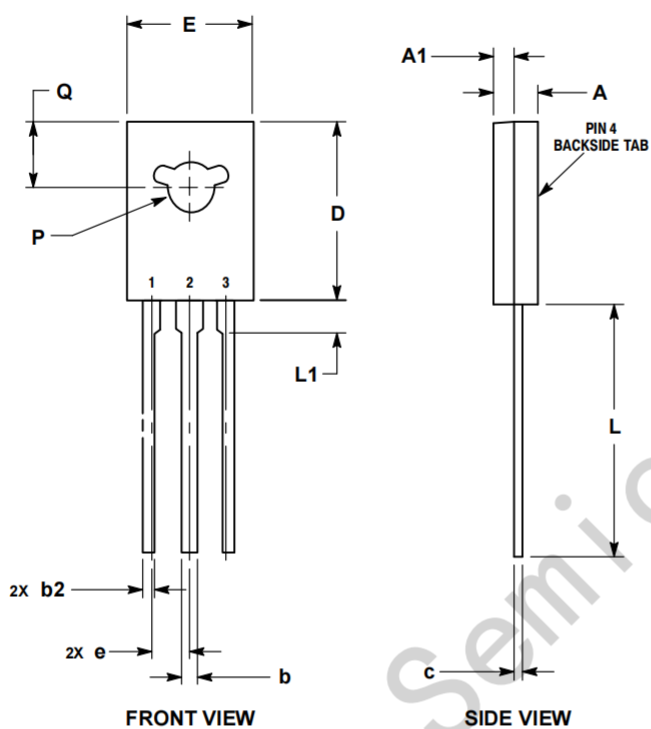

- NOTES:
1. DIMENSIONING AND TOLERANCING PER ASME Y14.5M, 1994.
 2. CONTROLLING DIMENSION: MILLIMETERS.
 3. NUMBER AND SHAPE OF LUGS OPTIONAL.

DIM	MILLIMETERS	
	MIN	MAX
A	2.40	3.00
A1	1.00	1.50
b	0.60	0.90
b2	0.51	0.88
c	0.39	0.63
D	10.60	11.10
E	7.40	7.80
e	2.04	2.54
L	14.50	16.63
L1	1.27	2.54
P	2.90	3.30
Q	3.80	4.20

STYLE 1:
 PIN 1. EMITTER
 2, 4. COLLECTOR
 3. BASE

