

TB5128: H;

CLOCK-in and Serial controlled Bipolar Stepping Motor Driver

1. Outline

The TB5128FTG is a two-phase bipolar stepping motor driver using a PWM chopper. The clock in decoder is built in. Fabricated with the BiCD process, output rating is 50 V/5.0 A (Motor supply voltage = 44 V).

2. Features

- BiCD process integrated monolithic IC.
 - Capable of controlling 1 bipolar stepping motor.
 - PWM controlled constant-current drive
 - Low on-resistance (High + Low side = 0.25 Ω (typ.)) MOSFET output stage.
 - Allows full, half, quarter, 1/8, 1/16, 1/32, 1/64, 1/128 step operation.
 - High efficiency motor current control mechanism (ADMD: Advanced Dynamic Mixed Decay)
 - Built-in Sense resistor less current control architecture (ACDS: Advanced Current Detection System)
 - High voltage and current (For specification, please refer to absolute maximum ratings and operation ranges)
 - Multi error detect functions (Thermal shutdown (TSD), Over current (ISD), Power-on-reset (POR), motor load open (OPD)).
 - Error detection (TSD/ISD/OPD) flag output function
 - Built-in VCC regulator for internal circuit
 - Chopping frequency of a motor can be adjusted by external resistance and capacitor.
 - Small package with thermal pad
- TB5128FTG: P-VQFN48-0707-0.50-004

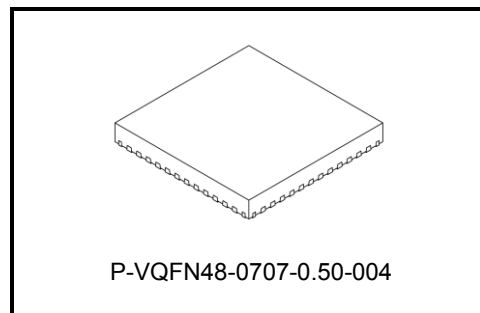

Weight: 0.14g (typ.)

Note: Please be careful about thermal conditions during using.

3. Pin Assignment

Pin assignment in CLK mode (IF_SEL pin = L) is shown in below figure.

<TOP View>

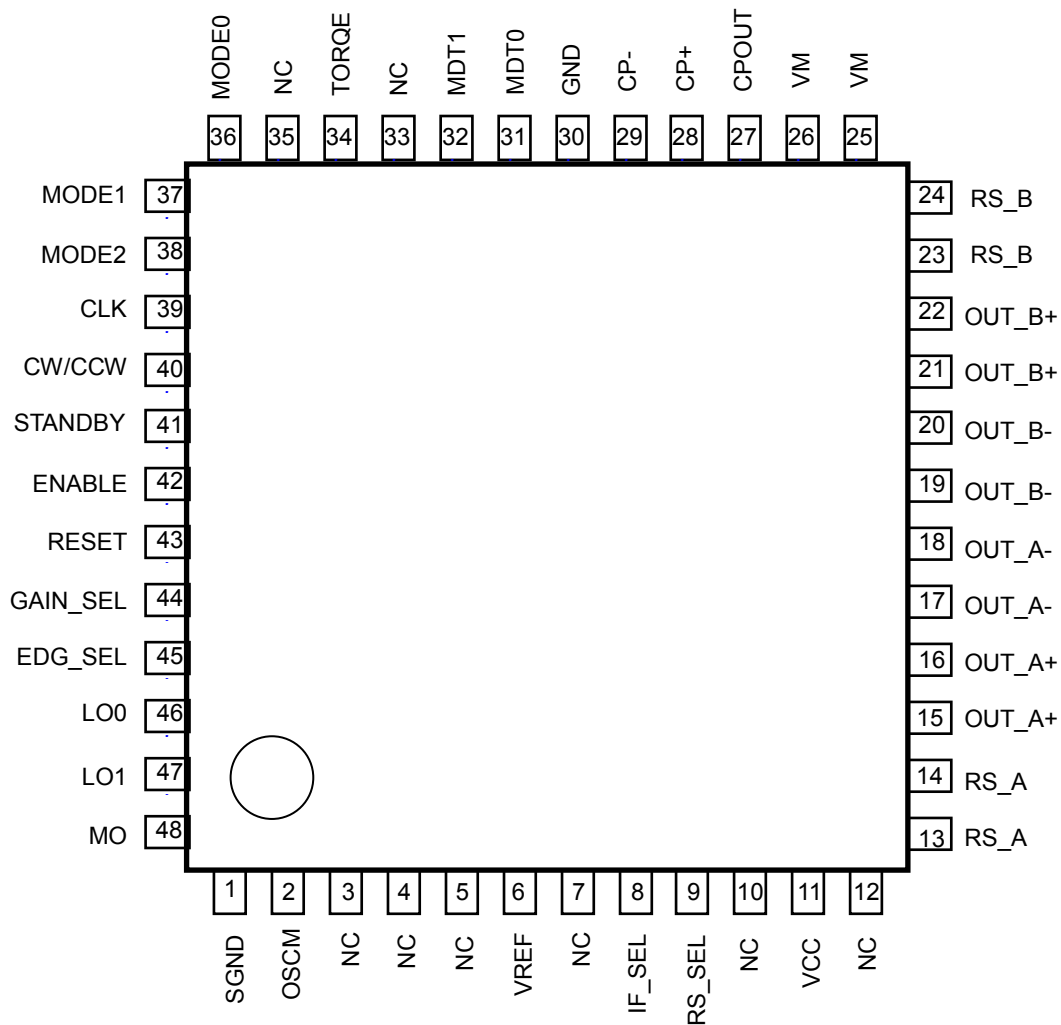

Note: Please solder the corner pad and the rear thermal pad of the QFN package, to the GND pattern of the PCB.

4. Pin Description

Pin No.	Symbol		Description
	CLK mode	Serial mode	
1	SGND	SGND	Logic ground pin
2	OSCM	OSCM	Internal oscillator frequency monitor and setting pin
3	NC	NC	NC Pin
4	NC	NC	NC Pin
5	NC	NC	NC Pin
6	VREF	VREF	Current threshold reference pin
7	NC	NC	NC Pin
8	IF_SEL	IF_SEL	Interface select pin
9	RS_SEL	NC	RS mode select pin
10	NC	NC	NC pin
11	VCC	VCC	Internal regulator voltage monitor pin
12	NC	NC	NC pin
13	RS_A (Note2)	RS_A (Note2)	Ach current sense resistor connected pin / Ach motor power ground pin
14	RS_A (Note2)	RS_A (Note2)	Ach current sense resistor connected pin / Ach motor power ground pin
15	OUT_A+ (Note2)	OUT_A+ (Note2)	Ach motor output(+) pin
16	OUT_A+ (Note2)	OUT_A+ (Note2)	Ach motor output(+) pin
17	OUT_A- (Note2)	OUT_A- (Note2)	Ach motor output(-) pin
18	OUT_A- (Note2)	OUT_A- (Note2)	Ach motor output(-) pin
19	OUT_B- (Note2)	OUT_B- (Note2)	Bch motor output(-) pin
20	OUT_B- (Note2)	OUT_B- (Note2)	Bch motor output(-) pin
21	OUT_B+ (Note2)	OUT_B+ (Note2)	Bch motor output(+) pin
22	OUT_B+ (Note2)	OUT_B+ (Note2)	Bch motor output(+) pin
23	RS_B (Note2)	RS_B (Note2)	Bch current sense resistor connected pin / Bch motor power ground pin
24	RS_B (Note2)	RS_B (Note2)	Bch current sense resistor connected pin / Bch motor power ground pin
25	VM (Note2)	VM (Note2)	Motor power supply input pin
26	VM (Note2)	VM (Note2)	Motor power supply input pin
27	CPOUT	CPOUT	Pin for Charge pump
28	CP+	CP+	Pin for Charge pump
29	CP-	CP-	Pin for Charge pump
30	GND	GND	GND
31	MDT0	NC	Mixed Decay/ADMD setting pin
32	MDT1	NC	Mixed Decay/ADMD setting pin
33	NC	NC	NC pin
34	TORQE	NC	Torque setting pin
35	NC	NC	NC pin
36	MODE0	NC	Excitation setting pin No.0
37	MODE1	NC	Excitation setting pin No.1
38	MODE2	NC	Excitation setting pin No.2
39	CLK	CLK	Step clock input pin / Serial clock input pin
40	CW/CCW	DATA	Current direction setup pin / Data input pin in serial interface
41	STANDBY	STANDBY	Standby pin
42	ENABLE	LATCH	Motor output ON/OFF pin / Latch Enable input pin
43	RESET	BANK_EN	Electrical angle initialize pin / BANK select pin

Pin No.	Symbol		Description
	CLK mode	Serial mode	
44	GAIN_SEL	NC	Vref Gain setting pin
45	EDG_SEL	NC	CLK edge setting pin
46	LO0	LO0	Error detection flag output pin No.0
47	LO1	LO1	Error detection flag output pin No.1
48	MO	NC	Electrical angle monitor pin

Note1: This pin should be opened or connected to Ground.

Note2: The same name pins should be connected with PCB pattern each other.

5. Block Diagram

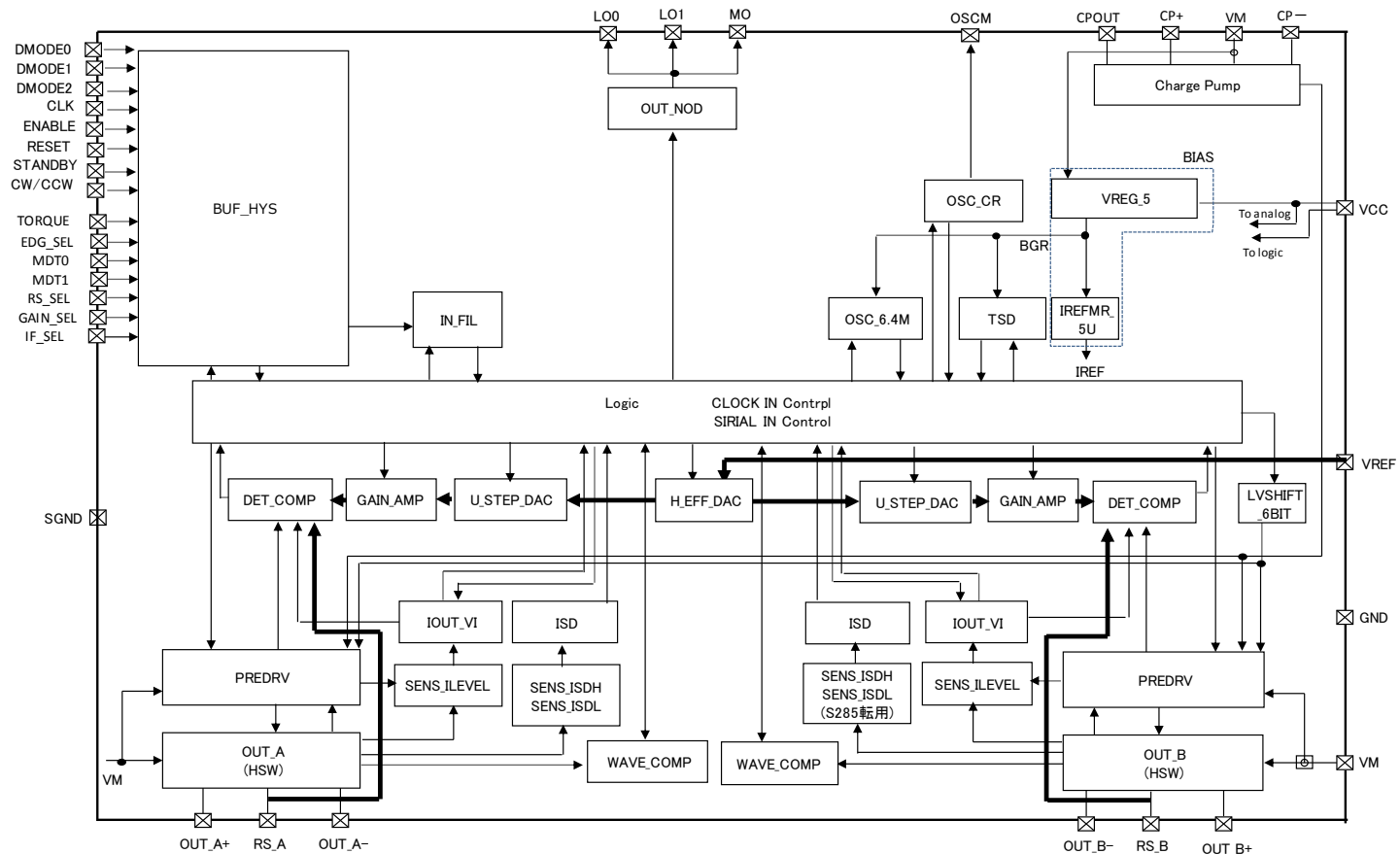

Note: Some of the functional blocks, circuits, or constants in the block diagram may be omitted or simplified for explanatory purpose.

Note: All the grounding wires of the TB5128 should run on the solder mask on the PCB and be externally terminated at only one point. Also, a grounding method should be considered for efficient heat dissipation. Careful attention should be paid to the layout of the output, VM and GND traces, to avoid short circuits across output pins or to the power supply or ground. If such a short circuit occurs, the device may be permanently damaged. Also, the utmost care should be taken for pattern designing and implementation of the device since it has power supply pins (VM, RS line, OUT line, and GND) through which a particularly large current may run. If these pins are wired incorrectly, an operation error may occur or the device may be destroyed. The logic input pins must also be wired correctly. Otherwise, the device may be damaged owing to a current running through the IC that is larger than the specified current. Careful attention should be paid to design patterns and mountings.

6. INPUT/OUTPUT Equivalent Circuit

Pin name	IN/OUT signal	Equivalent circuit
MODE0, 1, 2 CLK ENABLE RESET CW/CCW TORQE EDG_SEL MDT0, 1 RS_SEL GAIN_SEL IF_SEL STANDBY	Digital Input (VIH/VIL) VIH: 2.0 V (min) to 5.5 V (max) VIL: 0 V (min) to 0.8 V (max)	
LO0, LO1 MO	Digital Output (VOH/VOL) (Pullup resistance: 10 k to 100 kΩ)	
VCC VREF	VCC voltage range 4.75 V (min) 5.0 V (typ.) 5.25 V (max) VREF voltage range 0 V to 3.6 V	
OSCM	OSCM frequency setting range 0.64 MHz (min) 1.12 MHz (typ.) 2.4 MHz (max)	
OUT_A+ OUT_A- OUT_B+ OUT_B- RS_A RS_B	VM power supply voltage range 6.5 V (min) to 44 V (max) OUTPUT pin voltage 11.2 V (min) to 48.7 V (max)	

Pin name	IN/OUT signal	Equivalent circuit
CPOUT CP+ CP-	VM power supply voltage range 6.5 V (min) to 44 V (max) OUTPUT pin voltage 11.2 V (min) to 48.7 V (max)	

Note: The equivalent circuit diagrams may be simplified for explanatory purposes.

7. IF Select Function

IF can be selected from CLK type or serial type.

IF_SEL pin input	Function
L	CLK mode
H	Serial mode

8. Functional Description 1 (for CLK mode when IF_SEL pin = L)

8.1. CLK Function

Each up-edge of the CLK signal will shift the motor's electrical angle per step.

When EDG_SEL pin = L (Single Edge)

CLK pin input	Function
Up-edge	Shifts the electrical angle per step.
Down-edge	(State of the electrical angle does not change.)

When EDG_SEL pin = H (Double Edge)

CLK pin input	Function
Up-edge	Shifts the electrical angle per step.
Down-edge	Shifts the electrical angle per step.

8.2. ENABLE Function

The ENABLE pin controls the ON and OFF of the stepping motor outputs. Motor operation starts and stops by setting H and L to the ENABLE pin. (When ENABLE pin is set to L (OFF), all of the MOSFETs turn off and become high impedance (hereafter, Hi-Z).)

Setting the ENABLE pin to L, and avoiding the motor to operate during VM power-on and power-off (i.e., outside of the operating voltage range) is recommended. Then, switch the ENABLE pin to H after the VM reaches the target voltage and becomes stable.

ENABLE pin input	Function
L	OFF (High impedance mode, later omitted Hi-Z mode later)
H	ON (Normal operation mode)

8.3. CW/CCW Function and the Output Pin Function (Output logic at the time of a charge start)

The CW/CCW pin controls the rotation direction of the motor. When set to H, the current of OUT_A is output first, with a phase difference of 90°. When set to L, the current of OUT_B is output first with a phase difference of 90°.

CW/CCW pin input	OUT_x+	OUT_x-
L: Counter clockwise operation (CCW)	L	H
H: Clockwise operation (CW)	H	L

Note: x = A or B

8.4. Step Resolution Select Function

MODE 0, MODE1, and MODE2 pins control the step resolution. Pin levels of MODE0, MODE1, and MODE2 can be switched during operation. The following step current depends on the electrical angle.

MODE2 pin input	MODE1 pin input	MODE0 pin input	Function
L	L	L	Full step resolution
L	L	H	Half step resolution
L	H	L	Quarter step resolution
L	H	H	1/8 step resolution
H	L	L	1/16 step resolution
H	L	H	1/32 step resolution
H	H	L	1/64 step resolution
H	H	H	1/128 step resolution

8.5. Timing Chart of Step Resolution Setting and Initial Angel

[Full step resolution]

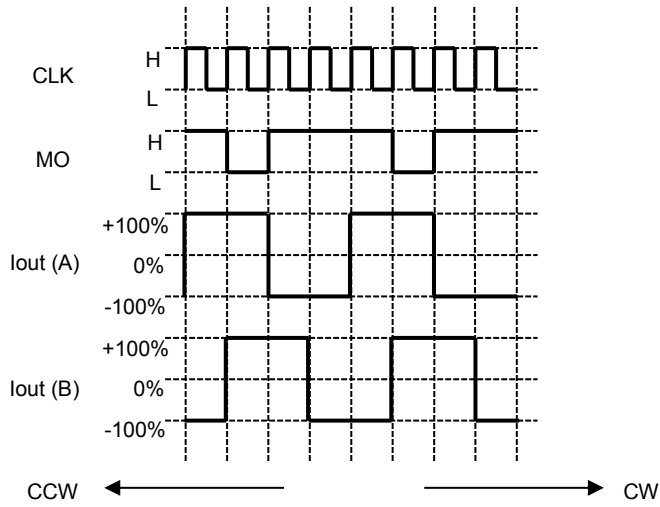

[Half step resolution]

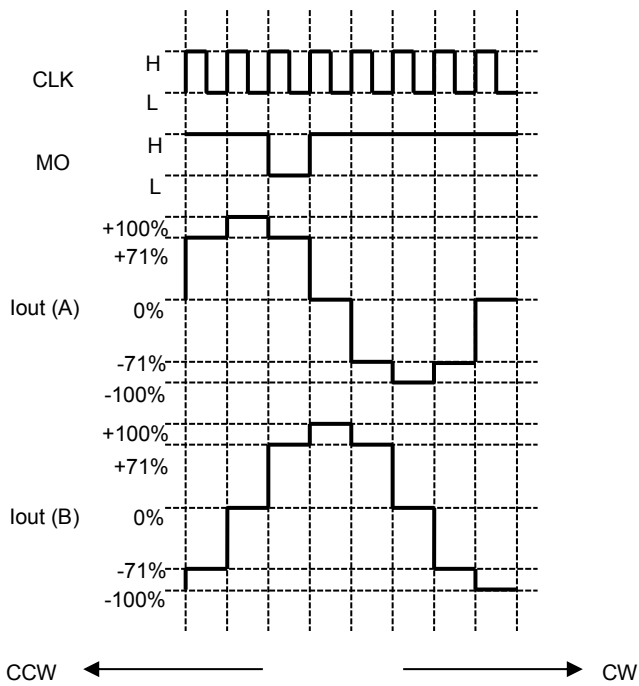

Note: MO signal is shown in the above timing chart when MO pin is connected with a pull-up resistor to VCC.

Note: Timing charts may be simplified for explanatory purpose.

[Quarter step resolution]

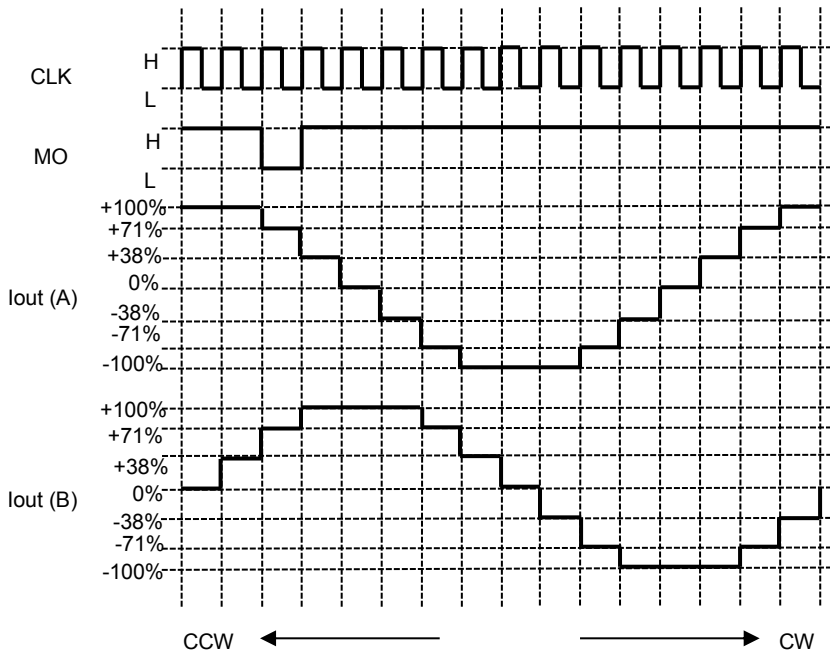

Note: MO signal is shown in the above timing chart when MO pin is connected with a pull-up resistor to VCC.
Note: Timing charts may be simplified for explanatory purpose.

[1/8 step resolution]

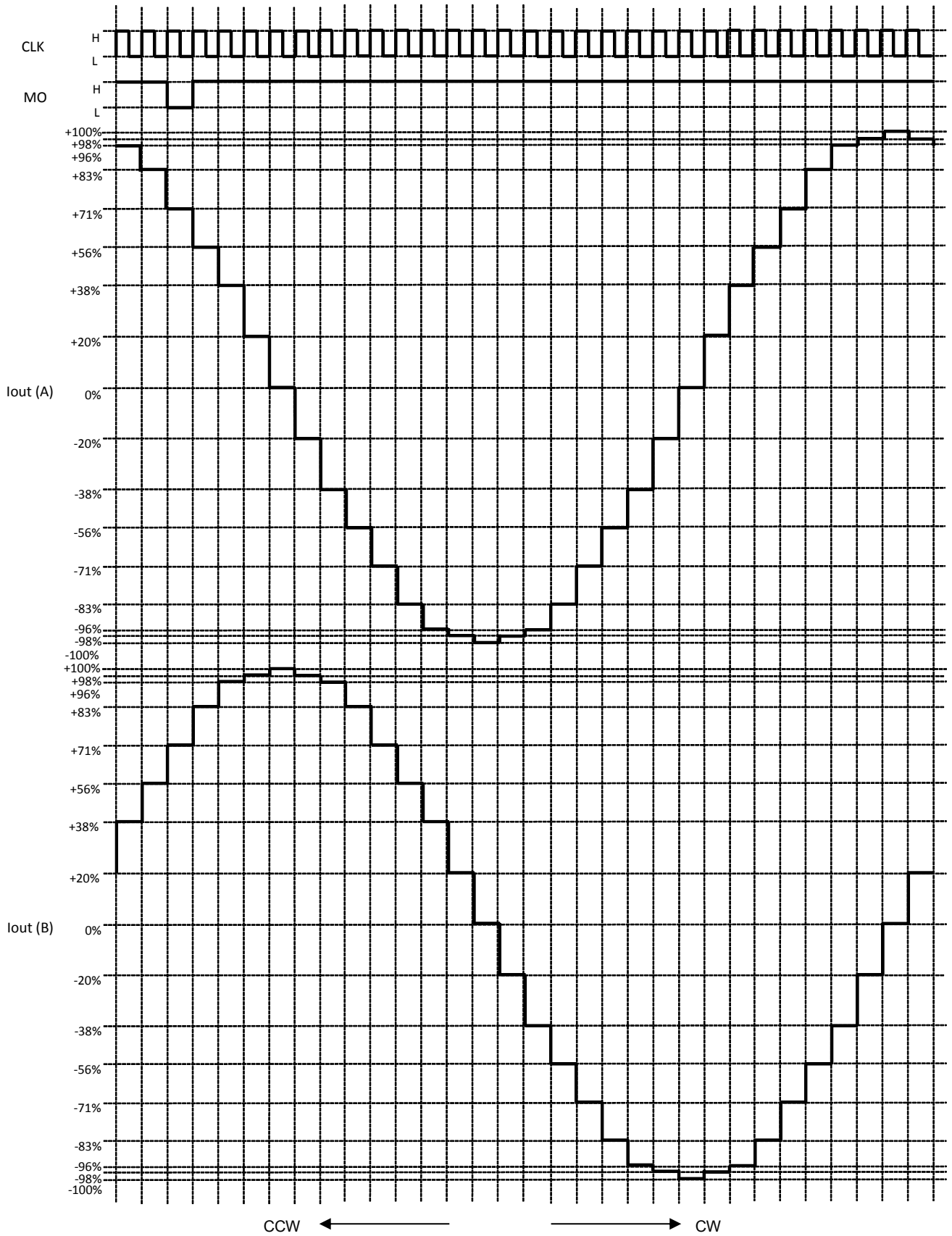

Note: MO signal is shown in the above timing chart when MO pin is connected with a pull-up resistor to VCC.

Note: Timing charts may be simplified for explanatory purpose.

[1/16 step resolution]

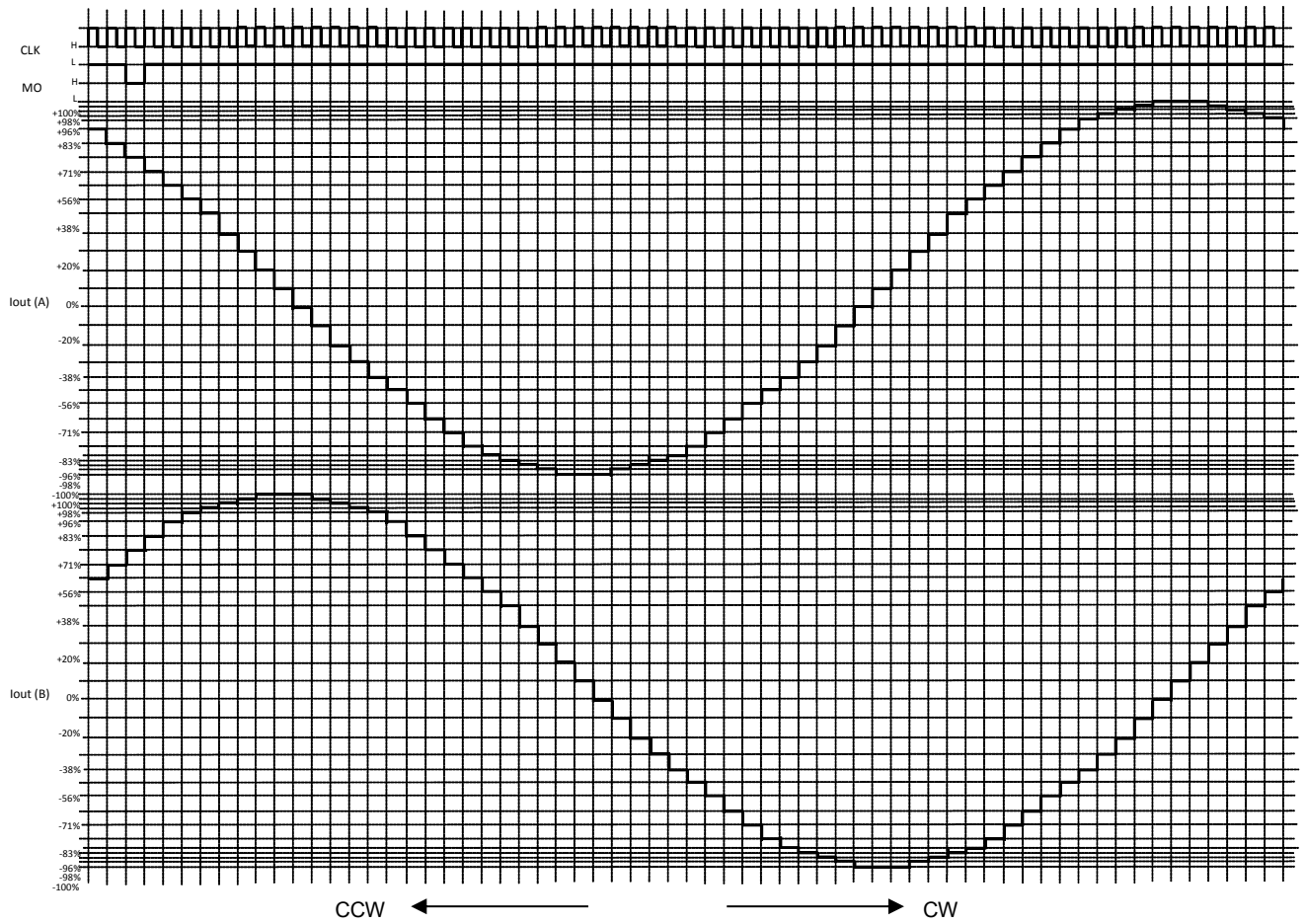

Note: MO signal is shown in the above timing chart when MO pin is connected with a pull-up resistor to VCC.
Note: Timing charts may be simplified for explanatory purpose.

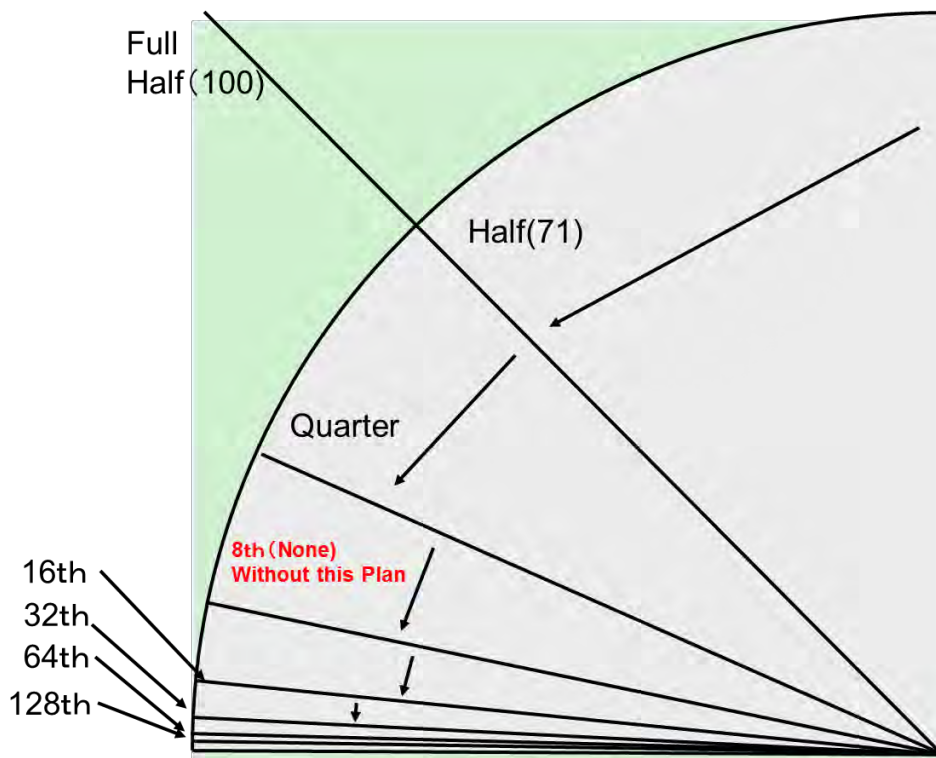

8.6. Step Setting and Current Percentage

Current (%)	Full	Half	Quarter	1/8	1/16	1/32	1/64	1/128
100%	Available	Available	Available	Available	Available	Available	Available	Available
99%					Available	Available	Available	Available
98%				Available	Available	Available	Available	Available
97%					Available	Available	Available	Available
96%				Available	Available	Available	Available	Available
95%							Available	Available
94%						Available	Available	Available
93%							Available	Available
92%						Available	Available	Available
91%							Available	Available
90%					Available	Available	Available	Available
89%							Available	Available
88%						Available	Available	Available
87%							Available	Available
86%						Available	Available	Available
85%								Available
84%							Available	Available
83%				Available	Available	Available	Available	Available
82%							Available	Available
81%								Available
80%						Available	Available	Available
79%							Available	Available
78%								Available
77%					Available	Available	Available	Available
76%							Available	Available
75%								Available
74%						Available	Available	Available
73%								Available
72%							Available	Available
71%		Available	Available	Available	Available	Available	Available	Available
70%								Available
69%							Available	Available
68%								Available
67%						Available	Available	Available
66%								Available
65%							Available	Available
64%								Available
63%					Available	Available	Available	Available
62%							Available	Available
61%								Available
60%						Available	Available	Available
59%								Available
58%							Available	Available
57%								Available
56%				Available	Available	Available	Available	Available
55%								Available
53%							Available	Available
52%						Available		Available
51%							Available	Available
50%								Available
49%							Available	Available
48%								Available
47%					Available	Available	Available	Available
46%								Available

Current (%)	Full	Half	Quarter	1/8	1/16	1/32	1/64	1/128
45%							Available	Available
44%								Available
43%						Available	Available	Available
42%								Available
41%							Available	Available
39%								Available
38%			Available	Available	Available	Available	Available	Available
37%								Available
36%							Available	Available
35%								Available
34%						Available	Available	Available
33%								Available
31%							Available	Available
30%								Available
29%					Available	Available	Available	Available
28%								Available
27%							Available	Available
25%						Available		Available
24%							Available	Available
23%								Available
22%							Available	Available
21%								Available
20%				Available	Available	Available	Available	Available
18%								Available
17%							Available	Available
16%								Available
15%						Available	Available	Available
13%								Available
12%							Available	Available
11%								Available
10%					Available	Available	Available	Available
9%								Available
7%							Available	Available
6%								Available
5%						Available	Available	Available
4%								Available
2%							Available	Available
1%								Available
0%		Available	Available	Available	Available	Available	Available	Available

8.7. Step Resolution and Set Current

STEP	1/128		1/64		1/32		1/16		1/8		1/4		1/2		Full	
	Ach (%)	Bch (%)	Ach (%)	Bch (%)	Ach (%)	Bch (%)	Ach (%)	Bch (%)	Ach (%)	Bch (%)	Ach (%)	Bch (%)	Ach (%)	Bch (%)	Ach (%)	Bch (%)
00	100	0	100	0	100	0	100	0	100	0	100	0	100	0		
01	100	1														
02	100	2	100	2												
03	100	4														
04	100	5	100	5	100	5										
05	100	6														
06	100	7	100	7												
07	100	9														
08	100	10	100	10	100	10	100	10								
09	99	11														
010	99	12	99	12												
011	99	13														
012	99	15	99	15	99	15										
013	99	16														
014	99	17	99	17												
015	98	18														
016	98	20	98	20	98	20	98	20	98	20						
017	98	21														
018	98	22	98	22												
019	97	23														
020	97	24	97	24	97	24										
021	97	25														
022	96	27	96	27												
023	96	28														
024	96	29	96	29	96	29	96	29								
025	95	30														
026	95	31	95	31												
027	95	33														
028	94	34	94	34	94	34										
029	94	35														
030	93	36	93	36												
031	93	37														
032	92	38	92	38	92	38	92	38	92	38	92	38				
033	92	39														
034	91	41	91	41												

STEP	1/128		1/64		1/32		1/16		1/8		1/4		1/2		Full	
	Ach (%)	Bch (%)	Ach (%)	Bch (%)	Ach (%)	Bch (%)	Ach (%)	Bch (%)	Ach (%)	Bch (%)	Ach (%)	Bch (%)	Ach (%)	Bch (%)	Ach (%)	Bch (%)
—																
035	91	42														
036	90	43	90	43	90	43										
037	90	44														
038	89	45	89	45												
039	89	46														
040	88	47	88	47	88	47	88	47								
041	88	48														
042	87	49	87	49												
043	86	50														
044	86	51	86	51	86	51										
045	85	52														
046	84	53	84	53												
047	84	55														
048	83	56	83	56	83	56	83	56	83	56						
049	82	57														
050	82	58	82	58												
051	81	59														
052	80	60	80	60	80	60										
053	80	61														
054	79	62	79	62												
055	78	62														
056	77	63	77	63	77	63	77	63								
057	77	64														
058	76	65	76	65												
059	75	66														
060	74	67	74	67	74	67										
061	73	68														
062	72	69	72	69												
063	72	70														
064	71	71	71	71	71	71	71	71	71	71	71	71	71	71	100	100
065	70	72														
066	69	72	69	72												
067	68	73														
068	67	74	67	74	67	74										
069	66	75														
070	65	76	65	76												

STEP	1/128		1/64		1/32		1/16		1/8		1/4		1/2		Full	
	Ach (%)	Bch (%)	Ach (%)	Bch (%)	Ach (%)	Bch (%)	Ach (%)	Bch (%)	Ach (%)	Bch (%)	Ach (%)	Bch (%)	Ach (%)	Bch (%)	Ach (%)	Bch (%)
—																
071	64	77														
072	63	77	63	77	63	77	63	77								
073	62	78														
074	62	79	62	79												
075	61	80														
076	60	80	60	80	60	80										
077	59	81														
078	58	82	58	82												
079	57	82														
080	56	83	56	83	56	83	56	83	56	83						
081	55	84														
082	53	84	53	84												
083	52	85														
084	51	86	51	86	51	86										
085	50	86														
086	49	87	49	87												
087	48	88														
088	47	88	47	88	47	88	47	88								
089	46	89														
090	45	89	45	89												
091	44	90														
092	43	90	43	90	43	90										
093	42	91														
094	41	91	41	91												
095	39	92														
096	38	92	38	92	38	92	38	92	38	92	38	92				
097	37	93														
098	36	93	36	93												
099	35	94														
0100	34	94	34	94	34	94										
0101	33	95														
0102	31	95	31	95												
0103	30	95														
0104	29	96	29	96	29	96	29	96								
0105	28	96														
0106	27	96	27	96												

STEP	1/128		1/64		1/32		1/16		1/8		1/4		1/2		Full	
	Ach (%)	Bch (%)	Ach (%)	Bch (%)	Ach (%)	Bch (%)	Ach (%)	Bch (%)	Ach (%)	Bch (%)	Ach (%)	Bch (%)	Ach (%)	Bch (%)	Ach (%)	Bch (%)
0107	25	97														
0108	24	97	24	97	24	97										
0109	23	97														
0110	22	98	22	98												
0111	21	98														
0112	20	98	20	98	20	98	20	98	20	98						
0113	18	98														
0114	17	99	17	99												
0115	16	99														
0116	15	99	15	99	15	99										
0117	13	99														
0118	12	99	12	99												
0119	11	99														
0120	10	100	10	100	10	100	10	100								
0121	9	100														
0122	7	100	7	100												
0123	6	100														
0124	5	100	5	100	5	100										
0125	4	100														
0126	2	100	2	100												
0127	1	100														
0128	0	100	0	100	0	100	0	100	0	100	0	100	0	100		

8.8. RESET Function

The RESET pin initializes the internal electrical angle.

RESET pin input	Function
L	Normal operation mode
H	Sets the electrical angle to the initial condition.

Note: Digital filter of 0.625 μ s (\pm 20 %) is implemented to the RESET pin.

The current for each channel (while RESET pin is applied) is shown in the table below. MO pin will show L at this time.

Step resolution setting	Ach current setting	Bch current setting	Default electrical angle
Full step	100%	100%	45°
Half step	71%	71%	45°
Quarter step	71%	71%	45°
1/8 step	71%	71%	45°
1/16 step	71%	71%	45°
1/32 step	71%	71%	45°
1/64 step	71%	71%	45°
1/128 step	71%	71%	45°

8.9. Torque Function

By using this pin it is possible to switch the motor torque setting.

TORQE	Function
L	Set torque: 100%
H	Set torque: 50%

8.10. CLK Edge Function

CLK edge function can be selected the CLK signal's rising edge or the CLK edge's dual (up and down).

EDG_SEL pin input	Function
L	Single edge (Only Up Edge of CLK Signal)
H	Dual edge (Up and Down edge)

8.11. RS Function

RS function can be selected either ACDS mode or external sense RS resistor mode.

RS_SEL pin input	Function
L	ACDS (RS resistor less) mode
H	External sense RS resistor mode

Note: PCB board should be designed according to RS Function.

8.12. Gain Function

Gain function can be change $V_{ref}(gain)$. $V_{ref}(gain)$ can be selected either 1/5 or 1/10.

GAIN_SEL pin input	Function
L	Set $V_{ref}(gain)$ to 1/5
H	Set $V_{ref}(gain)$ to 1/10

8.13. Selectable Mixed Decay Function

The Selectable Mixed Decay can adjust the current regeneration amount during the period of current regeneration (Decay) using pins.

Though the Mixed Decay is determined by controlling 2 different types of decay (Fast Decay and Slow Decay), this function enables the user to select the ratio of the Mixed Decay using MDT0 and MDT1 pin. (2bit, 4 function)

MDT1 pin input	MDT0 pin input	Function
L	L	Fast Decay: 37.5% (Fast Decay = OSCM × 6)
L	H	Fast Decay: 50% (Fast Decay = OSCM × 8)
H	L	Fast Decay only
H	H	ADMD

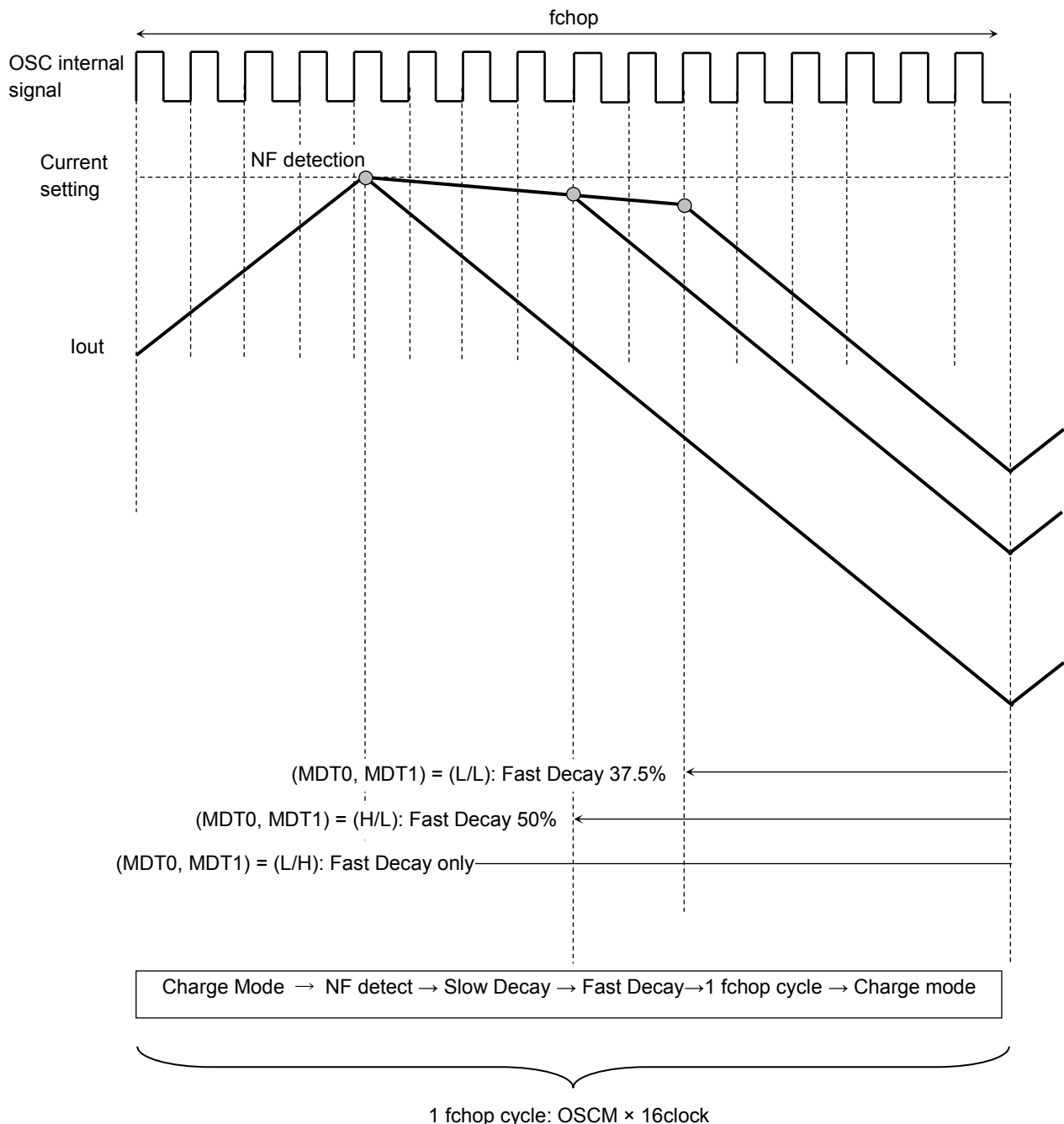

Note: Timing charts may be simplified for explanatory purpose.

8.13.1. Mixed Decay Waveform (Current Waveform)

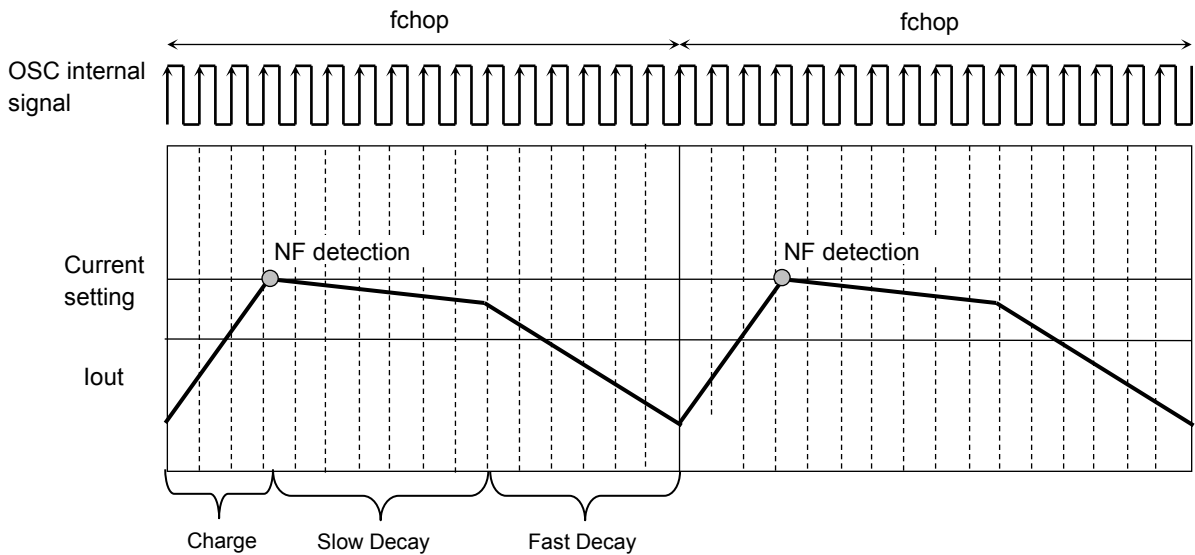

Note: Timing charts may be simplified for explanatory purpose.

8.13.2. Constant Current PWM Function and Timings

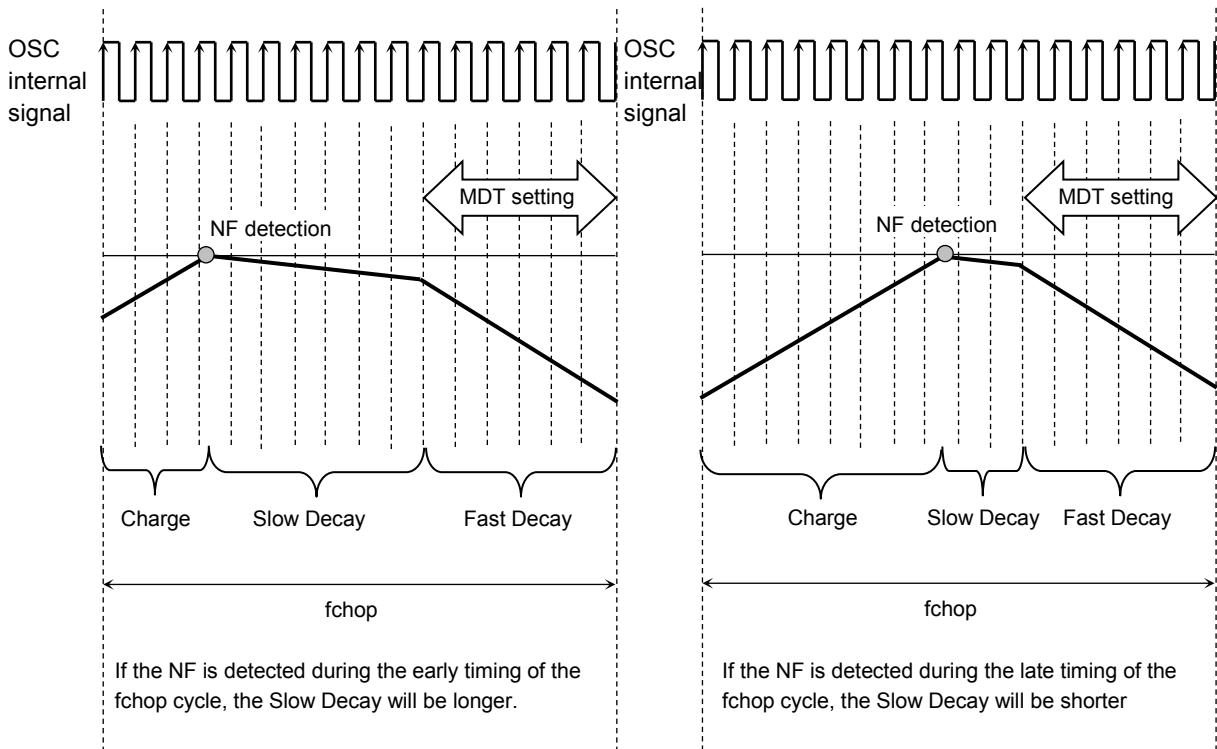

The Charge period is determined by the operating status.

Therefore the NF detect timing within the chopping cycle will change. If NF is detected in the early period of the fchop cycle, the Slow Decay will be longer. If NF is detected in the late period of the fchop cycle, the Slow Decay will be shorter, as shown above.

Note: The chopping cycle is determined as: $f_{chop} - (\text{Charge} + \text{Fast decay}) = \text{Slow Decay}$
(Fast Decay ratio can be changed by MDT0 pin and MDT1 pin setting.)

Note: Timing charts may be simplified for explanatory purpose.

8.13.3. Constant Current PWM Function and Timing

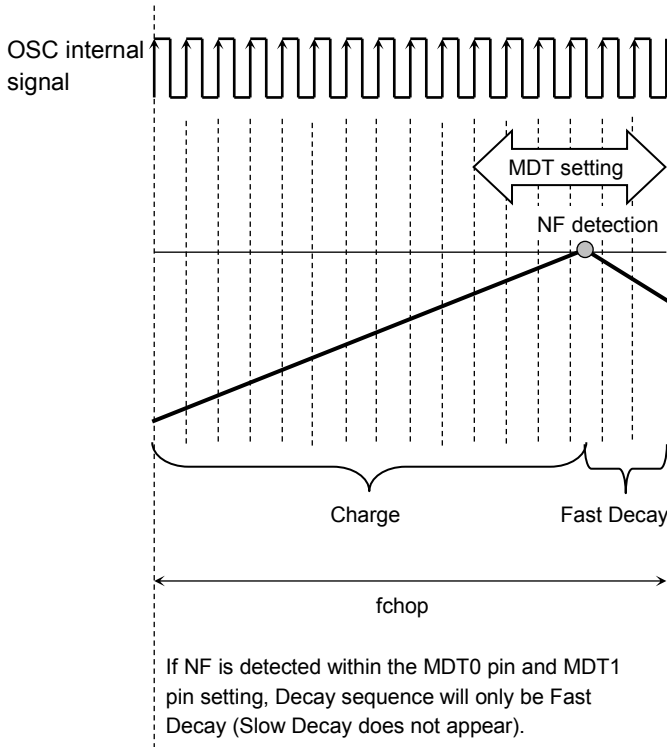

Note: Timing charts may be simplified for explanatory purpose.

8.13.4. Mixed Decay current waveform

- **When the next current step is higher:**

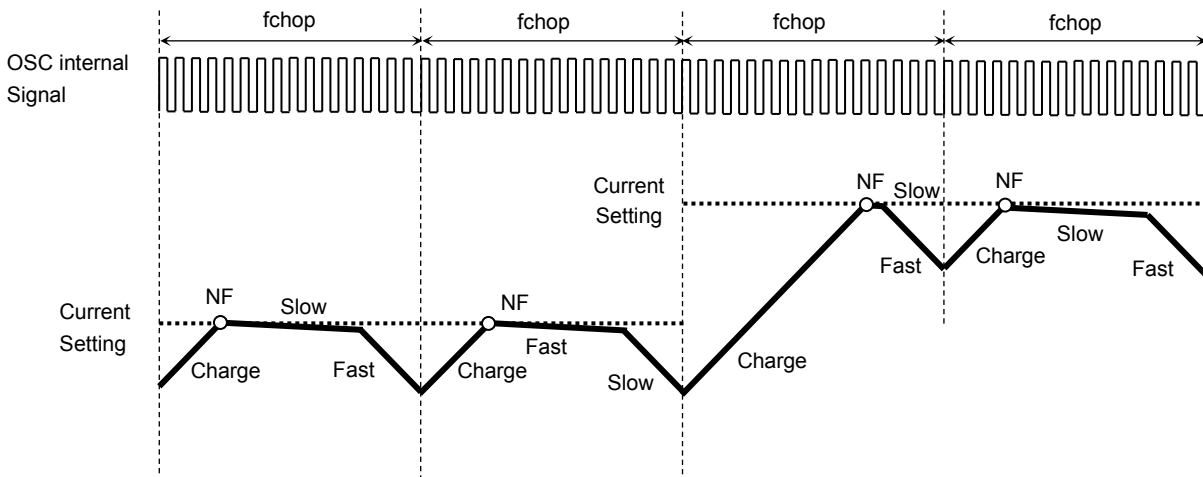

- **When Charge Period is More Than 1 fchop Cycle:**

When the Charge period is longer than fchop cycle, the Charge period extends until the motor current reaches the NF threshold. Once the current reaches the next current step, then the sequence goes on to decay mode.

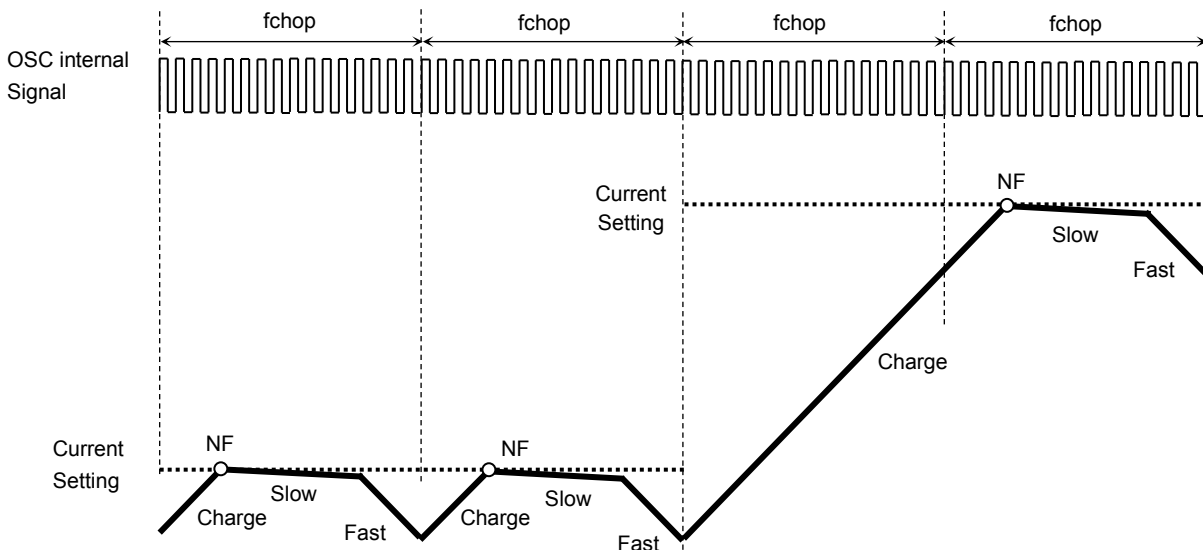

- **When the Next Current Step is Lower:**

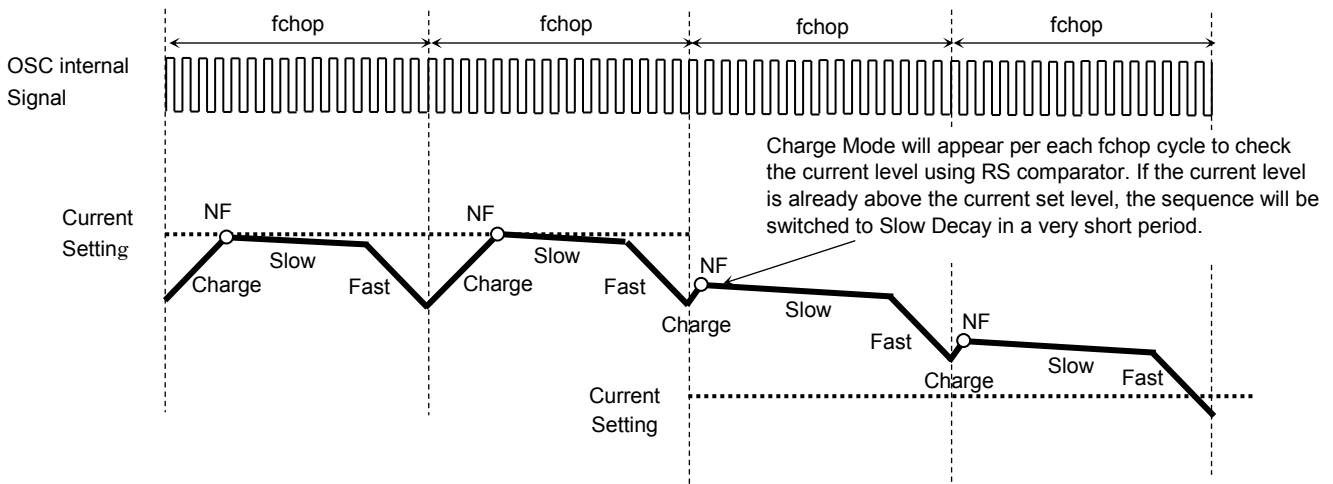

Note: Timing charts may be simplified for explanatory purpose.

8.13.5. ADMD (Advanced Dynamic Mixed Decay) Constant Current Control (MDT0 pin = H, MDT1 pin = H)

The TB5128FTG supports the Advanced Dynamic Mixed Decay (ADMD) which monitors both charge and discharge current during constant current PWM. The basic sequence of the ADMD is as shown below.

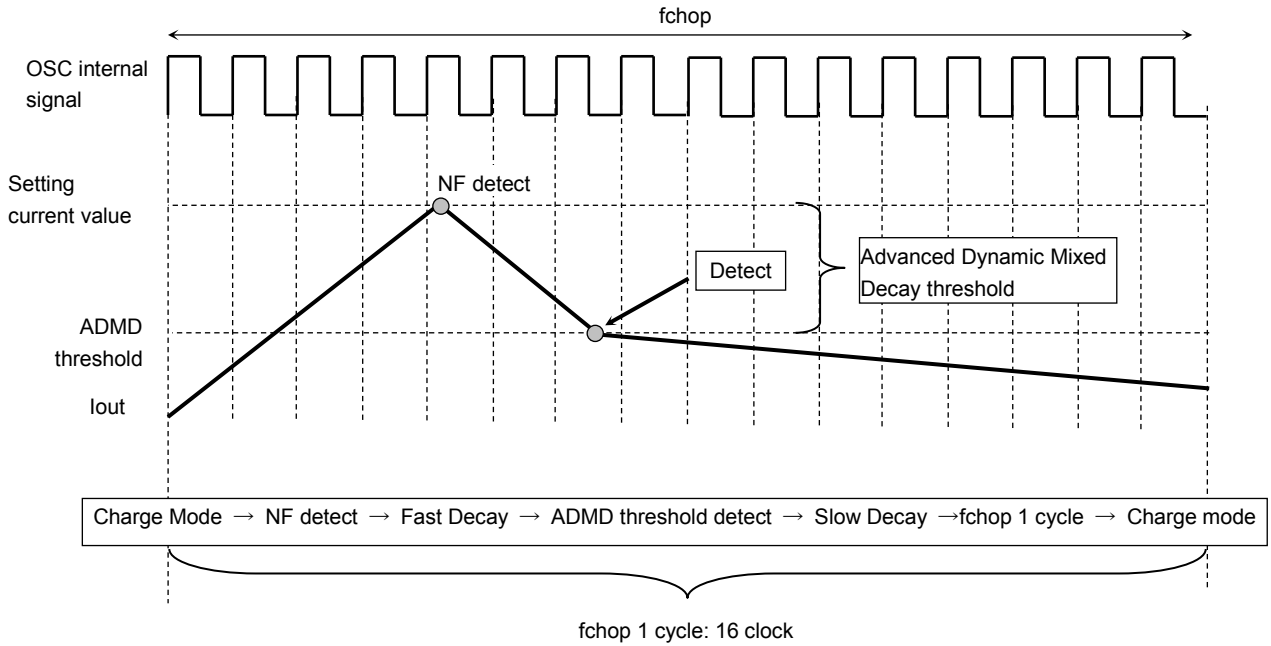

Note: Timing charts may be simplified for explanatory purpose.

8.13.5.1. Auto Decay Mode Current Waveform

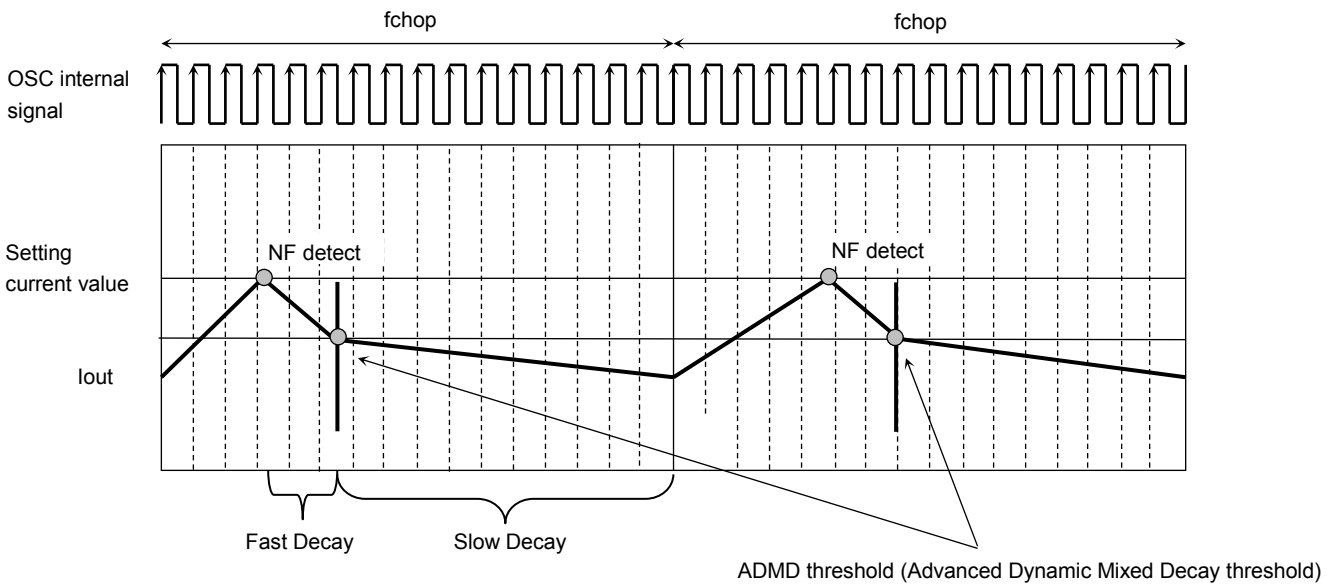

Note: Timing charts may be simplified for explanatory purpose.

8.13.5.2. Auto Decay Mode Current Waveform

- When the Next Current Step is Higher:

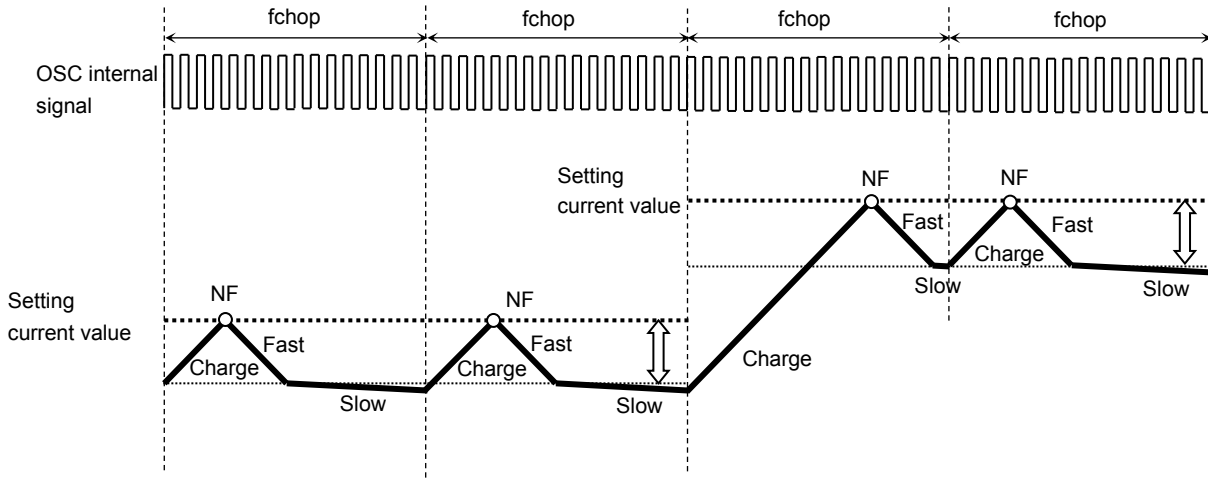

- When Charge Period is More Than 1 fchop Cycle:

When the Charge period is longer than fchop cycle, the Charge period will be extended until the motor current reaches the NF threshold. Once the current reaches the next current step, then the sequence will go on to decay mode.

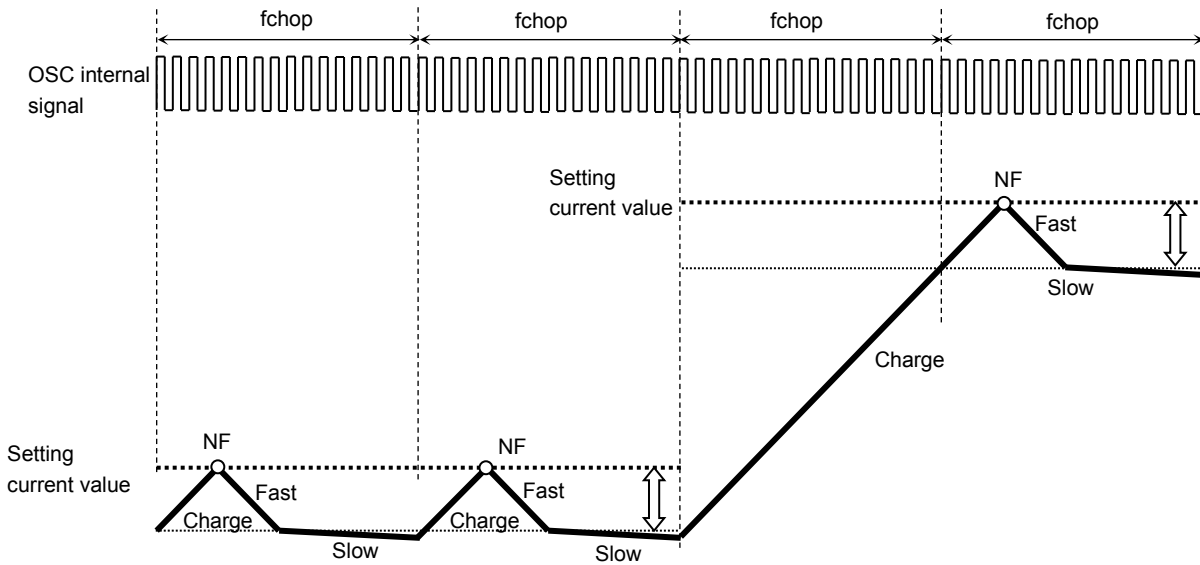

Note: Timing charts may be simplified for explanatory purpose.

● **When the Next Current Step is Lower:**

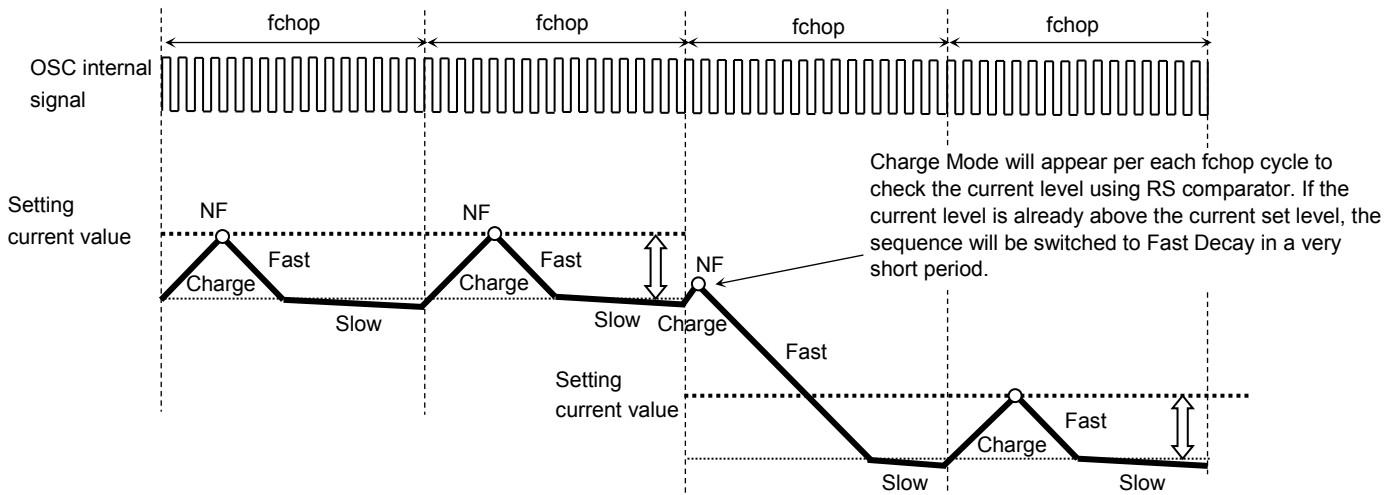

● **When the Fast Continues Past 1 fchop Cycle (the motor current not reaching the ADMD threshold during 1 fchop cycle)**

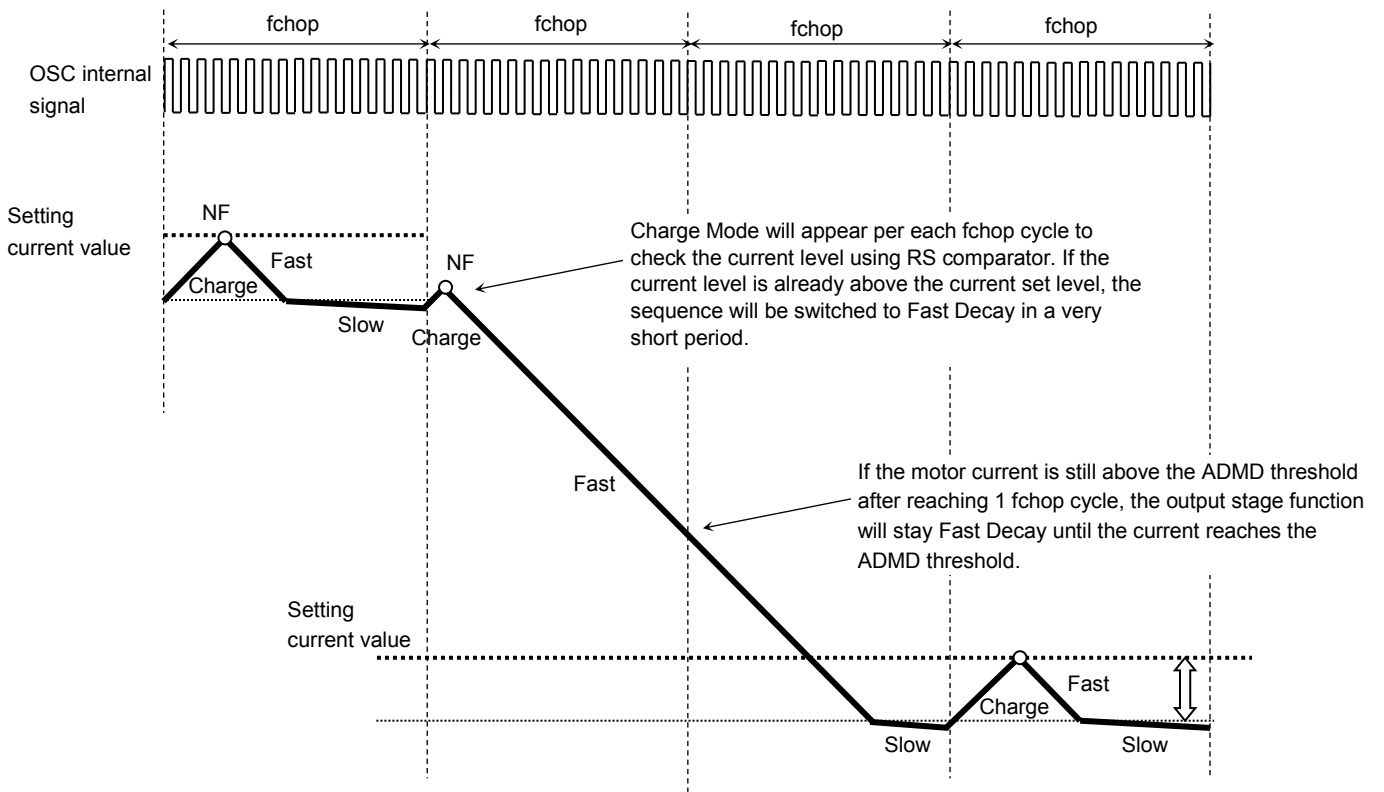

Note: Timing charts may be simplified for explanatory purpose.

9. Functional Description 2 (for Serial mode when IF_SEL pin = H)

When IF_SEL pin = H, the interface is serial input. It performs setting and motor control in the following 32 bit format.

When BANK_EN pin is L, initial setting is performed. When the BANK_EN pin is H, the motor is controlled.

For the motor control, each current value is set in the serial setting, and the output is updated to the set current value at the timing of the LATCH signal.

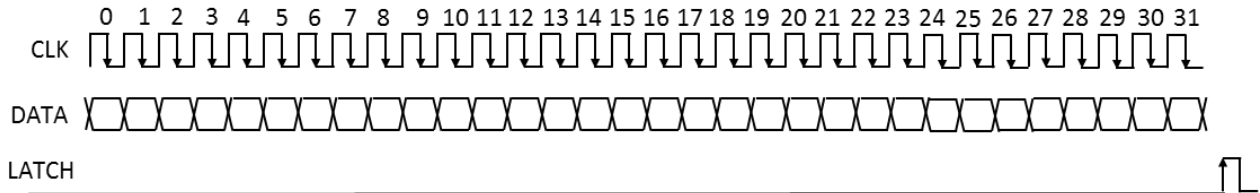

BANK_EN = L: Initial setting

D0	D1	D2	D3	D4	D5	D6	D7	D8	D9	D10	D11	D12	D13	D14	D15
0	0	0	0	0	0	0	0	0	0	0	0	RS_SEL	GAIN_SEL	0	0
D16	D17	D18	D19	D20	D21	D22	D23	D24	D25	D26	D27	D28	D29	D30	D31
0	0	0	0	0	0	0	0	0	0	0	0	0	0	0	0

Note: The data which has a same name as a pin name in CLK mode performs as same as the pin in CLK mode.

BANK_EN = H: Motor controlling

D0	D1	D2	D3	D4	D5	D6	D7	D8	D9	D10	D11	D12	D13	D14	D15
0	0	TOR_QE0	TOR_QE1	TOR_QE2	0	MDT_A0	MDT_A1	PHA	CA0	CA1	CA2	CA3	CA4	CA5	CA6
D16	D17	D18	D19	D20	D21	D22	D23	D24	D25	D26	D27	D28	D29	D30	D31
CA7	CA8	CA9	MDT_B0	MDT_B1	PHB	CB0	CB1	CB2	CB3	CB4	CB5	CB6	CB7	CB8	CB9

Note: Every issuing a command, the current setting transfers by one step.

9.1. Registers When BANK_EN pin = H

The registers when BANK_EN pin = H are shown below.

9.1.1. PHx (x = A and B)

The polality of the output current can be selected by PHx register for each channels.

PHx register setting	Function
L	Setting the direction of the output current to minus
H	Setting the direction of the output current to plus

9.1.2. Cx0 to Cx9 (x = A or B)

The output of each channel's DAC for current limitation can be set by Cx0 to Cx9. The relation between Setting DAC and the output current (Iout) are showw below.

A) External Sense Resistor mode

$$I_{out}(\max) = V_{ref}(\text{gain}) \times \frac{V_{ref}(V)}{RS(\Omega)} \times \frac{Cx[9:0]}{1023} \times \text{Setting torque by the torque function}(\%)$$

(x = A or B)

B) RS Resistor Less Mode (ACDS)

$$V_{ref}(\text{gain}) = \frac{1}{5} \text{ (typ.) (when GAIN_SEL pin = L)}$$

$$I_{out}(\max) = 1.56 \times V_{ref}(V) \times \frac{Cx[9:0]}{1023} \times \text{Setting torque by the torque function}(\%)$$

$$V_{ref}(\text{gain}) = \frac{1}{10} \text{ (typ.) (when GAIN_SEL pin = H)}$$

$$I_{out}(\max) = 0.78 \times V_{ref}(V) \times \frac{Cx[9:0]}{1023} \times \text{Setting torque by the torque function}(\%)$$

(x = A or B)

9.1.3. Torque function(D[2:4])

By using this terminal it is possible to switch the motor torque setting.

TORQE2	TORQE1	TORQE0	Function
0	0	0	Torque:100%
		1	Torque:85%
	1	0	Torque:70%
		1	Toque:60%
1	0	0	Toque:50%
		1	Toque:40%
	1	0	Toque:25%
		1	Toque:10%

9.2. Serial setting example when driving a motor

Serial setting example for motor operation is shown below.

1. Set the BANK_EN pin L. Initial setting is performed under this condition.
2. Then, set the BANK_EN pin H and configure the motor control to turn on the output transistors.
3. Transmit the 1st to 4th commands repeatedly by keeping the BANK_EN pin level H. The motor operates with full step resolution.

1st command

D0	D1	D2	D3	D4	D5	D6	D7	D8	D9	D10	D11	D12	D13	D14	D15
0	0	0	0	0	0	0	0	1	1	1	1	1	1	1	1

D16	D17	D18	D19	D20	D21	D22	D23	D24	D25	D26	D27	D28	D29	D30	D31
1	1	1	0	0	1	1	1	1	1	1	1	1	1	1	1

2nd command

D0	D1	D2	D3	D4	D5	D6	D7	D8	D9	D10	D11	D12	D13	D14	D15
0	0	0	0	0	0	0	0	0	1	1	1	1	1	1	1

D16	D17	D18	D19	D20	D21	D22	D23	D24	D25	D26	D27	D28	D29	D30	D31
1	1	1	0	0	1	1	1	1	1	1	1	1	1	1	1

3rd command

D0	D1	D2	D3	D4	D5	D6	D7	D8	D9	D10	D11	D12	D13	D14	D15
0	0	0	0	0	0	0	0	0	1	1	1	1	1	1	1

D16	D17	D18	D19	D20	D21	D22	D23	D24	D25	D26	D27	D28	D29	D30	D31
1	1	1	0	0	0	1	1	1	1	1	1	1	1	1	1

4th command

D0	D1	D2	D3	D4	D5	D6	D7	D8	D9	D10	D11	D12	D13	D14	D15
0	0	0	0	0	0	0	0	1	1	1	1	1	1	1	1

D16	D17	D18	D19	D20	D21	D22	D23	D24	D25	D26	D27	D28	D29	D30	D31
1	1	1	0	0	0	1	1	1	1	1	1	1	1	1	1

10. Common Function (When CLK Mode and Serial Mode)

10.1. LO (Error detect flag output) Function

When an error detection function performs, the LO function outputs an error detection as a signal from LO0 and LO1 pins to the outside of TB5128FTG.

The LO0 and LO1 pins are open-drain output pins. The LO0 and LO1 pins need to be pulled up to VCC level via 10 k to 100 kΩ resistor.

During regular operation, the level of LO0 and LO1 pins will stay Hi-Z (the internal MOSFET is OFF, the level of these pins are VCC level).

When the thermal shutdown (TSD), Over current (ISD), or motor load open (OPD) occurs, the LO0 and/or LO1 pins will become L (the internal MOSFET is ON).

When the error detection is released by reasserting the VM power supply or setting the device to STANDBY mode, the LO0 and LO1 pins show “normal status”.

Leave the LO0 and LO1 pins open when not using these functions.

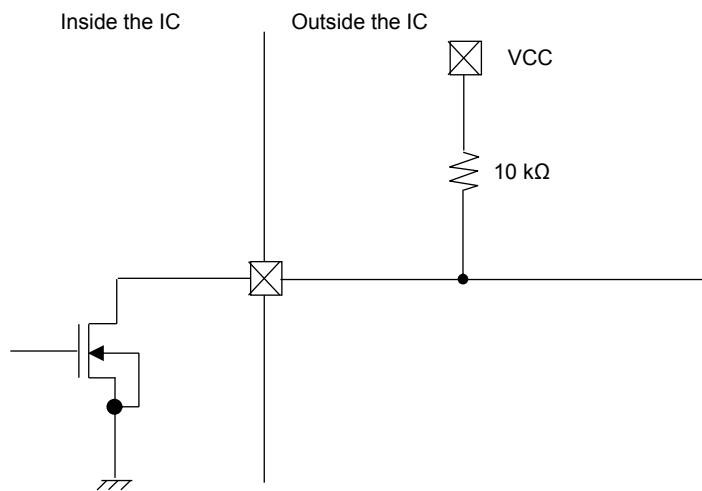

Note: This figure may be simplified for explanatory purpose.

LO0 pin output	LO1 pin output	Function
Hi-Z	Hi-Z	Normal status (Normal operation)
Hi-Z	L	Detected motor load open (OPD)
L	Hi-Z	Detected over current (ISD)
L	L	Detected thermal shutdown (TSD)

TSD and ISD are latch type. OPD will be of automatic return type.

10.1.1 OPD Function

For the system, when the output current does not reach the zero current threshold (25mA) in the period of 200 μ s after Charge starts, OPD is output.

Even when OPD works, Motor output does not stop and operation continues. Not standby mode.

The output is monitoring both Ach and Bch.

When using OPD, please judge it is open when LO1 is Low level for a certain period.

•When Motor's connector is open

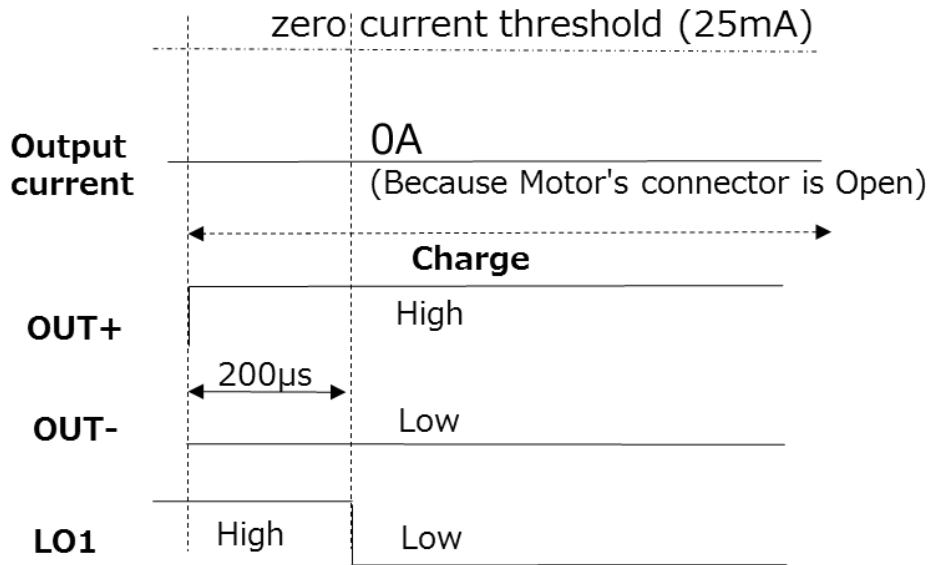

•When the L value of Motor is large

Since the slope of the current is loose, it is detected as OPD.

※The timing to release OPD detection is Charge end after NF detection.

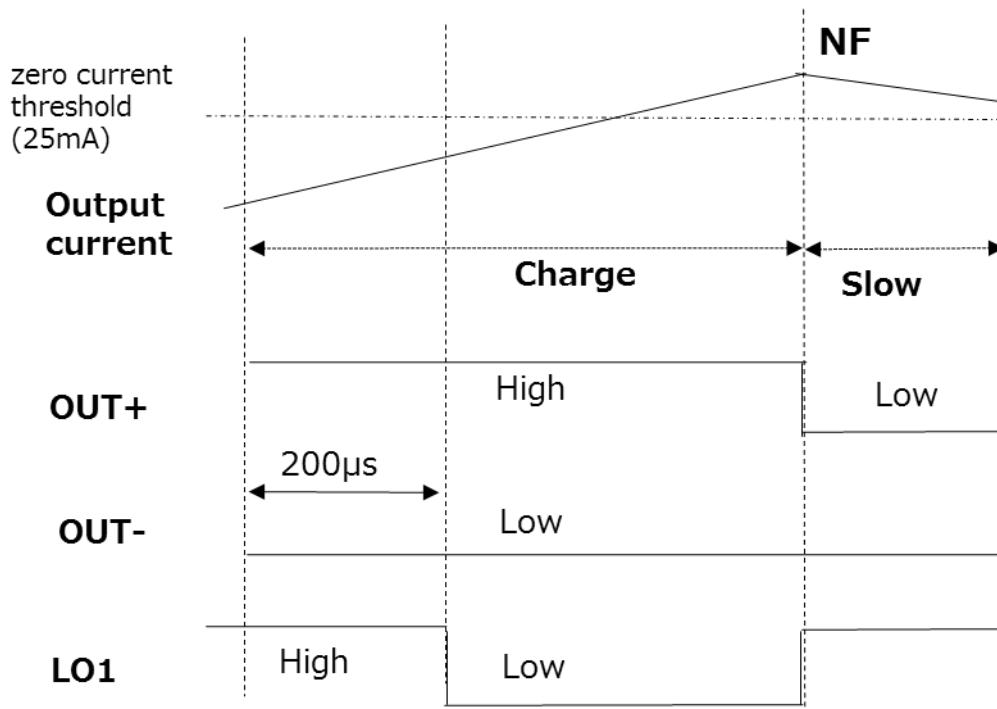

•When the set current is small

Because the current setting is low, OPD detection works momentarily.

※The timing to release OPD detection is Charge end after NF detection.

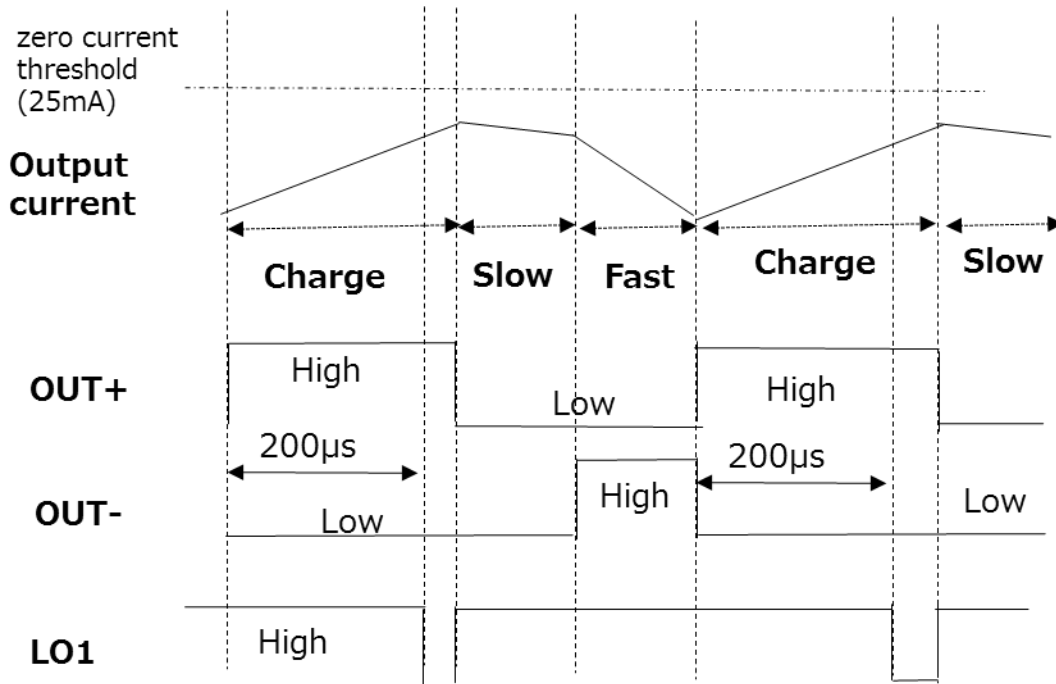

10.2. STANDBY Function

It is possible to switch to Standby mode by switching this pin.

STANDBY pin input	Function
L	Standby mode
H	Normal operation

Note: In STANDBY pin = L, an internal oscillating circuit and a motor output part are stopped. At this time, the motor cannot be driven.

11. Output Transistor Function Mode

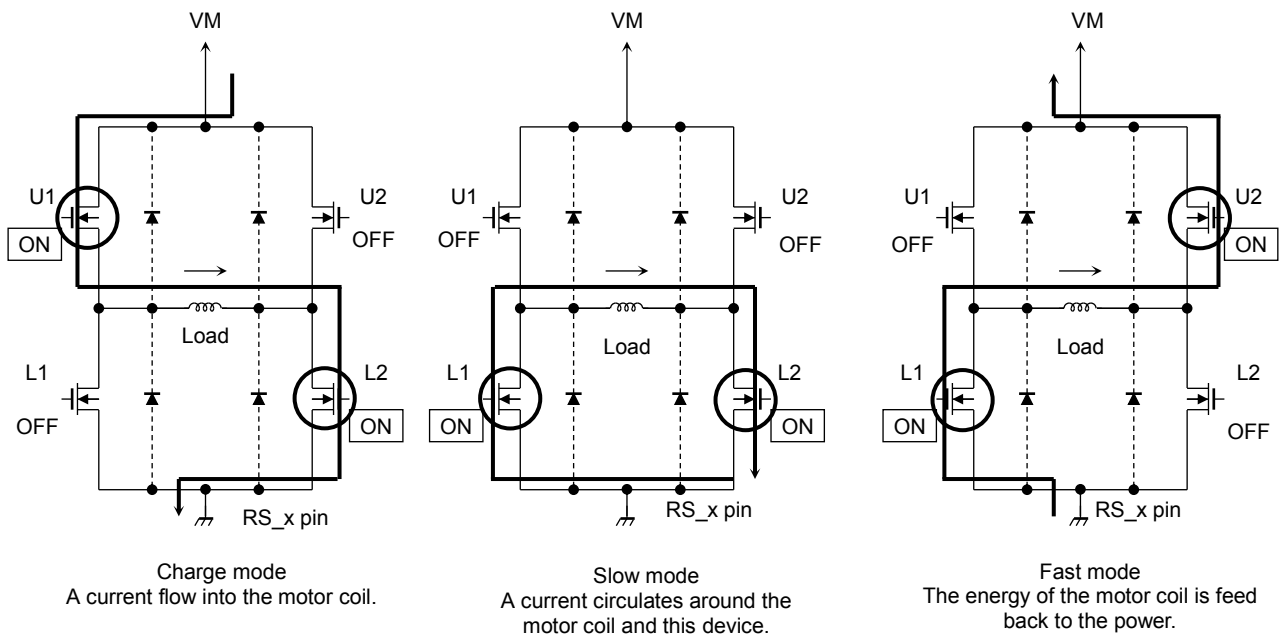

Note: x = A or B

Note: The equivalent circuit diagrams may be simplified or some parts of them may be omitted for explanatory purposes.

Output transistor function

MODE	U1	U2	L1	L2
CHARGE	ON	OFF	OFF	ON
SLOW	OFF	OFF	ON	ON
FAST	OFF	ON	ON	OFF

Note: This table shows an example of when the current flows as indicated by the arrows in the figures shown above. If the current flows in the opposite direction, refer to the following table.

MODE	U1	U2	L1	L2
CHARGE	OFF	ON	ON	OFF
SLOW	OFF	OFF	ON	ON
FAST	ON	OFF	OFF	ON

This IC controls the motor current to be constant by changing 3 modes listed above automatically.

12. Calculation of the Predefined Output Current

12.1. External Sense Resistor mode

For PWM constant-current control, this IC uses a clock generated by the OSCM oscillator.

The peak output current (Setting current value) can be set via the current-sensing resistor (RS) and the reference voltage (Vref), as follows:

$$I_{out}(\max) = V_{ref}(\text{gain}) \times \frac{V_{ref}(\text{V})}{R_S(\Omega)}$$

Note: When GAIN_SEL pin = L, $V_{ref}(\text{gain}) = \frac{1}{5}$ (typ.). And When GAIN_SEL pin = H, $V_{ref}(\text{gain}) = \frac{1}{10}$ (typ.).

For example:

When $V_{ref} = 3.0$ (V), $R_S = 0.22 \Omega$, Torque = 100% and $V_{ref}(\text{gain}) = \frac{1}{5}$ (typ.) (When GAIN_SEL pin = L), motor constant current (Setting current value) will be calculated by the following expressions.

$$I_{out}(\max) = \frac{1}{5} \times \frac{3(\text{V})}{0.22(\Omega)} = 2.73 \text{ A}$$

12.2. RS Resistor Less Mode (ACDS)

The $I_{out}(\max)$ will be calculated by the following expressions.

When $V_{ref}(\text{gain}) = \frac{1}{5}$ (typ.) (GAIN_SEL = L)

$$I_{out}(\max) = 1.56 \times V_{ref}(\text{V})$$

When $V_{ref}(\text{gain}) = \frac{1}{10}$ (typ.) (GAIN_SEL = H)

$$I_{out}(\max) = 0.78 \times V_{ref}(\text{V})$$

13. Calculation of the OSCM Oscillation Frequency (chopper reference frequency)

An approximation of the OSCM oscillation frequency (f_{OSCM}) and chopper frequency (f_{chop}) can be calculated by the following expressions.

$$f_{OSCM} = \frac{1}{0.56 \times \{\text{COSC} \times (\text{ROSC} + 500)\}}$$

$$f_{chop} = \frac{f_{OSCM}}{16}$$

Note: COSC: Capacitor connected to OSCM pin, ROSC: Resistor connected to OSCM pin

For example:

When $\text{COSC} = 270$ pF and $\text{ROSC} = 5.1$ k Ω , f_{OSCM} frequency will be calculated by following expressions.

$$f_{OSCM} = \frac{1}{0.56 \times \{270 \text{ pF} \times (5.1 \text{ k}\Omega + 500)\}} \approx 1.2 \text{ (MHz)}(\text{typ.})$$

$$f_{chop} = \frac{f_{OSCM}}{16} = \frac{1.2 \text{ (MHz)}}{16} \approx 75 \text{ (kHz)}$$

If chopping frequency is raised, Rippl of current will become small and wave-like reproducibility will improve. However, the gate loss inside IC goes up and generation of heat becomes large.

By lowering chopping frequency, reduction in generation of heat is expectable. However, Rippl of current may become large.

It is a standard about 70 kHz. A setup in the range of 50k to 100 kHz is recommended.

14. Absolute Maximum Ratings (Ta = 25°C)

Characteristics	Symbol	Rating	Unit	Remarks
Motor output voltage	Vout	50	V	—
Motor power supply (non active)	VM	50	V	STANDBY pin = L
Motor power supply (active)		-0.4 to 44	V	STANDBY pin = H
Motor output current	Iout	5.0	A	(Note1)
Charge pump voltage	VCPP	VM ± 6 V	V	—
	VCPM	VM ± 6 V	V	—
	VCPO	50	V	—
Internal Logic power supply	VCC	6.0	V	When externally applied.
Logic input voltage	VIN(H)	6.0	V	—
	VIN(L)	-0.4	V	—
MO output voltage	VMO	6.0	V	—
LO0, LO1 output voltage	VLO	6.0	V	—
MO Inflow current	IMO	6.0	mA	—
LO0, LO1 Inflow current	ILO	6.0	mA	—
Power dissipation	PD	1.2	W	(Note2)
Operating temperature	Topr	-40 to 85	°C	—
Storage temperature	Tstg	-55 to 150	°C	—
Junction temperature	Tj(max)	150	°C	—

Note1: Usually, the maximum current value at the time should use 70% or less of the absolute maximum ratings for a standard on thermal rating. The maximum output current may be further limited in view of thermal considerations, depending on ambient temperature and board conditions.

Note2: Device alone (Ta =25°C)

When Ta exceeds 25°C, it is necessary to do the derating with 9.6 mW/°C.

Ta: Ambient temperature

Topr: Ambient temperature while the IC is active

Tj: Junction temperature while the IC is active. The maximum junction temperature is limited by the thermal shutdown (TSD) circuitry. It is advisable to keep the maximum current below a certain level so that the maximum junction temperature, Tj (MAX), will not exceed 120°C.

Caution) Absolute maximum ratings

The absolute maximum ratings of a semiconductor device are a set of ratings that must not be exceeded, even for a moment. Do not exceed any of these ratings.

Exceeding the rating (s) may cause device breakdown, damage or deterioration, and may result in injury by explosion or combustion.

The value of even one parameter of the absolute maximum ratings should not be exceeded under any circumstances. The TB5128FTG does not have overvoltage detection circuit. Therefore, the device is damaged if a voltage exceeding its rated maximum is applied.

All voltage ratings, including supply voltages, must always be followed. The other notes and considerations described later should also be referred to.

15. Operation Ranges (Ta=-40 to 85°C)

Characteristics	Symbol	Min	Typ.	Max	Unit	Remarks
Motor power supply	VM	6.5	24	44	V	—
Motor output current	Iout	—	3.0	5.0	A	(Note1)
Logic input voltage	VIN(H)	2.0	—	5.5	V	Logic input H Level
	VIN(L)	0	—	0.8	V	Logic input L Level
MO output pin voltage	VMO	—	3.3	5.0	V	—
LO0, LO1 output pin voltage	VLO	—	3.3	5.0	V	—
Clock input frequency	fCLK	—	—	200	kHz	—
Chopper frequency	fchop (range)	40	70	150	kHz	—
Vref input voltage	Vref	GND	2.0	3.6	V	—

Note1: Maximum current for actual usage may be limited by the operating circumstances such as operating conditions (exciting mode, operating time, and so on), ambient temperature, and heat conditions (board condition and so on).

16. Electrical Specifications 1 (Ta = 25°C, VM = 24 V, unless specified otherwise)

Characteristics	Symbol	Test condition	Min	Typ.	Max	Unit	
Logic input voltage	HIGH	VIN(H)	Logic input (Note1)	2.0	—	5.5	V
	LOW	VIN(L)	Logic input (Note1)	0	—	0.8	V
Logic input hysteresis voltage	VIN(HYS)	Logic input (Note1)	100	—	300	mV	
Logic input current	HIGH	IIN(H)	VIN(H) = 3.3 V	—	33	—	μA
	LOW	IIN(L)	VIN(L) = 0 V	—	—	1	μA
MO output pin voltage	LOW	VOL(MO)	IOL = 5 mA, output = L	—	0.2	0.5	V
LO0, LO1 output pin voltage	LOW	VOL(LO)	IOL = 5 mA, output = L	—	0.2	0.5	V
Current consumption	IM1	Output pins = open Standby mode	—	1.8	3.2	mA	
	IM2	Output pins = open ENABLE pin = L in releasing Standby mode	—	5.5	8.6	mA	
	IM3	Output pins = open Full step resolution	—	8.2	10.4	mA	
Output leakage current	High side	IOH	VM = 44 V, Vout = 0 V	—	—	1	μA
	Low side	IOL	VM = Vout = 44 V	1	—	—	μA
Motor current channel differential	ΔIout1	Current differential between Ch	-5	0	5	%	
Motor current setting accuracy	ΔIout2	Iout = 3.0 A	-5	0	5	%	
RS pin current	IRS	VRS = 0 V	0	—	10	μA	
Motor output ON resistance (High side+Low side)	Ron(H+L)	Tj = 25°C, High side+Low side	—	0.25	0.35	Ω	

Note: When the logic signal is applied to the device whilst the VM power supply is not asserted; the device is designed not to function, but for safe usage, please apply the logic signal after the VM power supply is asserted and the VM voltage reaches the proper operating range.

Note1: VIN(H) is defined as the VIN voltage that causes the outputs (OUT_A+ pin, OUT_A- pin, OUT_B+ pin, OUT_B- pin) to change when a pin under test is gradually raised from 0 V. VIN(L) is defined as the VIN voltage that causes the outputs (OUT_A+ pin, OUT_A- pin, OUT_B+ pin, OUT_B- pin) to change when the pin is then gradually lowered. The difference between VIN(H) and VIN(L) is defined as the VIN(HYS).

17. Electrical Specifications 2

(Ta =25°C, VM = 24 V, unless specified otherwise)

Characteristics	Symbol	Test condition	Min	Typ.	Max	Unit
Vref input current	Iref	Vref = 2.0 V	—	0	1	μA
VCC voltage	VCC	ICC = 5.0 mA	4.75	5	5.25	V
VCC current	ICC	VCC = 5.0 V	—	2.5	5	mA
Vref gain rate	Vref(gain)	Vref = 2.0 V GAIN_SEL pin = L	1/5.2	1/5	1/4.8	—
Thermal shutdown (TSD) threshold (Note1)	TJTSD	—	145	160	175	°C
VM recovery voltage	VMR	—	5.7	6	6.3	V
Over current detection (ISD) threshold (Note2)	ISD	—	5.7	7.2	10	A

Note1: About TSD

When the junction temperature of the device reached the TSD threshold, the TSD circuit is triggered; the internal reset circuit then turns off the output transistors. Noise rejection blanking time is built-in to avoid misdetection. Once the TSD circuit is triggered, the device will be set to standby mode, and can be cleared by reasserting the VM power source, or setting the MODE pins to standby mode. The TSD circuit is a backup function to detect a thermal error, therefore is not recommended to be used aggressively.

Note2: About ISD

When the output current reaches the threshold, the ISD circuit is triggered; the internal reset circuit then turns off the output transistors. Once the ISD circuit is triggered, the device keeps the output off until power-on reset (POR), is reasserted or the device is set to standby mode by MODE pins. For fail-safe, please insert a fuse to avoid secondary trouble.

Back-EMF

While a motor is rotating, there is a timing at which power is fed back to the power supply. At that timing, the motor current recirculates back to the power supply due to the effect of the motor back-EMF.

If the power supply does not have enough sink capability, the power supply and output pins of the device might rise above the rated voltages. The magnitude of the motor back-EMF varies with usage conditions and motor characteristics. It must be fully verified that there is no risk that the TB5128FTG or other components will be damaged or fail due to the motor back-EMF.

Cautions on Overcurrent Shutdown (ISD) and Thermal Shutdown (TSD)

The ISD and TSD circuits are only intended to provide temporary protection against irregular conditions such as an output short-circuit; they do not necessarily guarantee the complete IC safety.

If the device is used beyond the specified operating ranges, these circuits may not operate properly: then the device may be damaged due to an output short-circuit.

The ISD circuit is only intended to provide a temporary protection against an output short-circuit. If such a condition persists for a long time, the device may be damaged due to overstress. Overcurrent conditions must be removed immediately by external hardware.

IC Mounting

Do not insert devices incorrectly or in the wrong orientation. Otherwise, it may cause breakdown, damage and/or deterioration of the device.

18. AC Electrical Specification (Ta = 25°C, VM = 24 V, 6.8 mH/5.7 Ω)

Characteristics	Symbol	Test condition	Min	Typ.	Max	Unit
Inside filter of CLK input minimum High width	tCLK(H)	The CLK(H) minimum pulse width	300	—	—	ns
Inside filter of CLK input minimum Low width	tCLK(L)	The CLK(L) minimum pulse width	250	—	—	ns
Output transistor switching specific	tr	—	30	80	130	ns
	tf	—	40	90	140	ns
	tpLH(CLK)	CLK output	—	1000	—	ns
	tpHL(CLK)	CLK output	—	1500	—	ns
Analog noise blanking time	AtBLK	VM = 24 V, Iout = 3.0 A Analog tblank	250	400	550	ns
Oscillator frequency accuracy	ΔfOSCM	COSC = 270 pF, ROSC = 5.1 kΩ	-15	—	+15	%
Oscillator reference frequency	fOSCM	COSC= 270 pF, ROSC =5.1 kΩ	1020	1200	1380	kHz
Chopping frequency	fchop	Output: Active (Iout = 1.5 A), fOSC = 1200 kHz	—	75	—	kHz

AC Electrical Specification Timing chart

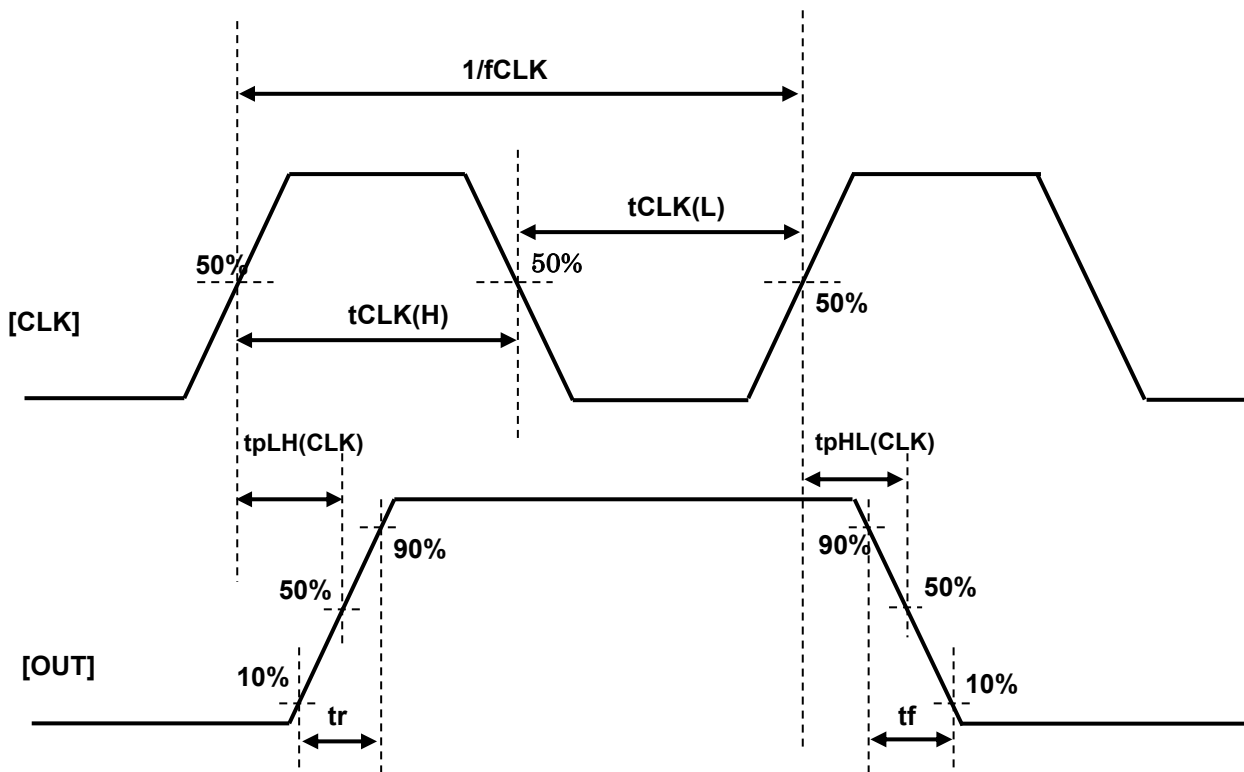

Note: Timing charts may be simplified for explanatory purpose.

19. Other AC Electrical Specification (Ta = 25°C, VM = 24 V, unless specified otherwise)

Characteristics	Symbol	Test condition	Min	Typ.	Max	Unit	No. in Timing Chart
Serial CLK frequency	fSCLK	VIN = 3.3 V	1.0	—	25	MHz	—
CLK Cycle	tsCKW	VIH = 3.3 V, VIL = 0 V, tr = tf = 23 ns	46	—	—	ns	—
Minimum CLK pulse width	tw(CLK)	VIN = 3.3 V	40	—	—	ns	1
	twp(CLK)		20	—	—	ns	2
	twn(CLK)		20	—	—	ns	3
Minimum STROBE pulse width	tSTROBE	VIN = 3.3 V	40	—	—	ns	4
	tSTROBE(H)		20	—	—	ns	5
	tSTROBE(L)		20	—	—	ns	6
Data setup time	tsuSIN - CLK	VIN = 3.3 V	10	—	—	ns	7
	tsuST - CLK		10	—	—	ns	8
Data hold time	thSIN - CLK	VIN = 3.3 V	10	—	—	ns	9
	thST - CLK		10	—	—	ns	10

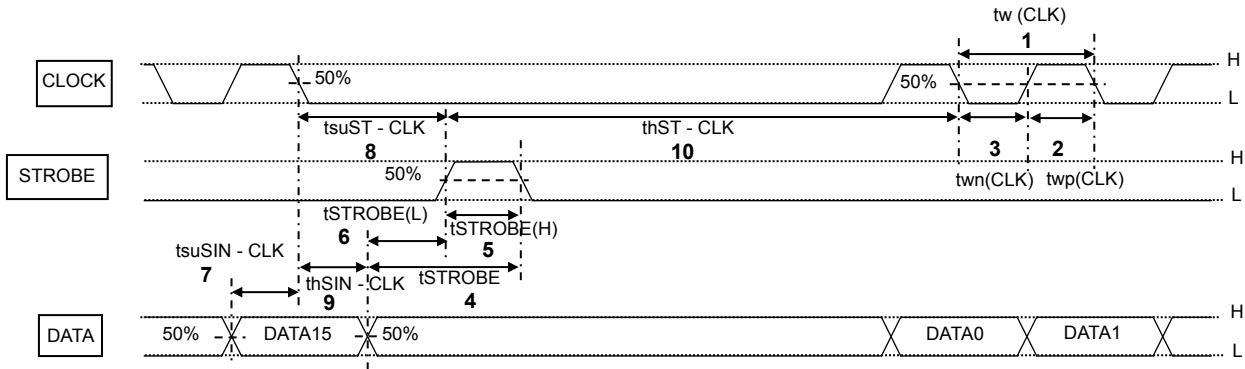

Note: The CLK whose frequency is 1MHz or less may be used if the falling time and the rising time of CLK satisfy above condition.

20. Application Circuit Example (RS_SEL pin = H, IF_SEL pin = L)

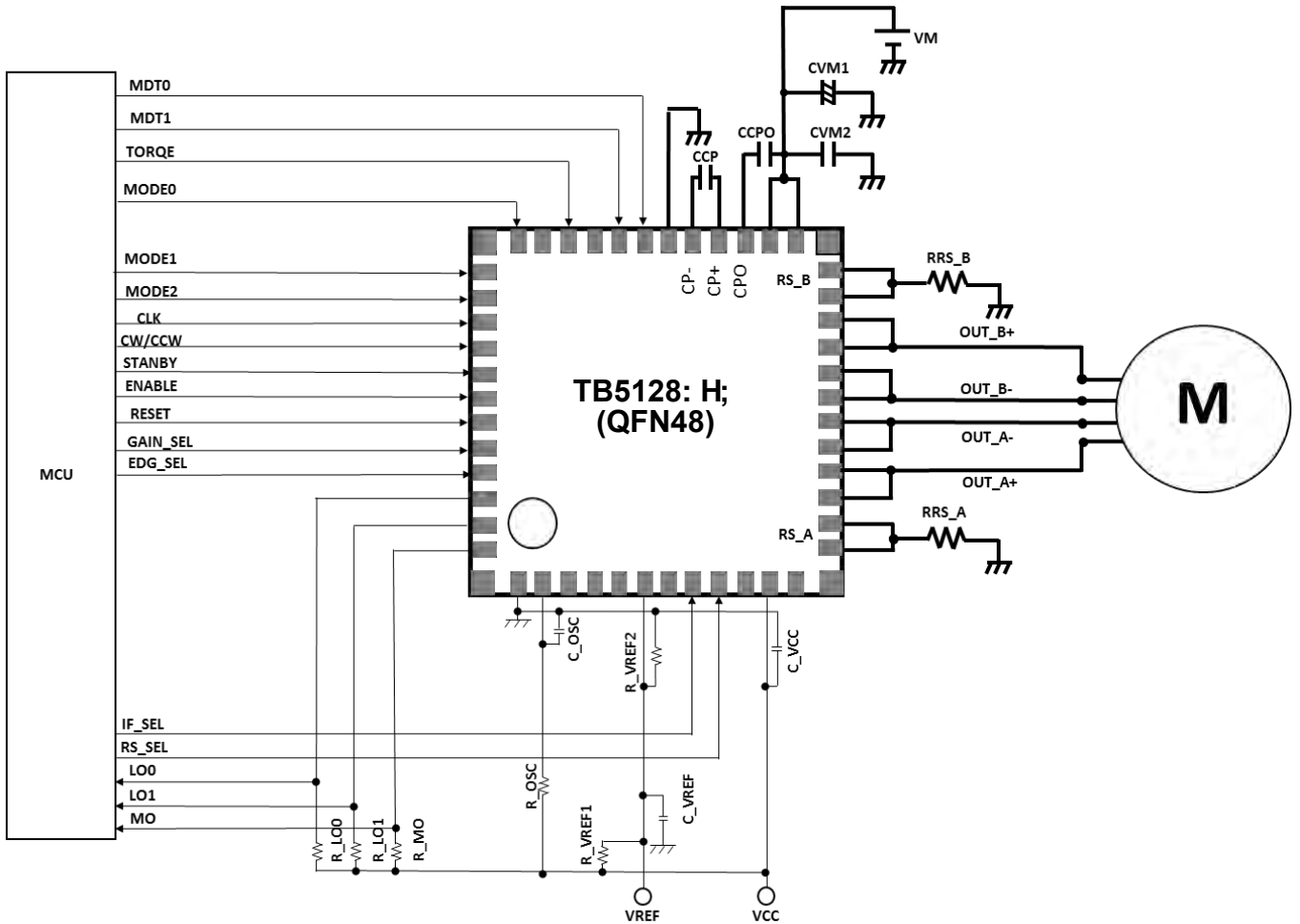

The application circuit shown in this document is provided for reference purposes only. The data for mass production are not guaranteed.

Constant numbers of components (for reference only)

Part's symbol	Component	Reference constant number
CVM1	Electrolytic capacitor	100 μ F (CVM1 \geq 10 μ F)
CVM2	Ceramic capacitor	(0.1 μ F)
CCP	Ceramic capacitor	0.022 μ F
CCPO	Ceramic capacitor	0.22 μ F
C_VCC	Ceramic capacitor	0.1 μ F
R_OSC	Resistor	5.1 k Ω (1.8 k Ω to 8.2 k Ω)
C_OSC	Ceramic capacitor	270 pF
R_VREF1, R_VREF2	Resistor	Arbitrary (10 k Ω \leq R_VREF1 + R_VREF2 \leq 50 k Ω)
C_VREF	Ceramic capacitor	(0.1 μ F)
R_MO	Resistor	10 k Ω (10 k Ω to 100 k Ω)
R_LO0, R_LO1	Resistor	10 k Ω (10 k Ω to 100 k Ω)

Note: Constant numbers in above table are for reference only. Some components outside of the recommendation range can be adopted depending on the usage conditions.

21. Package Dimensions

P-VQFN48-0707-0.50-004

Unit: mm

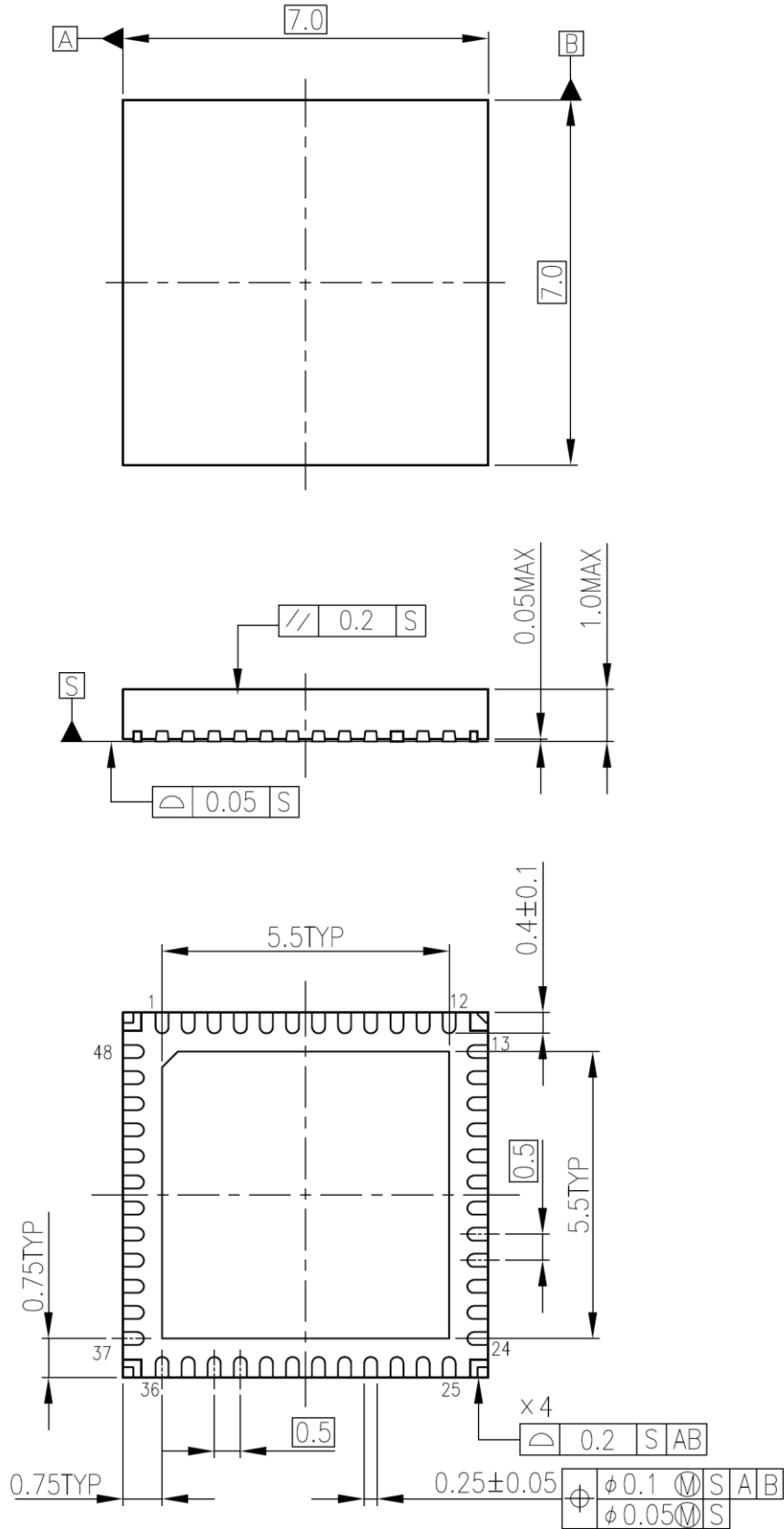

Weight: 0.14 g (typ.)

Notes on Contents

1. Block Diagrams

Some of the functional blocks, circuits, or constants in the block diagram may be omitted or simplified for explanatory purposes.

2. Equivalent Circuits

The equivalent circuit diagrams may be simplified or some parts of them may be omitted for explanatory purposes.

3. Timing Charts

Timing charts may be simplified for explanatory purposes.

4. Application Circuits

The application circuits shown in this document are provided for reference purposes only. Thorough evaluation is required, especially at the mass production design stage.

Providing these application circuit examples does not grant a license for industrial property rights.

5. Test Circuits

Components in the test circuits are used only to obtain and confirm the device characteristics. These components and circuits are not guaranteed to prevent malfunction or failure from occurring in the application equipment.

IC Usage Considerations

Notes on handling of ICs

- (1) The absolute maximum ratings of a semiconductor device are a set of ratings that must not be exceeded, even for a moment. Do not exceed any of these ratings.
Exceeding the rating(s) may cause the device breakdown, damage or deterioration, and may result injury by explosion or combustion.
- (2) Use an appropriate power supply fuse to ensure that a large current does not continuously flow in case of over current and/or IC failure. The IC will fully break down when used under conditions that exceed its absolute maximum ratings, when the wiring is routed improperly or when an abnormal pulse noise occurs from the wiring or load, causing a large current to continuously flow and the breakdown can lead smoke or ignition. To minimize the effects of the flow of a large current in case of breakdown, appropriate settings, such as fuse capacity, fusing time and insertion circuit location, are required.
- (3) If your design includes an inductive load such as a motor coil, incorporate a protection circuit into the design to prevent device malfunction or breakdown caused by the current resulting from the inrush current at power ON or the negative current resulting from the back electromotive force at power OFF. IC breakdown may cause injury, smoke or ignition.
Use a stable power supply with ICs with built-in protection functions. If the power supply is unstable, the protection function may not operate, causing IC breakdown. IC breakdown may cause injury, smoke or ignition.
- (4) Do not insert devices in the wrong orientation or incorrectly.
Make sure that the positive and negative terminals of power supplies are connected properly. Otherwise, the current or power consumption may exceed the absolute maximum rating, and exceeding the rating(s) may cause the device breakdown, damage or deterioration, and may result injury by explosion or combustion.
In addition, do not use any device that is applied the current with inserting in the wrong orientation or incorrectly even just one time.
- (5) Carefully select external components (such as inputs and negative feedback capacitors) and load components (such as speakers), for example, power amp and regulator.
If there is a large amount of leakage current such as from input or negative feedback condenser, the IC output DC voltage will increase. If this output voltage is connected to a speaker with low input withstand voltage, overcurrent or IC failure may cause smoke or ignition. (The overcurrent may cause smoke or ignition from the IC itself.) In particular, please pay attention when using a Bridge Tied Load (BTL) connection-type IC that inputs output DC voltage to a speaker directly.

Points to remember on handling of ICs

(1) Over current Protection Circuit

Over current protection circuits (referred to as current limiter circuits) do not necessarily protect ICs under all circumstances. If the Over current protection circuits operate against the over current, clear the over current status immediately.

Depending on the method of use and usage conditions, such as exceeding absolute maximum ratings can cause the over current protection circuit to not operate properly or IC breakdown before operation. In addition, depending on the method of use and usage conditions, if over current continues to flow for a long time after operation, the IC may generate heat resulting in breakdown.

(2) Thermal Shutdown Circuit

Thermal shutdown circuits do not necessarily protect ICs under all circumstances. If the thermal shutdown circuits operate against the over temperature, clear the heat generation status immediately. Depending on the method of use and usage conditions, such as exceeding absolute maximum ratings can cause the thermal shutdown circuit to not operate properly or IC breakdown before operation.

(3) Heat Radiation Design

In using an IC with large current flow such as power amp, regulator or driver, please design the device so that heat is appropriately radiated, not to exceed the specified junction temperature (T_j) at any time and condition. These ICs generate heat even during normal use. An inadequate IC heat radiation design can lead to decrease in IC life, deterioration of IC characteristics or IC breakdown. In addition, please design the device taking into consideration the effect of IC heat radiation with peripheral components.

(4) Back-EMF

When a motor rotates in the reverse direction, stops or slows down abruptly, a current flow back to the motor's power supply due to the effect of back-EMF. If the current sink capability of the power supply is small, the device's motor power supply and output pins might be exposed to conditions beyond absolute maximum ratings. To avoid this problem, take the effect of back-EMF into consideration in system design.

RESTRICTIONS ON PRODUCT USE

Toshiba Corporation and its subsidiaries and affiliates are collectively referred to as "TOSHIBA". Hardware, software and systems described in this document are collectively referred to as "Product".

- TOSHIBA reserves the right to make changes to the information in this document and related Product without notice.
- This document and any information herein may not be reproduced without prior written permission from TOSHIBA. Even with TOSHIBA's written permission, reproduction is permissible only if reproduction is without alteration/omission.
- Though TOSHIBA works continually to improve Product's quality and reliability, Product can malfunction or fail. Customers are responsible for complying with safety standards and for providing adequate designs and safeguards for their hardware, software and systems which minimize risk and avoid situations in which a malfunction or failure of Product could cause loss of human life, bodily injury or damage to property, including data loss or corruption. Before customers use the Product, create designs including the Product, or incorporate the Product into their own applications, customers must also refer to and comply with (a) the latest versions of all relevant TOSHIBA information, including without limitation, this document, the specifications, the data sheets and application notes for Product and the precautions and conditions set forth in the "TOSHIBA Semiconductor Reliability Handbook" and (b) the instructions for the application with which the Product will be used with or for. Customers are solely responsible for all aspects of their own product design or applications, including but not limited to (a) determining the appropriateness of the use of this Product in such design or applications; (b) evaluating and determining the applicability of any information contained in this document, or in charts, diagrams, programs, algorithms, sample application circuits, or any other referenced documents; and (c) validating all operating parameters for such designs and applications. **TOSHIBA ASSUMES NO LIABILITY FOR CUSTOMERS' PRODUCT DESIGN OR APPLICATIONS.**
- **PRODUCT IS NEITHER INTENDED NOR WARRANTED FOR USE IN EQUIPMENTS OR SYSTEMS THAT REQUIRE EXTRAORDINARILY HIGH LEVELS OF QUALITY AND/OR RELIABILITY, AND/OR A MALFUNCTION OR FAILURE OF WHICH MAY CAUSE LOSS OF HUMAN LIFE, BODILY INJURY, SERIOUS PROPERTY DAMAGE AND/OR SERIOUS PUBLIC IMPACT ("UNINTENDED USE").** Except for specific applications as expressly stated in this document, Unintended Use includes, without limitation, equipment used in nuclear facilities, equipment used in the aerospace industry, lifesaving and/or life supporting medical equipment, equipment used for automobiles, trains, ships and other transportation, traffic signaling equipment, equipment used to control combustions or explosions, safety devices, elevators and escalators, and devices related to power plant. **IF YOU USE PRODUCT FOR UNINTENDED USE, TOSHIBA ASSUMES NO LIABILITY FOR PRODUCT.** For details, please contact your TOSHIBA sales representative or contact us via our website.
- Do not disassemble, analyze, reverse-engineer, alter, modify, translate or copy Product, whether in whole or in part.
- Product shall not be used for or incorporated into any products or systems whose manufacture, use, or sale is prohibited under any applicable laws or regulations.
- The information contained herein is presented only as guidance for Product use. No responsibility is assumed by TOSHIBA for any infringement of patents or any other intellectual property rights of third parties that may result from the use of Product. No license to any intellectual property right is granted by this document, whether express or implied, by estoppel or otherwise.
- **ABSENT A WRITTEN SIGNED AGREEMENT, EXCEPT AS PROVIDED IN THE RELEVANT TERMS AND CONDITIONS OF SALE FOR PRODUCT, AND TO THE MAXIMUM EXTENT ALLOWABLE BY LAW, TOSHIBA (1) ASSUMES NO LIABILITY WHATSOEVER, INCLUDING WITHOUT LIMITATION, INDIRECT, CONSEQUENTIAL, SPECIAL, OR INCIDENTAL DAMAGES OR LOSS, INCLUDING WITHOUT LIMITATION, LOSS OF PROFITS, LOSS OF OPPORTUNITIES, BUSINESS INTERRUPTION AND LOSS OF DATA, AND (2) DISCLAIMS ANY AND ALL EXPRESS OR IMPLIED WARRANTIES AND CONDITIONS RELATED TO SALE, USE OF PRODUCT, OR INFORMATION, INCLUDING WARRANTIES OR CONDITIONS OF MERCHANTABILITY, FITNESS FOR A PARTICULAR PURPOSE, ACCURACY OF INFORMATION, OR NONINFRINGEMENT.**
- Do not use or otherwise make available Product or related software or technology for any military purposes, including without limitation, for the design, development, use, stockpiling or manufacturing of nuclear, chemical, or biological weapons or missile technology products (mass destruction weapons). Product and related software and technology may be controlled under the applicable export laws and regulations including, without limitation, the Japanese Foreign Exchange and Foreign Trade Law and the U.S. Export Administration Regulations. Export and re-export of Product or related software or technology are strictly prohibited except in compliance with all applicable export laws and regulations.
- Please contact your TOSHIBA sales representative for details as to environmental matters such as the RoHS compatibility of Product. Please use Product in compliance with all applicable laws and regulations that regulate the inclusion or use of controlled substances, including without limitation, the EU RoHS Directive. **TOSHIBA ASSUMES NO LIABILITY FOR DAMAGES OR LOSSES OCCURRING AS A RESULT OF NONCOMPLIANCE WITH APPLICABLE LAWS AND REGULATIONS.**

TOSHIBA ELECTRONIC DEVICES & STORAGE CORPORATION

<https://toshiba.semicon-storage.com/>