

LBZX84C27LT1G

S-LBZX84C27LT1G

Zener Voltage Regulator Diodes

1. FEATURES

- We declare that the material of product compliance with RoHS requirements and Halogen Free.
- S- prefix for automotive and other applications requiring unique site and control change requirements; AEC-Q101 qualified and PPAP capable.

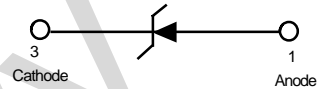
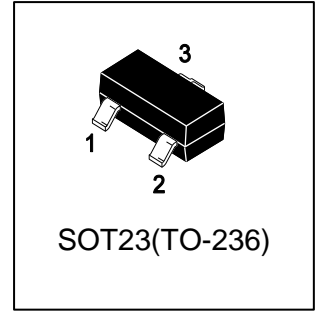

2. DEVICE MARKING AND ORDERING INFORMATION

Device	Marking	Shipping
LBZX84C27LT1G	Y10	3000/Tape&Reel
LBZX84C27LT3G	Y10	10000/Tape&Reel

3. THERMAL CHARACTERISTICS

Parameter	Symbol	Limits	Unit
Total Device Dissipation, FR-5 Board (Note 1) @ TA = 25°C Derate above 25°C	PD	225 1.8	mW mW/°C
Thermal Resistance Junction-to-Ambient	RθJA	556	°C/W
Total Device Dissipation, Alumina Substrate (Note 2) @ TA = 25°C Derate above 25°C	PD	300 2.4	mW mW/°C
Thermal Resistance Junction-to-Ambient	RθJA	417	°C/W
Junction and Storage temperature	TJ,Tstg	-55 ~ +150	°C

1.FR-5 = 1.0 × 0.75 × 0.062 in.

2.Alumina = 0.4 × 0.3 × 0.024 in. 99.5% alumina.

4. ELECTRICAL CHARACTERISTICS (Ta= 25°C)

Characteristic	Symbol	Min.	Typ.	Max.	Unit
Zener Voltage(Note 3) (IZT1 = 2 mA) (IZT2 = 0.1 mA) (IZT3 = 10 mA)	VZ	25.1 25 25.2	27 - -	28.9 28.9 29.3	V
Zener Impedance (IZT1 = 2 mA) (IZT2 = 0.5 mA) (IZT3 = 10 mA)	ZZT	- - -	- - -	80 300 45	Ω
Reverse Leakage Current (VR=18.9V)	IR	-	-	0.05	μA
Capacitance (VR=0,f=1MHz)	C	-	70	-	pF
Temperature Coefficient (IZT1 = 2mA)	θVZ	21.4	-	25.3	mV/k

3.Zener voltage is measured with a pulse test current IZ at an ambient temperature of 25°C.

Preliminary

5.OUTLINE AND DIMENSIONS

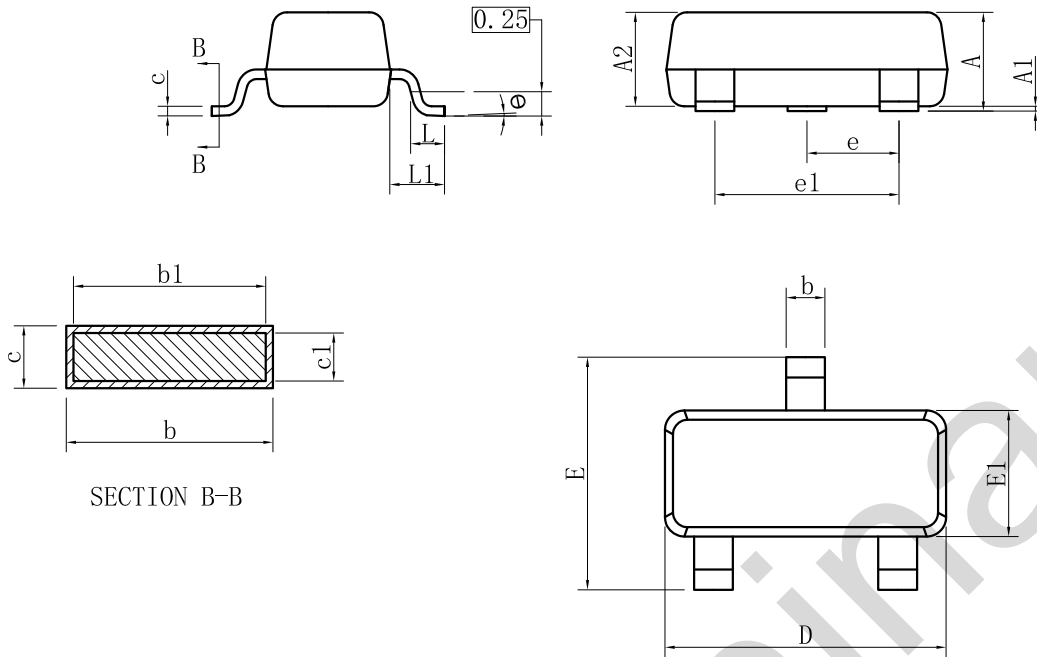

SOT23			
DIM	MIN	NOR	MAX
A	0.89	-	1.12
A1	0.01	-	0.10
A2	0.88	0.95	1.02
b	0.30	-	0.50
b1	0.30	0.40	0.45
c	0.08	-	0.20
c1	0.08	0.10	0.16
D	2.80	2.90	3.04
E	2.10	-	2.64
E1	1.20	1.30	1.40
e	0.95BSC		
e1	1.90BSC		
L	0.40	0.46	0.60
L1	0.54REF		
θ	0°	-	8°
All Dimensions in mm			

GENERAL NOTES

- 1.Top package surface finish Ra0.4±0.2um
- 2.Bottom package surface finish Ra0.7±0.2um
- 3.Side package surface finish Ra0.4±0.2um

6.SOLDERING FOOTPRINT

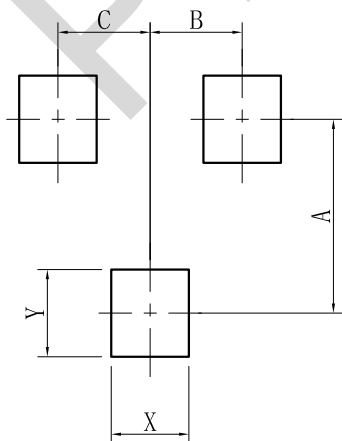

SOT-23	
DIM	(mm)
X	0.80
Y	0.90
A	2.00
B	0.95
C	0.95

DISCLAIMER

- Curve guarantee in the specification. The curve of test items with electric parameter is used as quality guarantee. The curve of test items without electric parameter is used as reference only.
- Before you use our Products for new Project, you are requested to carefully read this document and fully understand its contents. LRC shall not be in any way responsible or liable for failure, malfunction or accident arising from the use of any LRC's Products against warning, caution or note contained in this document.
- All information contained in this document is current as of the issuing date and subject to change without any prior notice. Before purchasing or using LRC's Products, please confirm the latest information with a LRC sales representative.
- First edition: The information contained in this document is provided on an "as is" basis and LRC does not warrant that all information contained in this document is accurate and/or error-free. LRC shall not be in any way responsible or liable for any damages, expenses or losses incurred by you or third parties resulting from inaccuracy or errors of or concerning such information.

Preliminary