

A B C D E

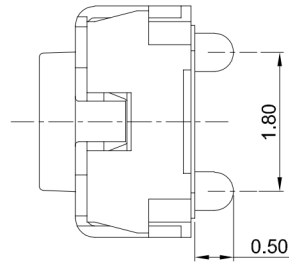
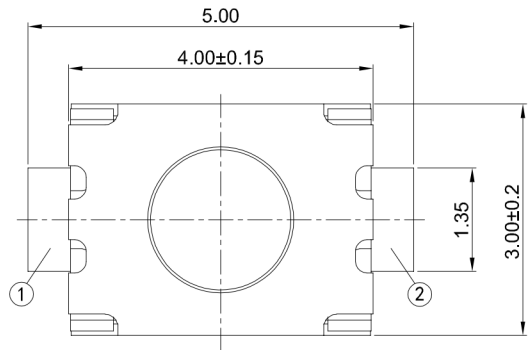

GT-TC029A-H040-L1 A

G-Switch

Operating Force

- A=160gf
- B=250gf
- C=100gf
- D=400gf

DETAIL

- A=Base With Pilot
- N=Non Pilot

Switch Height

- H020=2.0mm
- H025=2.5mm
- H030=3.0mm
- H040=4.0mm

Switch Lifetime (Force)
L1=100,000 Cycles

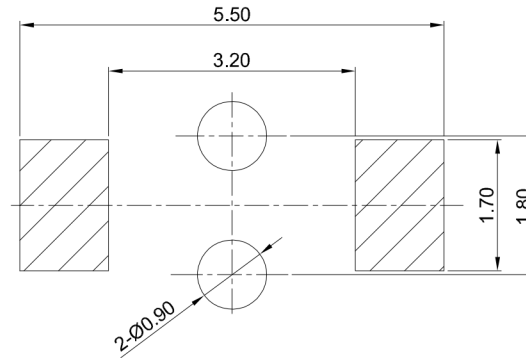
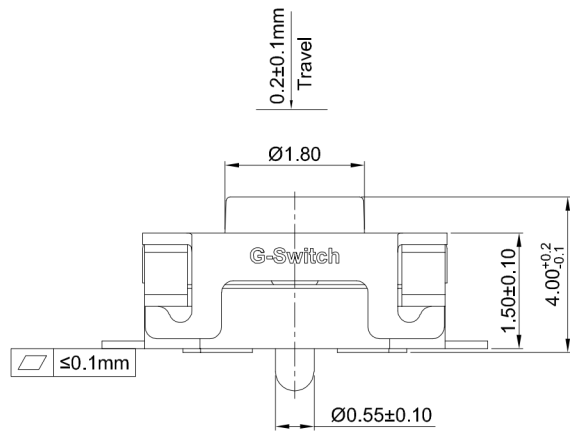

RECOMMENDED PCB LAYOUT
TOLERANCE:±0.05

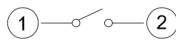

CIRCUIT DIAGRAM

G-Switch Specification:

1. Operating temperature range: -40°C ~ +85°C
2. Rating: 50mA, 12V DC
3. Insulation resistance: 100MΩ min, 100V DC
4. Dielectric strength: 250V AC for 1 min
5. Contact resistance: 100mΩ max.
6. Travel: 0.20±0.1mm

6	STEM	C2680	
5	COVER	STAINLESS STEEL	
4	TAPE	POLYIMIDE	
3	CONTACT	STAINLESS STEEL	Ag PLATING
2	TERMINAL	COPPER ALLOY	Ag PLATING
1	CASE	HIGH TEMPERATURE PLASTIC	
NO.	PART NAME	MATERIAL	REMARK



RoHS
Compliant
EU RoHS Standards



SCALE: 1:1 UNIT: mm
SIZE: A4

Unless otherwise
General Tolerance:
X. ±0.40
X.x ±0.30
X.xx ±0.20
X* ±5°
X.x* ±3°

Title: Vertical Tact Switch
SMT Flat Terminal 4.0×3.0×4.0mm

Molde Code: GT-TC029A-H040-L1A

DRAWN	CHECKED	APPROVED	DATE
Xia	Chen	Chen	2023.02.01



REV: A0 SHEET: 1/1

A B C D E