

MMDTA234

PNP Silicon Epitaxial Planar Transistor

for high current switching, interface circuit and driver circuit application.

Feature

- With built-in bias resistor
- Simplify circuit design
- Reduce a quantity of parts and manufacturing process
- High output current

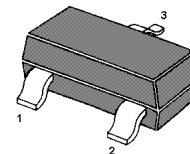
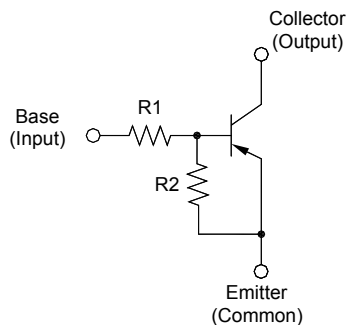

1. Base 2. Emitter 3. Collector
TO-236 Plastic Package

Resistance Values

Type	R1 (KΩ)	R2 (KΩ)
MMDTA234	2.2	10

Absolute Maximum Ratings ($T_a = 25\text{ }^\circ\text{C}$)

Parameter	Symbol	Value	Unit
Collector Emitter Voltage	$-V_{CEO}$	50	V
Emitter Base Voltage	$-V_{EBO}$	- 6 to + 12	V
Collector Current ¹⁾	$-I_C$	800	mA
Total Power Dissipation	P_{tot}	200	mW
Junction Temperature	T_j	150	$^\circ\text{C}$
Storage Temperature Range	T_{Stg}	- 55 to + 150	$^\circ\text{C}$

¹⁾ $t_p = 1\text{mS}$.

Characteristics at $T_a = 25\text{ }^\circ\text{C}$

Parameter	Symbol	Min.	Typ.	Max.	Unit
DC Current Gain at $-V_{CE} = 5\text{ V}$, $-I_C = 50\text{ mA}$	h_{FE}	56	-	-	-
Collector Base Cutoff Current at $-V_{CB} = 30\text{ V}$	$-I_{CBO}$	-	-	10	μA
Emitter Base Cutoff Current at $-V_{EB} = 5\text{ V}$	$-I_{EBO}$	-	-	3.6	mA
Collector Emitter Saturation Voltage at $I_C = 50\text{ mA}$, $I_B = 2.5\text{ mA}$	$-V_{CEsat}$	-	-	0.3	V
Input Off Voltage at $-V_{CE} = 5\text{ V}$, $-I_C = 0.1\text{ mA}$	$-V_{I(off)}$	0.3	-	-	V
Input On Voltage at $-V_{CE} = 0.3\text{ V}$, $-I_C = 20\text{ mA}$	$-V_{I(on)}$	-	-	2	V
Transition Frequency at $-V_{CE} = 10\text{ V}$, $-I_E = 5\text{ mA}$, $f = 100\text{ MHz}$	f_T ¹⁾	-	200	-	MHz

¹⁾ Characteristic of transistor only.

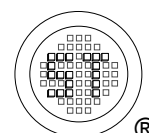

MMDTA234

