



CA139, CA239, CA339 LM339, LM2901, LM3302

Quad Voltage Comparators for Industrial,
Commercial and Military Applications

September 1993

Features

- Operation from Single or Dual Supplies
- Common Mode Input Voltage Range to GND
- Output Voltage Compatible with TTL, DTL, ECL, MOS and CMOS
- Differential Input Voltage Range Equal to the Supply Voltage
- Maximum Input Offset Voltage (V_{IO})
 - CA139A, CA239A, CA339A 2mV
 - CA139, CA239, CA339 5mV
 - LM2901 7mV
 - LM3302 20mV
- Replacement for Industry Types 139, 239, 339, 139A, 239A, 339A, 2901, 3302

Applications

- Square Wave Generator
- Time Delay Generators
- Pulse Generators
- Multivibrators
- High Voltage Digital Logic Gates
- A/D Converters
- MOS Clock Timers

Description

The devices in this series consist of four independent single or dual supply voltage comparators on a single monolithic substrate. The common mode input voltage range includes ground even when operated from a single supply, and the low power supply current drain makes these comparators suitable for battery operation. These types were designed to directly interface with TTL and CMOS.

Types CA139A, CA239A, and CA339A have all the features and characteristics of their prototype counterparts CA139, CA239, and CA339 plus an even lower input offset voltage characteristic. All the SOIC parts are available on tape and reel. Replace the M suffix in the part number with M96 when ordering (e.g. CA0339AM96). The CA339 is also available in chip form (H suffix).

Ordering Information

PART NUMBER	TEMPERATURE RANGE	PACKAGE
CA0139E, AE	-55°C to +125°C	14 Lead Plastic DIP
CA0139F, AF	-55°C to +125°C	14 Lead Ceramic DIP
CA0139M, AM	-55°C to +125°C	14 Lead SOIC
CA0239E, AE	-25°C to +85°C	14 Lead Plastic DIP
CA0239F, AF	-25°C to +85°C	14 Lead Ceramic DIP
CA0239M, AM	-25°C to +85°C	14 Lead SOIC
CA0339E, AE	0°C to +70°C	14 Lead Plastic DIP
CA0339F, AF	0°C to +70°C	14 Lead Ceramic DIP
CA0339M, AM	0°C to +70°C	14 Lead SOIC
LM339N, AN	0°C to +70°C	14 Lead Plastic DIP
LM2901M	-40°C to +85°C	14 Lead SOIC
LM2901N	-40°C to +85°C	14 Lead Plastic DIP
LM3302M	-40°C to +85°C	14 Lead SOIC
LM3302N	-40°C to +85°C	14 Lead Plastic DIP

Pinout

CA139, CA139A, CA239, CA239A, CA339 (PDIP, CDIP, SOIC)
CA339A, LM2901, LM3302 (PDIP, SOIC)
LM339, LM339A (PDIP)
TOP VIEW

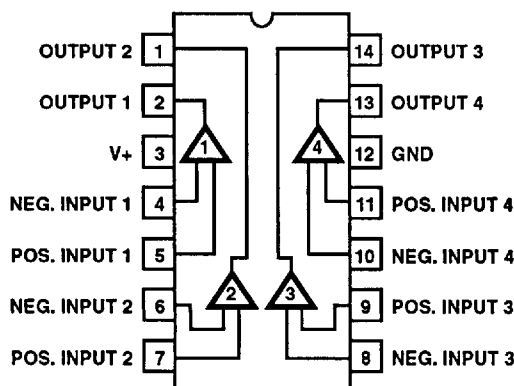

Schematic Diagram

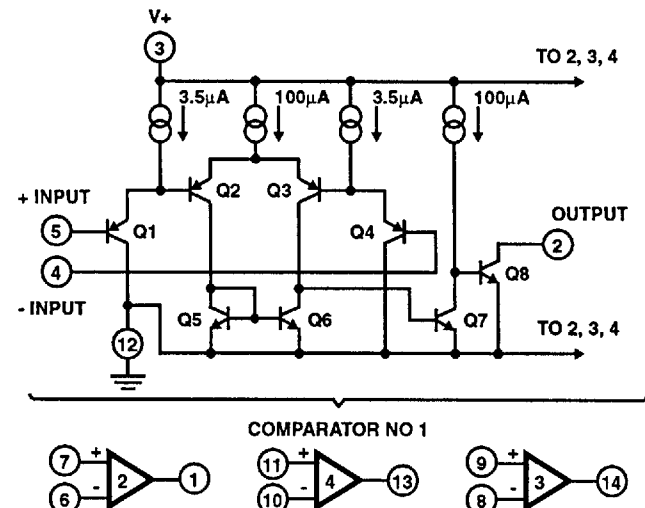

Specifications CA139, CA139A, CA239, CA239A, CA339, CA339A, LM339, LM339A, LM2901, LM3302

Absolute Maximum Ratings

Supply Voltage	36V or ±18V
Differential Input Voltage	36V
Input Voltage	-0.3V to +36V
Input Current ($V_I < -0.3V$) Note 4	50mA
Output Short Circuit Duration (Single Supply) Note 5	Continuous
Junction Temperature	+175°C
Junction Temperature (Plastic Package)	+150°C
Lead Temperature (Soldering 10 Sec.)	+300°C

Operating Conditions

Operating Temperature Range	-55°C to +125°C	
Storage Temperature Range	-65°C to +150°C	
Thermal Package Characteristics (°C/W)	θ_{JA}	θ_{JC}
Ceramic DIP Package	71	14
Plastic DIP Package	107	38
SOIC Package	119	36

CAUTION: Stresses above those listed in "Absolute Maximum Ratings" may cause permanent damage to the device. This is a stress only rating and operation of the device at these or any other conditions above those indicated in the operational sections of this specification is not implied.

Electrical Specifications $V_+ = 5V$, Unless Otherwise Specified

PARAMETER	SYMBOL	CONDITION	LIMITS						UNITS	
			CA139			CA139A				
			MIN	TYP	MAX	MIN	TYP	MAX		
Input Offset Voltage	V_{IO}	$V_{REF} = 1.4V, R_S = 0, \text{ Output Switch Point } V \equiv 1.4V$	$T_A = +25^\circ C$	-	2	5	-	1	2	mV
			Note 1	-	-	9	-	-	4	mV
Differential Input Voltage	V_{ID}	Keep All Inputs $\geq 0V$ for V_- (if used), Notes 1, 2	-	-	36	-	-	36	V	
Saturation Voltage	V_{SAT}	$V_I = 1V, V_{I+} = 0V, I_{SINK} \leq 4mA$	$T_A = +25^\circ C$	-	250	400	-	250	400	mV
			Note 1	-	-	700	-	-	700	mV
Common Mode Input Voltage Range	V_{ICR}	Note 3	$T_A = +25^\circ C$	0	-	$V_+ - 1.5$	0	-	$V_+ - 1.5$	V
			Note 1	0	-	$V_+ - 2$	0	-	$V_+ - 2$	V
Input Offset Current	I_{IO}	$I_{I+} - I_{I-}$	$T_A = +25^\circ C$	-	3	25	-	3	25	nA
			Note 1	-	-	100	-	-	100	nA
Input Bias Current	I_{IB}	I_{I+} or I_{I-} with Output in Linear Range	$T_A = +25^\circ C$	-	25	100	-	25	100	nA
			Note 1	-	-	300	-	-	300	nA
Total Supply Current	I_+	$R_L = \infty$ on All Comparators, $T_A = +25^\circ C$	-	0.8	2	-	0.8	2	mA	
Output Leakage Current		$V_{I+} \geq 1V, V_{I-} = 0V, V_O = 5V$	$T_A = +25^\circ C$	-	0.1	-	-	0.1	-	nA
		$V_{I+} \geq 1V, V_{I-} = 0V, V_O = 30V$	Note 1	-	-	1	-	-	1	μA
Output Sink Current		$V_{I-} \geq 1V, V_{I+} = 0V, V_O \leq 1.5V, T_A = +25^\circ C$	6	16	-	6	16	-	mA	
Voltage Gain	A_{OL}	$R_L \geq 15k\Omega, V_+ = 15V, T_A = +25^\circ C$	-	200	-	50	200	-	V/mV	
Large Signal Response Time		$V_I = \text{TTL Logic Swing}, V_{REF} = 1.4V, V_{RL} = 5V, R_L = 5.1k\Omega, T_A = +25^\circ C$	-	300	-	-	300	-	ns	
Response Time (Figures 3 and 4)		$V_{RL} = 5V, R_L = 5.1k\Omega, T_A = +25^\circ C$	-	1.3	-	-	1.3	-	μs	

Specifications CA139, CA139A, CA239, CA239A, CA339, CA339A, LM339, LM339A, LM2901, LM3302

Electrical Specifications $V_+ = 5V$, Unless Otherwise Specified

PARAMETER	SYMBOL	CONDITION	LIMITS						UNITS	
			CA239, CA339, LM339			CA239A, CA339A, LM339A				
			MIN	TYP	MAX	MIN	TYP	MAX		
Input Offset Voltage	V_{IO}	$V_{REF} = 1.4V, R_S = 0,$ Output Switch Point $V \equiv 1.4V$	$T_A = +25^\circ C$	-	2	5	-	1	2	mV
			Note 1	-	-	9	-	-	4	mV
Differential Input Voltage	V_{ID}	Keep All Inputs $\geq 0V$ for V- (if used), Notes 1, 2		-	-	36	-	-	36	V
Saturation Voltage	V_{SAT}	$V_{I-} = 1V, V_{I+} = 0V,$ $I_{SINK} \leq 4mA$	$T_A = +25^\circ C$	-	250	400	-	250	400	mV
			Note 1	-	-	700	-	-	700	mV
Common Mode Input Voltage Range	V_{ICR}	Note 3	$T_A = +25^\circ C$	0	-	$V_+ - 1.5$	0	-	$V_+ - 1.5$	V
			Note 1	0	-	$V_+ - 2$	0	-	$V_+ - 2$	V
Input Offset Current	I_{IO}	$I_{I+} - I_{I-}$	$T_A = +25^\circ C$	-	5	50	-	5	50	nA
			Note 1	-	-	150	-	-	150	nA
Input Bias Current	I_{IB}	I_{I+} or I_{I-} with Output in Linear Range	$T_A = +25^\circ C$	-	25	250	-	25	250	nA
			Note 1	-	-	400	-	-	400	nA
Total Supply Current	I_+	$R_L = \infty$ on All Comparators, $T_A = +25^\circ C$		-	0.8	2	-	0.8	2	mA
Output Leakage Current		$V_{I+} \geq 1V, V_{I-} = 0V,$ $V_O = 5V$	$T_A = +25^\circ C$	-	0.1	-	-	0.1	-	nA
		$V_{I+} \geq 1V, V_{I-} = 0V,$ $V_O = 30V$	Note 1	-	-	1	-	-	1	μA
Output Sink Current		$V_{I-} \geq 1V, V_{I+} = 0V, V_O \leq 1.5V,$ $T_A = +25^\circ C$		6	16	-	6	16	-	mA
Voltage Gain	A_{OL}	$R_L \geq 15k\Omega, V_+ = 15V, T_A = +25^\circ C$		50	200	-	50	200	-	V/mV
Large Signal Response Time		$V_I =$ TTL Logic Swing, $V_{REF} = 1.4V,$ $V_{RL} = 5V, R_L = 5.1k\Omega, T_A = +25^\circ C$		-	300	-	-	300	-	ns
Response Time (Figures 3 and 4)		$V_{RL} = 5V, R_L = 5.1k\Omega, T_A = +25^\circ C$		-	1.3	-	-	1.3	-	μs

NOTES:

1. Ambient Temperature (T_A) applicable over operating temperature range as shown below.
CA139, CA139A = $-55^\circ C$ to $+125^\circ C$; CA239, CA239A = $-25^\circ C$ to $+85^\circ C$; CA339, CA339A, LM339, LM339A = $0^\circ C$ to $+70^\circ C$; LM2901, LM3302 = $-40^\circ C$ to $+85^\circ C$.
2. The comparator will provide a proper output state even if the positive swing of the inputs exceeds the power supply voltage level, if the other input remains within the common mode voltage range. The low input voltage state must not be less than $-0.3V$ (or $0.3V$ below the magnitude of the negative power supply, if used).
3. The upper end of the common mode voltage range is $(V_+) - 1.5V$, but either or both inputs can go to $+30V$ without damage.
4. Inputs must not go more negative than $-0.3V$.
5. Short circuits from the output to V_+ can cause excessive heating and eventual destruction. The maximum output current independent of V_+ is approximately 20mA.

Specifications CA139, CA139A, CA239, CA239A, CA339, CA339A, LM339, LM339A, LM2901, LM3302

Electrical Specifications $V_+ = 5V$, Unless Otherwise Specified

PARAMETER	SYMBOL	CONDITION	LIMITS						UNITS	
			LM2901			LM3302				
			MIN	TYP	MAX	MIN	TYP	MAX		
Input Offset Voltage	V_{IO}	$V_{REF} = 1.4V, R_S = 0,$ Output Switch Point $V \approx 1.4V$	$T_A = +25^\circ C$	-	2	7	-	1	20	mV
			Note 1	-	-	15	-	-	40	mV
Differential Input Voltage	V_{ID}	Keep All Inputs $\geq 0V$ for V_- (if used), Notes 1, 2		-	-	36	-	-	28	V
Saturation Voltage	V_{SAT}	$V_I = 1V, V_{I+} = 0V,$ $I_{SINK} \leq 4mA$	$T_A = +25^\circ C$	-	250	400	-	250	500	mV
			Note 1	-	-	700	-	-	700	mV
Common Mode Input Voltage Range	V_{ICR}	Note 3	$T_A = +25^\circ C$	0	-	$V_+ - 1.5$	0	-	$V_+ - 1.5$	V
			Note 1	0	-	$V_+ - 2$	0	-	$V_+ - 2$	V
Input Offset Current	I_{IO}	$I_{I+} - I_{I-}$	$T_A = +25^\circ C$	-	5	50	-	3	100	nA
			Note 1	-	-	200	-	-	300	nA
Input Bias Current	I_{IB}	I_{I+} or I_{I-} with Output in Linear Range	$T_A = +25^\circ C$	-	25	250	-	25	500	nA
			Note 1	-	-	500	-	-	1000	nA
Total Supply Current	I_+	$R_L = \infty$ on All Comparators, $T_A = +25^\circ C$		-	0.8	2	-	0.8	2	mA
Output Leakage Current		$V_{I+} \geq 1V, V_{I-} = 0V,$ $V_O = 5V$	$T_A = +25^\circ C$	-	0.1	-	-	0.1	-	nA
		$V_{I+} \geq 1V, V_{I-} = 0V,$ $V_O = 30V$	Note 1	-	-	1	-	-	1	μA
Output Sink Current		$V_{I-} \geq 1V, V_{I+} = 0V, V_O \leq 1.5V,$ $T_A = +25^\circ C$		6	16	-	6	16	-	mA
Voltage Gain	A_{OL}	$R_L \geq 15k\Omega, V_+ = 15V, T_A = +25^\circ C$		25	100	-	2	30	-	V/mV
Large Signal Response Time		$V_I =$ TTL Logic Swing, $V_{REF} = 1.4V,$ $V_{RL} = 5V, R_L = 5.1k\Omega, T_A = +25^\circ C$		-	300	-	-	300	-	ns
Response Time (Figures 3 and 4)		$V_{RL} = 5V, R_L = 5.1k\Omega, T_A = +25^\circ C$		-	1.3	-	-	1.3	-	μs

Metallization Mask Layout

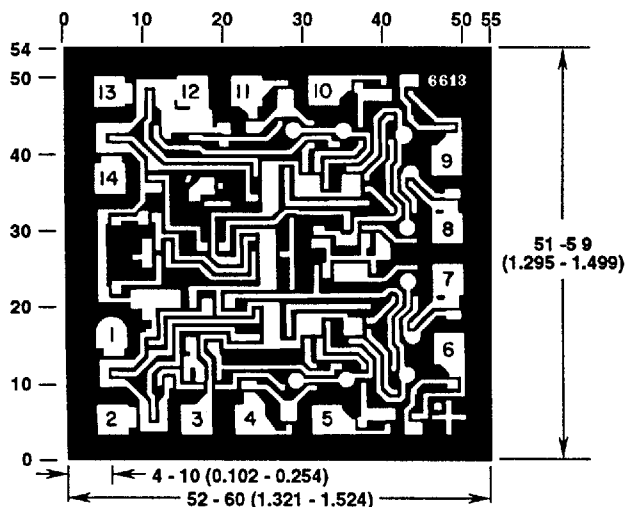

NOTE: Dimensions in parentheses are in mm and are derived from the basic in. dimensions as indicated. Grid graduations are in mils (10^{-3} inch).

CA139, CA139A, CA239, CA239A, CA339, CA339A, LM339, LM339A, LM2901, LM3302

Typical Performance Curves

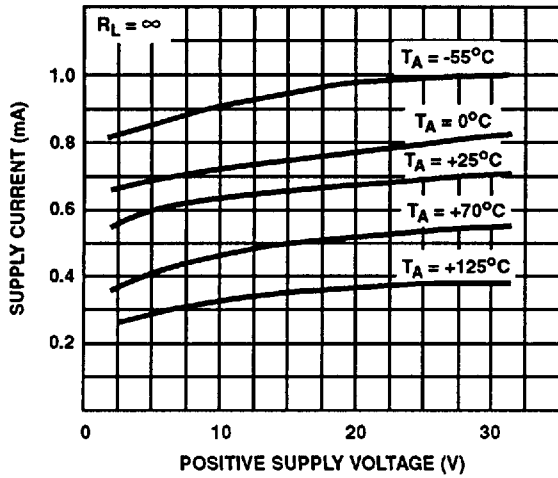

FIGURE 1. SUPPLY CURRENT vs SUPPLY VOLTAGE

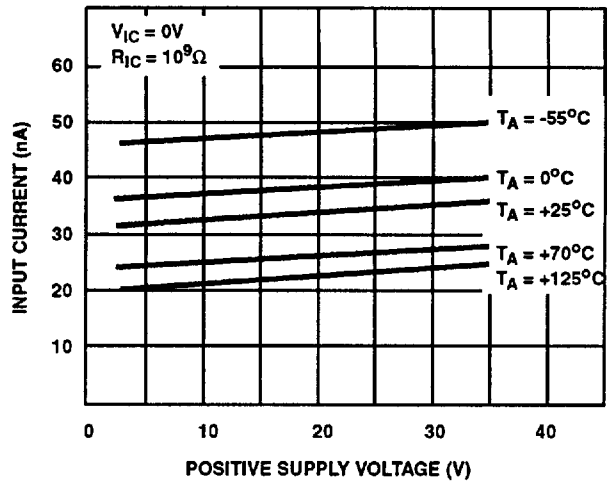

FIGURE 2. INPUT CURRENT vs SUPPLY VOLTAGE

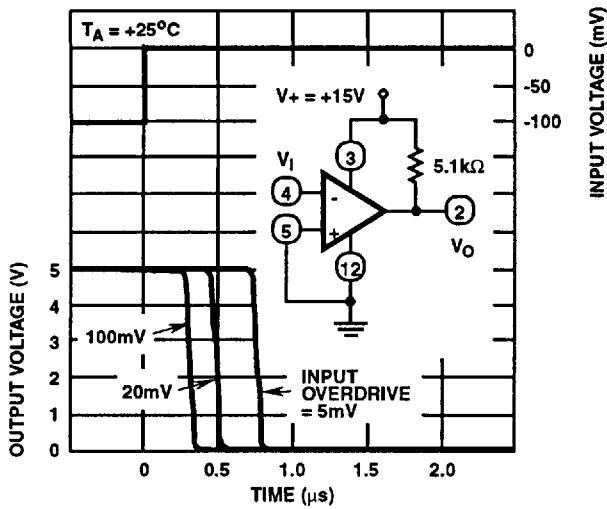

FIGURE 3. RESPONSE TIME FOR VARIOUS INPUT OVERDRIVES - NEGATIVE TRANSITION

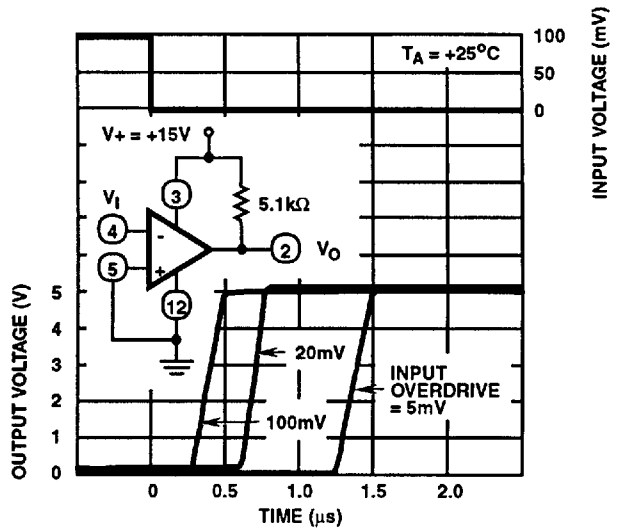

FIGURE 4. RESPONSE TIME FOR VARIOUS INPUT OVERDRIVES - POSITIVE TRANSITION

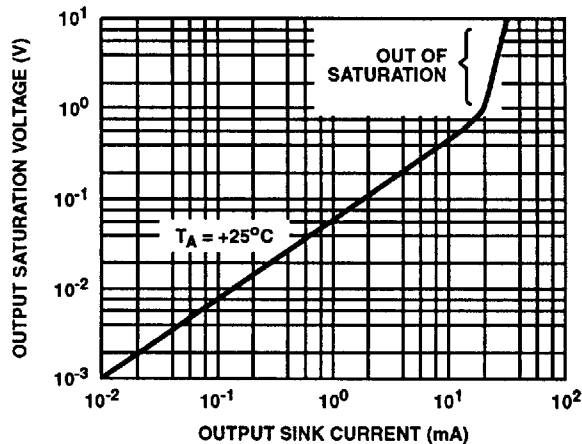

FIGURE 7. OUTPUT SATURATION VOLTAGE vs OUTPUT SINK CURRENT