

LOC		DIST		REVISIONS			
P	LTN	DESCRIPTION	DATE	DWN	APVD		
B2		REVISED PER ECO-12-011334	28SEP2012	KH	JE		

- 2 PHOSPHOR BRONZE
- 3 LCP, UL94V-0
- 4 FINISH:  
CONTACT MATING AREA MEETS THE PERFORMANCE REQUIREMENTS OF  
TE CONNECTIVITY PRODUCT SPECIFICATION 108-1957; BASED ON  
TELCORDIA GR-1217-CORE, APPLICATIONS IN UNCONTROLLED ENVIRONMENTS.  
COMPLIANT PIN AREA: 0.5µm MIN MATTE TIN OVER BASE PLATING.
- 5 CONNECTOR MARKED WITH PART NUMBER AND DATE CODE
- 6 REFERENCE APPLICATION SPEC 114-13020 FOR RECOMMENDED  
PLATED THRU HOLE DIAMETER AND PLATING THICKNESS.
- 7 APPLICATION SEATING HEIGHT TO PRINTED CIRCUIT BOARD
- 8 DATUMS AND BASIC DIMENSIONS ESTABLISHED BY CUSTOMER
- 9 LUBRICATE CONTACT AREA WITH BELLCORE APPROVED LUBRICANT  
TECHNICAL REFERENCE: GR-1217-CORE, ISSUE 1, NOVEMBER 1995
- 10 HOLE DIAMETER SHULD BE 3.10 WHEN USING FEED THROUGH GUIDE PIN P/N 120759  
CLEARANCE FOR A M3x0.5 THREAD

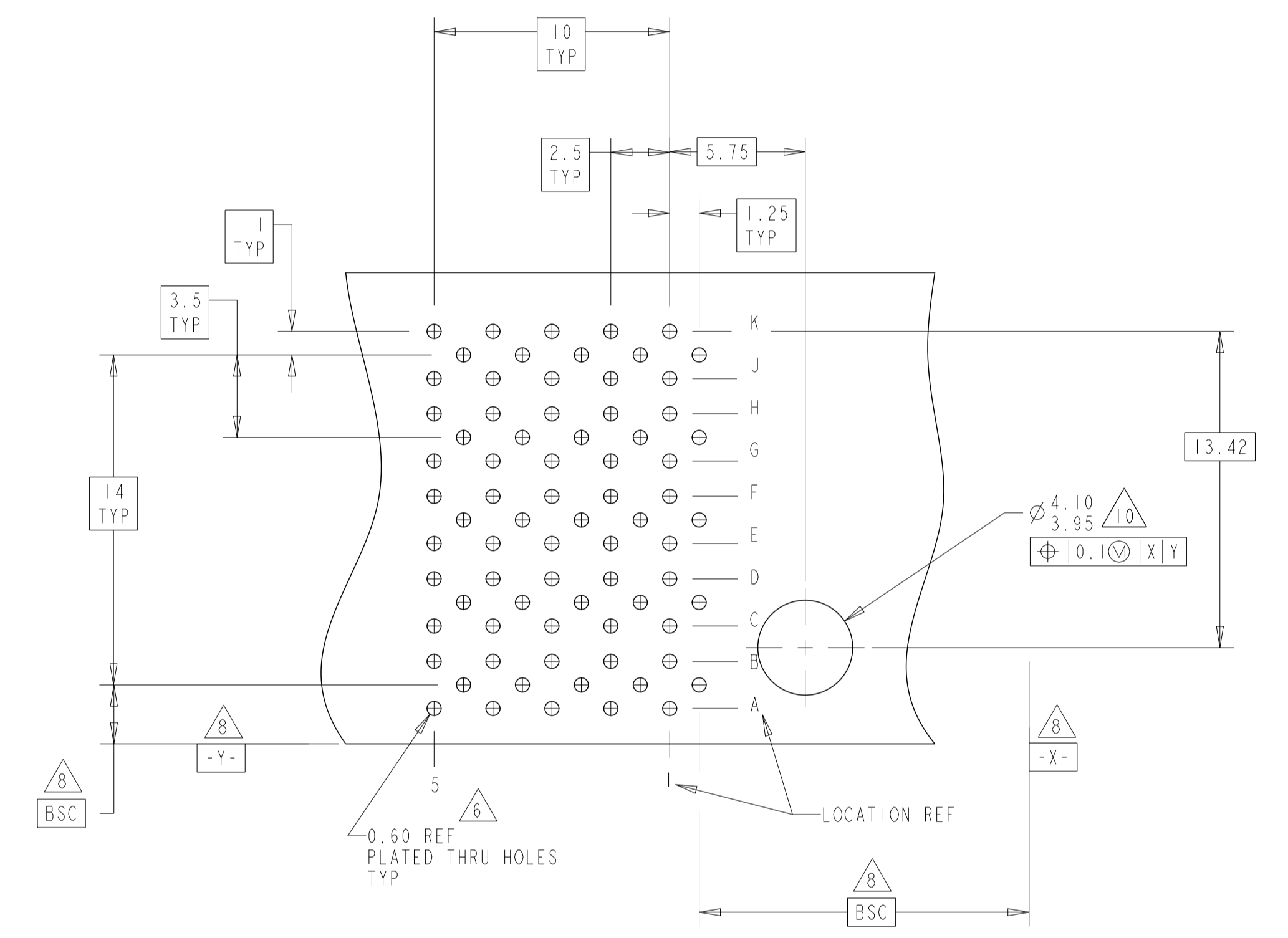

RECOMMENDED  
PRINTED CIRCUIT BOARD  
LAYOUT  
COMPONENT SIDE OF PRINTED CIRCUIT BOARD

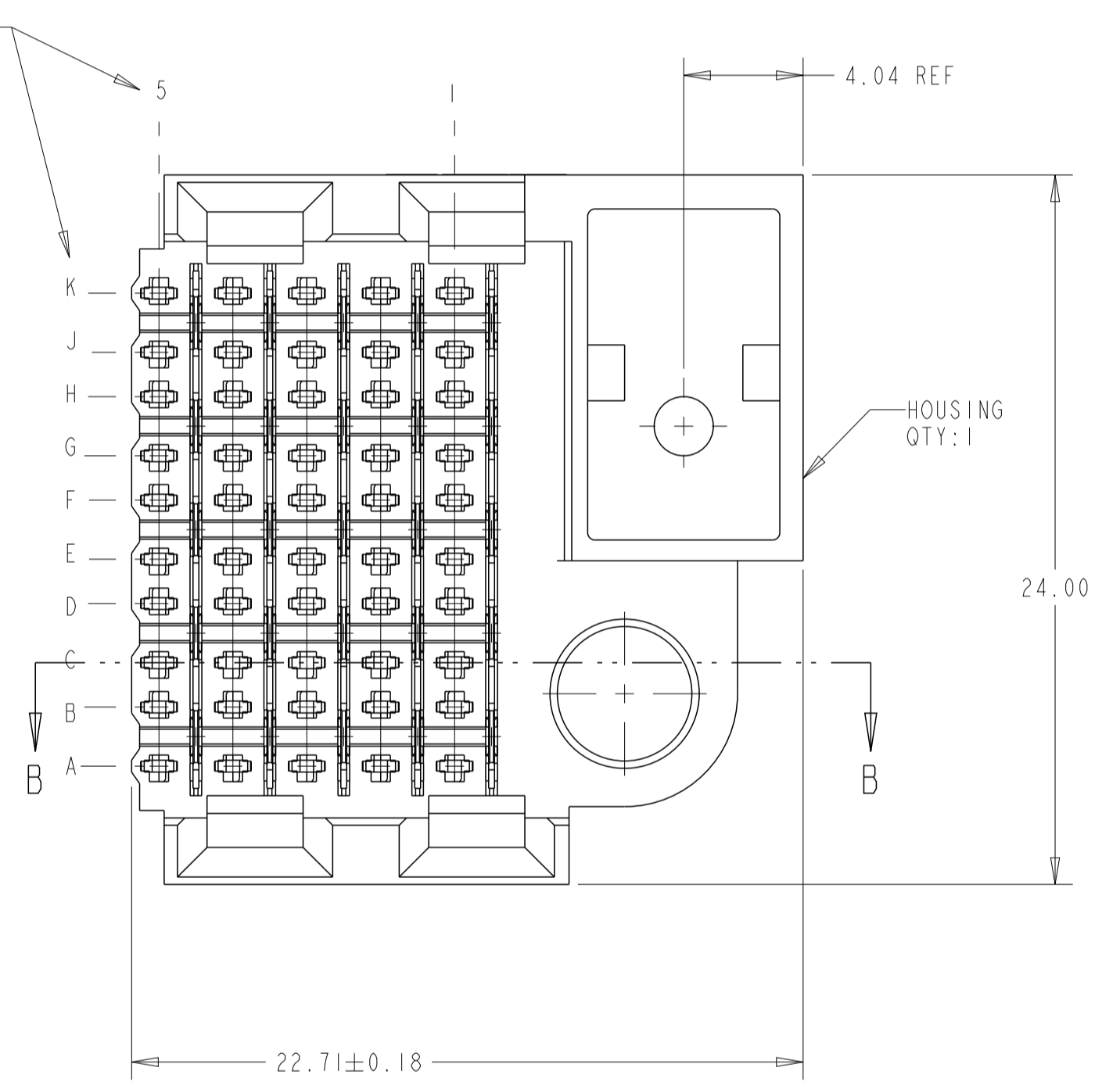
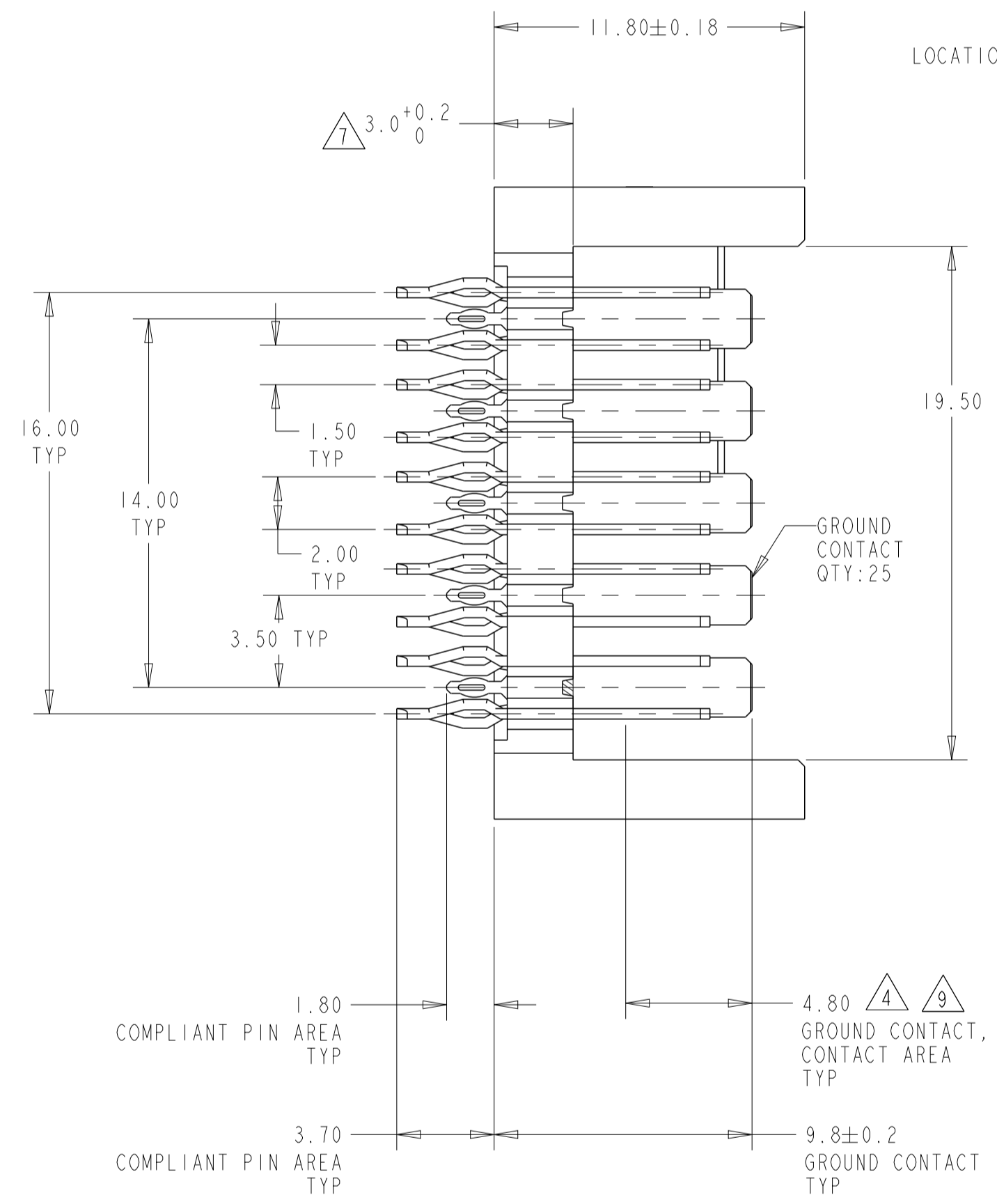
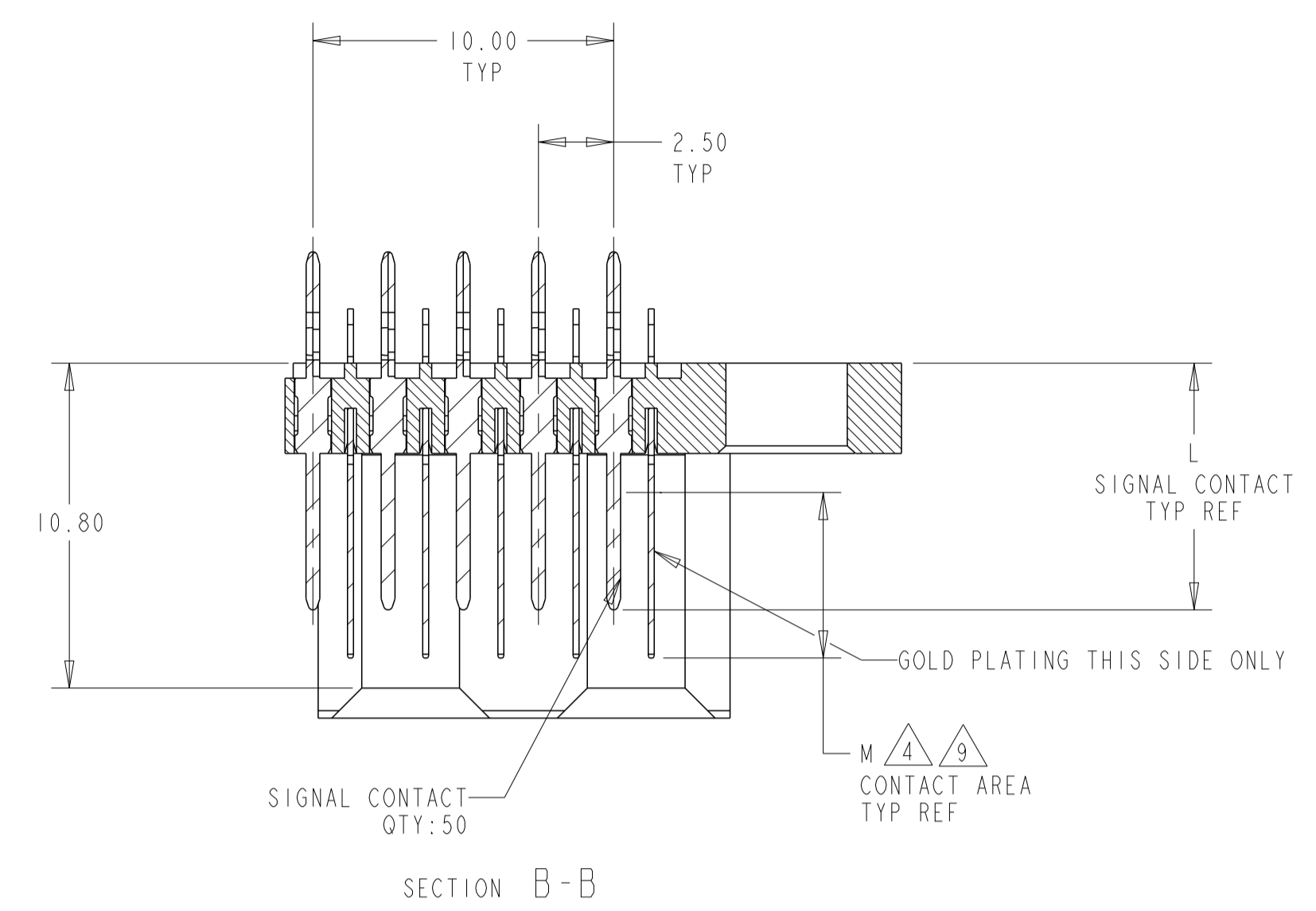
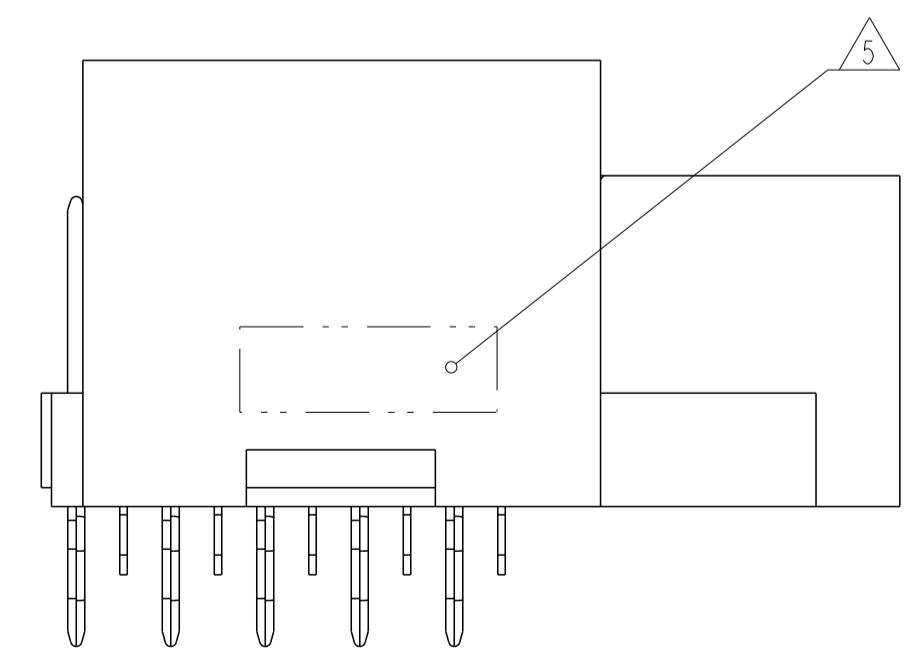

5.50	9.7	5120662-2
5.50	8.2	5120662-1
M	L	PART NUMBER

THIS DRAWING IS A CONTROLLED DOCUMENT.

DIMENSIONS:	TOLERANCES UNLESS OTHERWISE SPECIFIED:	DWN B. CARBO 06DEC04	CHK R. PATTERSON 06DEC04	APVD R. PATTERSON 06DEC04	NAME
mm	0 PLC ±	TE Connectivity			HEADER ASSEMBLY, 50 POSITION, LEFT HAND, 10 ROW, Z-PACK HS3
	1 PLC ±	SIZE	CAGE CODE	DRAWING NO	
	2 PLC ±0.13	A1	00779	5120662	
	3 PLC ±0.05	SCALE	5:1	SHEET	1
	4 PLC ±	WEIGHT		OF	1
	ANGLES ±	CUSTOMER DRAWING		REV	B2
MATERIAL HOUSING: 3	FINISH				
CONTACTS: 2	SIGNAL CONTACT: 4				