

REVISIONS					
P	LTR	DESCRIPTION	DATE	DN	APVD
L1		REVISED PER ECR-22-150475	26AUG2022	RK	MZ

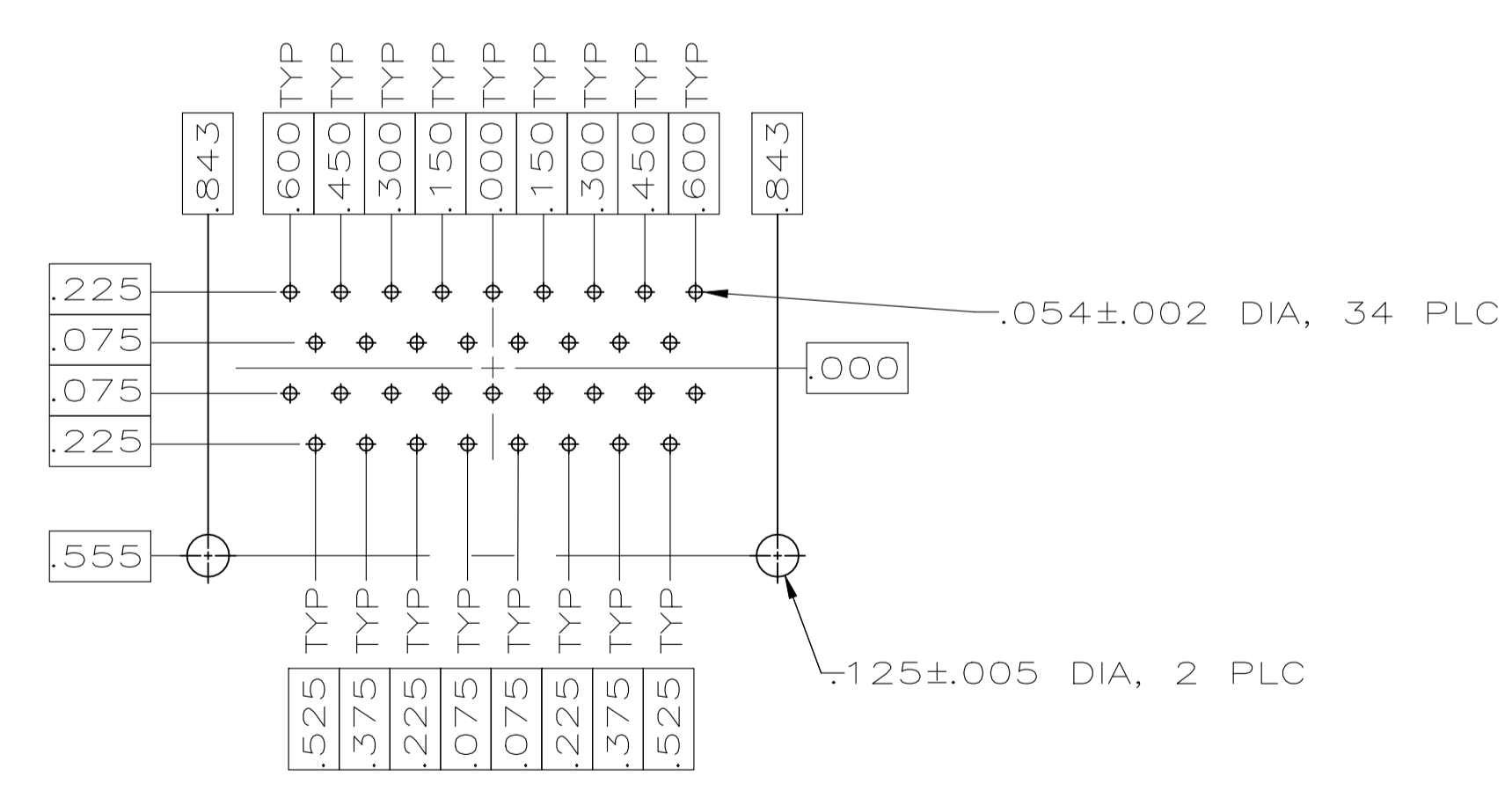
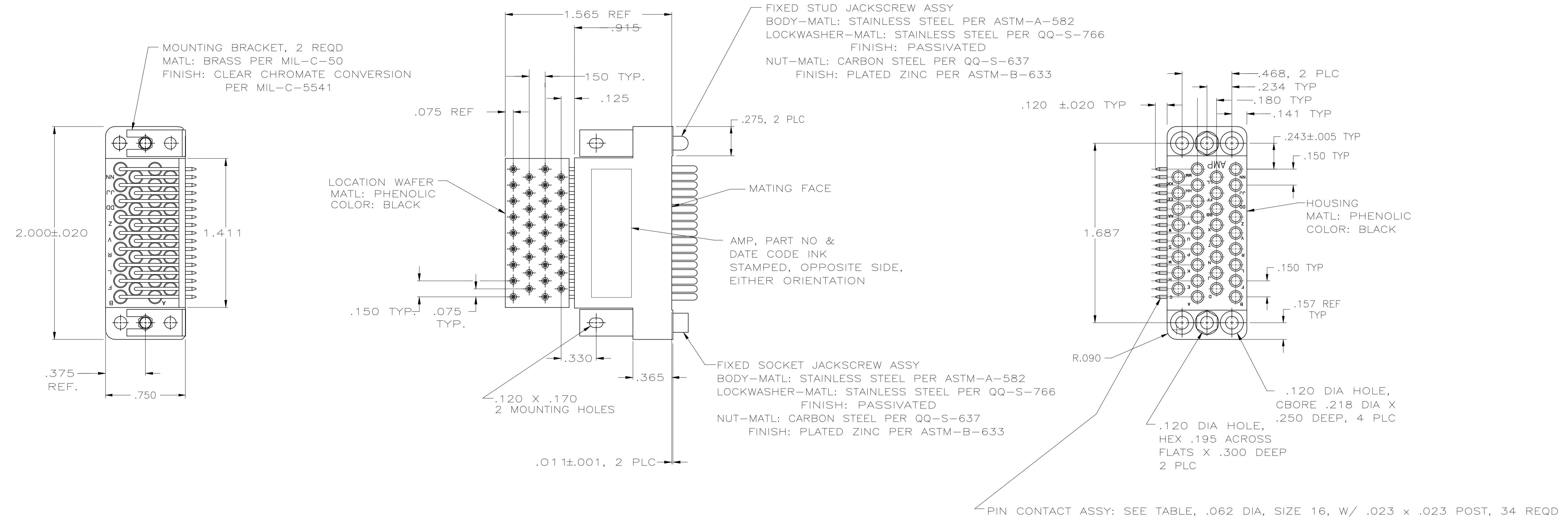

- △ BODY-MATL: BRASS PER MIL-C-50.
FINISH: PLATED GOLD .000030 THK PER MIL-G-45204 FOR A LENGTH OF .200 MIN FROM MATING END, .000100 MIN TIN-LEAD PER MIL-T-10727 IN WIRE BARREL AREA, BOTH OVER NICKEL .000050 THK PER QQ-N-290.
SPRING-MATL: STAINLESS STEEL PER QQ-S-766.
POST-MATL: BRASS PER ASTM-B-134.
FINISH: PLATED MATTE TIN-LEAD PER MIL-T-10727 OVER NICKEL .000050 THK PER QQ-N-290.
- △ BODY-MATL: BRASS PER MIL-C-50.
FINISH: PLATED GOLD .000030 THK PER MIL-G-45204 FOR A LENGTH OF .200 MIN FROM MATING END, .000100 MIN TIN PER MIL-T-10727 IN WIRE BARREL AREA, BOTH OVER NICKEL .000050 THK PER QQ-N-290.
SPRING-MATL: STAINLESS STEEL PER QQ-S-766.
POST-MATL: BRASS PER ASTM-B-134.
FINISH: PLATED MATTE TIN PER MIL-T-10727 OVER NICKEL .000050 THK PER QQ-N-290.

OBSOLETE	△	213289-2
	△	213289-1
CONTACT FINISH		PART NUMBER

THIS DRAWING IS A CONTROLLED DOCUMENT.		DIN	M. HOFFECKER	5-12-86																		
DIMENSIONS: INCHES		CHK	L. LAWVER	5-12-86																		
TOLERANCES UNLESS OTHERWISE SPECIFIED:		APVD																				
<table border="1"> <tr><td>0 PLC</td><td>±</td><td>-</td></tr> <tr><td>1 PLC</td><td>±</td><td>-</td></tr> <tr><td>2 PLC</td><td>±</td><td>-</td></tr> <tr><td>3 PLC</td><td>±</td><td>.010</td></tr> <tr><td>4 PLC</td><td>±</td><td>-</td></tr> <tr><td>ANGLES</td><td>±</td><td>-</td></tr> </table>		0 PLC	±	-	1 PLC	±	-	2 PLC	±	-	3 PLC	±	.010	4 PLC	±	-	ANGLES	±	-	NAME	CONNECTOR ASSEMBLY, PIN, 34 POSITION, RIGHT ANGLE, M SERIES	
0 PLC	±	-																				
1 PLC	±	-																				
2 PLC	±	-																				
3 PLC	±	.010																				
4 PLC	±	-																				
ANGLES	±	-																				
MATERIAL SEE CALLOUTS		FINISH	SEE CALLOUTS	RESTRICTED TO																		
WEIGHT		SIZE	CAGE CODE	DRAWING NO																		
CUSTOMER DRAWING		A1	00779	213289																		
SCALE		2:1	SHEET	1 of 1																		
REV		L1																				