

8CH Darlingtion Sink Driver

IK62083/4

The IK62083~IK62084 are high-voltage, high-current darlington drivers comprised of eight NPN darlington pairs.

All units feature integral clamp diodes for switching inductive loads.

Applications include relay, hammer, lamp and display (LED) drivers.

Features

- Output current (single output) 500mA (Max)
- Output clamp diodes
- Inputs compatible with various types of logic

TYPE	INPUT BASE RESISTOR	DESIGNATION
IK62083N/DW	2.7kΩ	TTL, 5V CMOS
IK62084N/DW	10.5kΩ	6~15V PMOS, CMOS

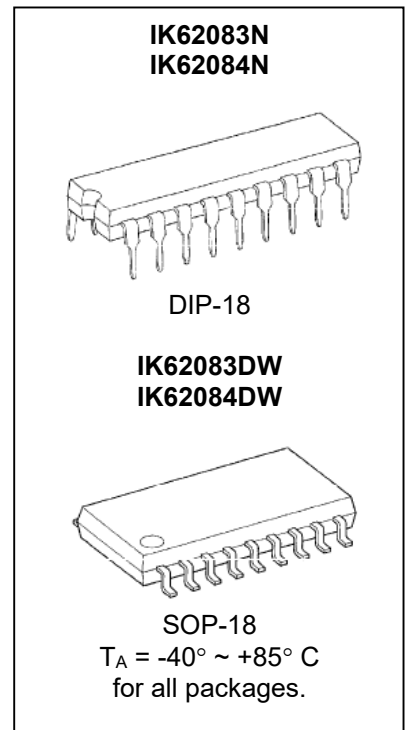

Pin Configuration (top view)

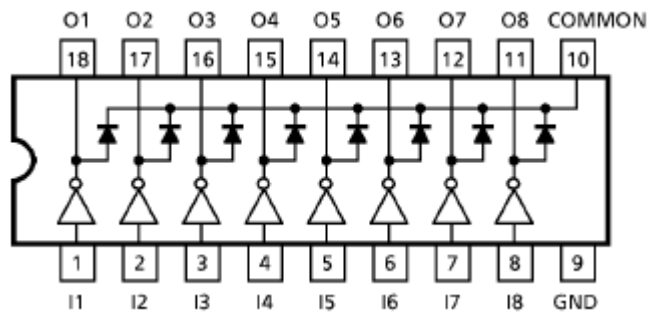

Block Schematics

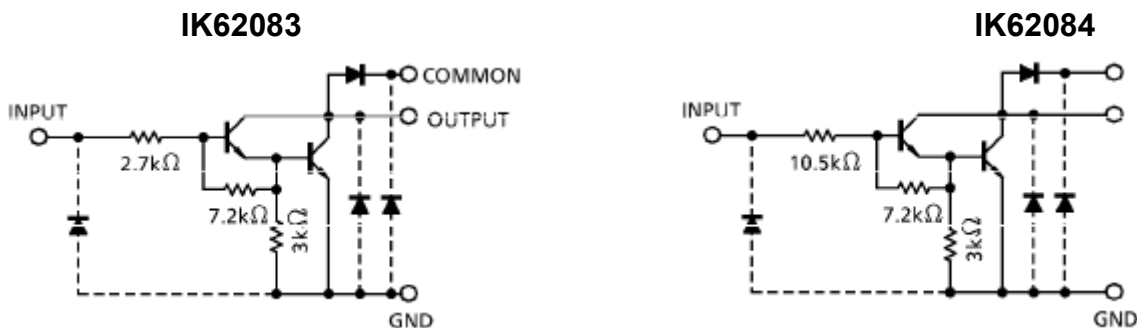

Note: The input and output parasitic diodes cannot be used as clamp diodes.

Absolute Maximum Ratings

T_a =25°C

Parameter	Symbol	Limit Values		Unit
		min.	max.	
Output Sustaining Voltage	V _{CE(SUS)}	-0.5	50	V
Output Current	I _{OUT}	500		mA/ch
Input Voltage	V _{IN}	-0.5	30	V
Clamp Diode Reverse Voltage	V _R	50		V
Clamp Diode Forward Current	I _F	500		mA
Power Dissipation	IK62083N	P _D	1.47	W
	IK62083DW		0.96	
Operating Temperature	T _{opr}	-40	85	°C
Storage Temperature	T _{stg}	-55	150	°C

* Stresses beyond those listed under “absolute maximum ratings” may cause permanent damage to the device. These are stress ratings only and functional operation of the device at these or any other conditions beyond those indicated under “recommended operating conditions” is not implied. Exposure to absolute-maximum-rated conditions for extended periods may affect device reliability.

Recommended Operating Conditions

(T_a=-40~85°C)

Parameter	Symbol	Test Condition	Limit Value			Unit	
			Min	Typ	Max		
Output Sustaining Voltage	V _{CE(SUS)}		0	-	50	V	
Output Current	N	I _{OUT}	T _{pw} =25ms,Duty=10%, 8 Circuits	0	-	347	mA/ch
			T _{pw} =25ms,Duty=50%, 8 Circuits	0	-	123	
	DW	T _{pw} =25ms,Duty=10%, 8 Circuits	0	-	268		
		T _{pw} =25ms,Duty=50%, 8 Circuits	0	-	90		
Input Voltage	V _{IN}		0	-	30	V	
Input Voltage (Output On)	IK62083N/DW	V _{IN(ON)}		3.5	-	30	V
	IK62084N/DW			8	-	30	
Clamp Diode Reverse Voltage	V _R		-	-	50	V	
Clamp Diode Forward Current	I _F		-	-	400	mA	

Electrical Characteristics

Ta = 25°C

Parameter		Symbol	Test Circuit	Test Condition	Limit Values			Unit
					Min	Typ	Max	
Output Leakage Current	IK62083	I _{CEX}	1	V _{CE} =50V, Ta=25°C	-	-	50	uA
				V _{CE} =50V, Ta=85°C	-	-	100	
	IK62084			V _{CE} =50V, V _{IN} =1V	-	-	500	
Collector-Emitter Saturation Voltage		V _{CE(sat)}	2	I _{OUT} =350mA, I _{IN} =500uA	-	1.3	1.6	V
				I _{OUT} =200mA, I _{IN} =350uA	-	1.1	1.3	
				I _{OUT} =100mA, I _{IN} =250uA	-	0.9	1.1	
Input Current	IK62083	I _{IN(ON)}	2	V _{IN} =3.85V	-	0.93	1.35	mA
	IK62084			V _{IN} =5V	-	0.35	0.5	
				V _{IN} =12V	-	1.0	1.45	
Input Voltage (Output On)	IK62083	V _{IN(ON)}	5	V _{CE} =2V, I _{OUT} =200mA	-	-	2.4	V
				V _{CE} =2V, I _{OUT} =250mA	-	-	2.7	
				V _{CE} =2V, I _{OUT} =300mA	-	-	3.0	
	IK62084			V _{CE} =2V, I _{OUT} =125mA	-	-	5.0	
				V _{CE} =2V, I _{OUT} =200mA	-	-	6.0	
				V _{CE} =2V, I _{OUT} =275mA	-	-	7.0	
				V _{CE} =2V, I _{OUT} =350mA	-	-	8.0	
DC Current Transfer Ratio		h _{FE}	2	V _{CE} =2V, I _{OUT} =350mA	1000	-	-	
Clamp Diode Reverse Current		I _R	6	Ta=25°C (Note)	-	-	50	uA
				Ta=85°C (Note)	-	-	100	
Clamp Diode Forward Voltage		V _F	7	I _F =350mA	-	-	2.0	V
Input Capacitance		C _{IN}	-		-	-	15	pF
Turn-On Delay		t _{ON}	8	R _L =125Ω, V _{OUT} =50V	-	0.1	-	us
Turn-Off Delay		t _{OFF}	8	R _L =125Ω, V _{OUT} =50V	-	0.21	-	us

Note : V_R=V_RMAX

Test Circuit

1. I_{CEX}

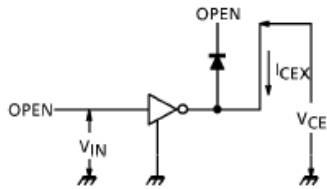

2. $V_{CE(sat)}$, h_{FE}

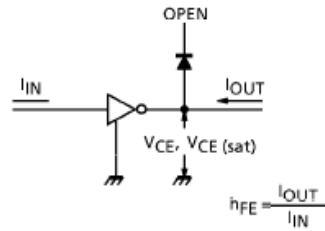

3. $I_{IN(ON)}$

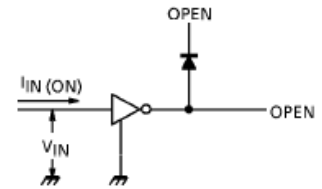

4. $I_{IN(OFF)}$

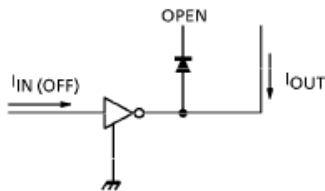

5. $V_{IN(ON)}$

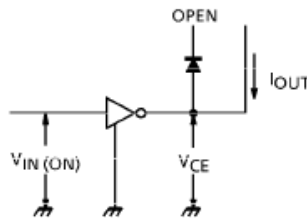

6. I_R

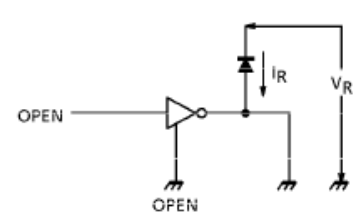

7. V_F

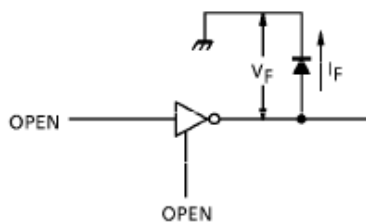

8. t_{ON} , t_{OFF}

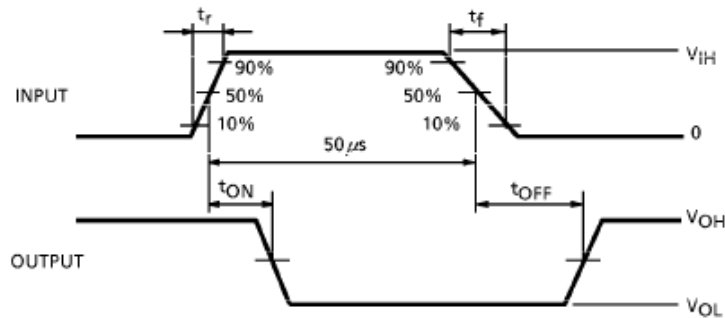
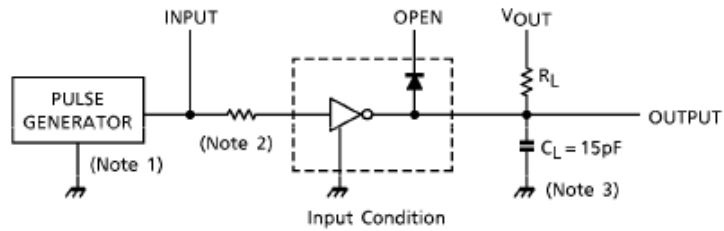

Note 1 : Pulse Width 50us, Duty Cycle 10%
Output Impedance 50Ω, $t_r \leq 5ns$, $t_f \leq 10ns$

Note 2 : See below.

Input Condition

Type number	R1	V _{IH}
IK62083	0Ω	3V
IK62084	0Ω	8V

Note 3 : C_L includes probe and jig capacitance

Precautions for Using

Utmost care is necessary in the design of output line, COMMON and GND line since IC may be destroyed due to short-circuit between outputs, air contaminaton fault, or fault by improper grounding.

IK62083N

IIN vs VIN

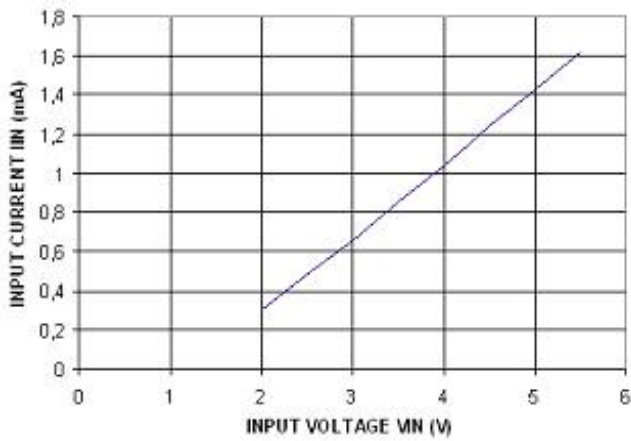

IK62084

IIN vs VIN

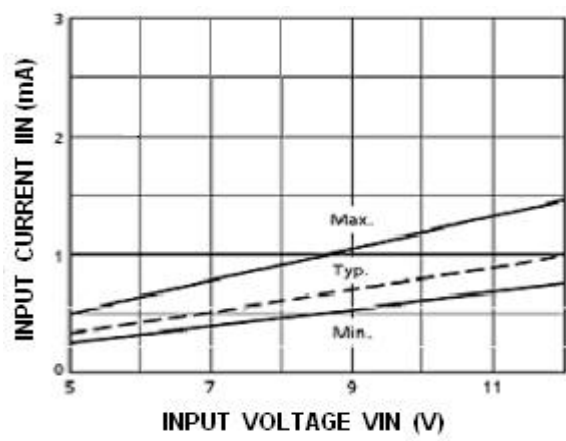

IOUT vs DUTY CYCLE

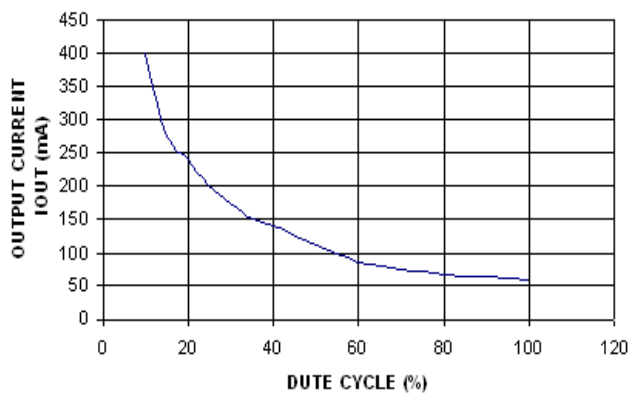

IOUT vs VCE (sat)

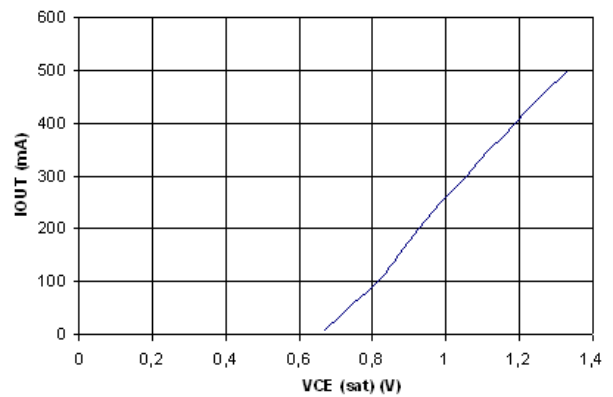

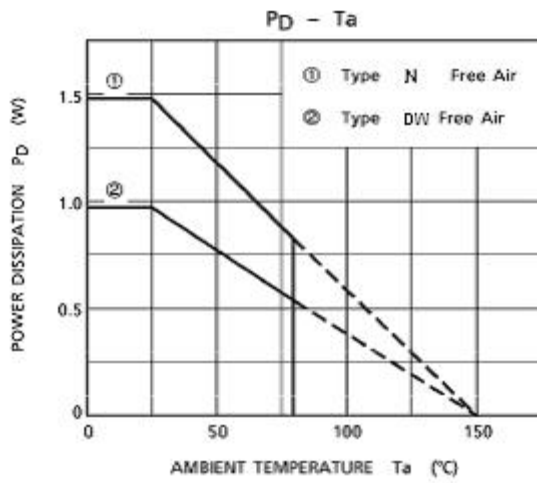
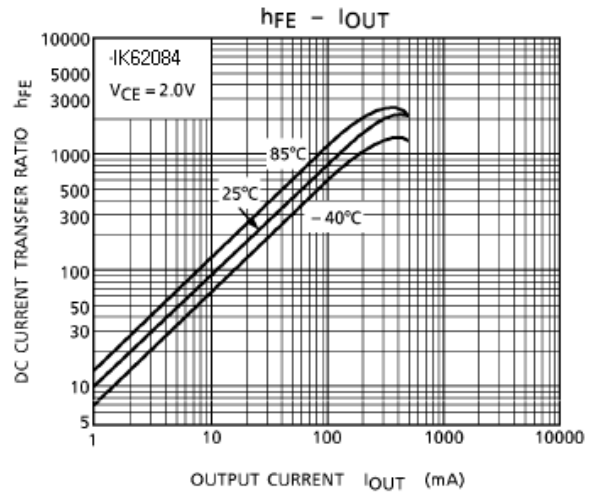
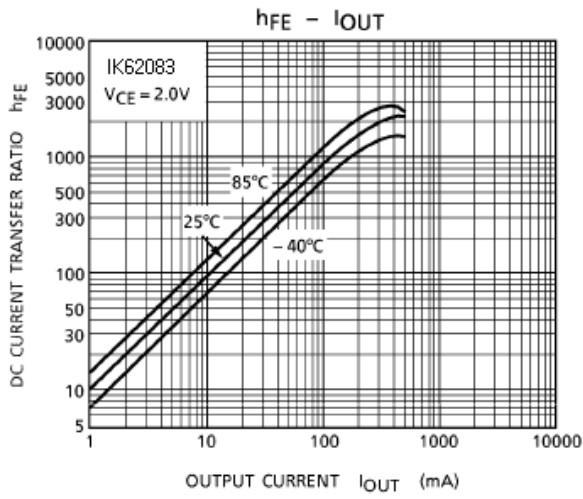

Package Dimensions

DIP-18

Unit: mm

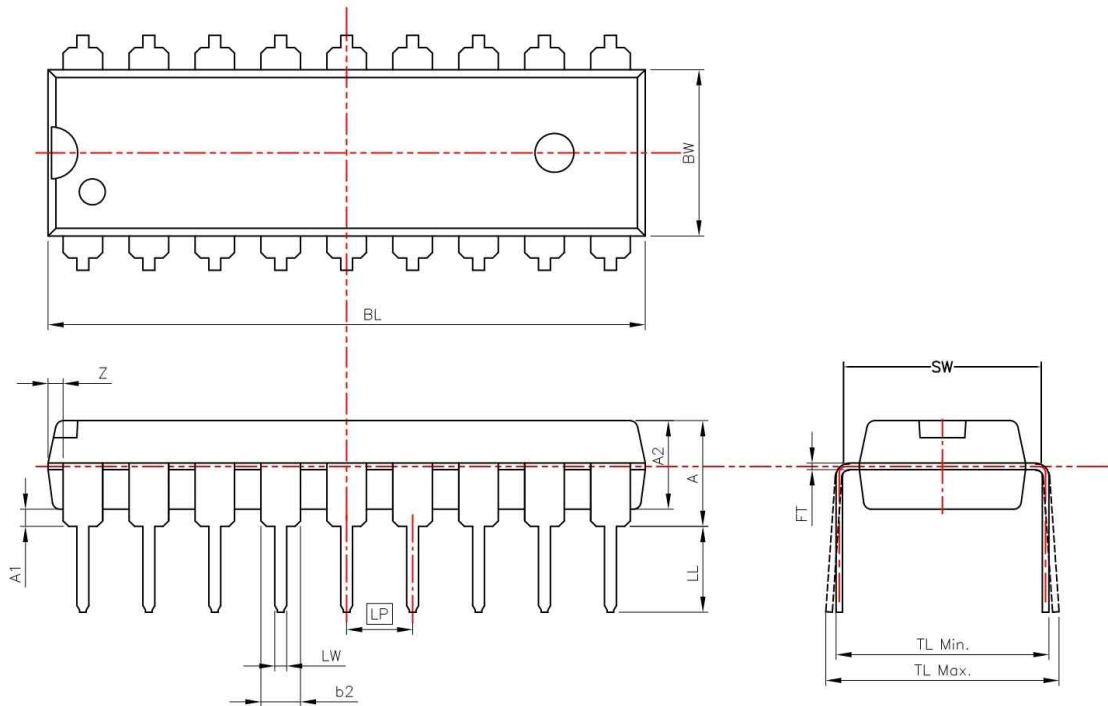

SYMBOL	Dimension (mm)		
	Min	Typ	Max
BL	22.800		23.200
BW	6.200		6.600
FT	0.246		0.262
TL	7.900		8.800
LP	2.515		2.565
LW	0.432		0.482
A			4.310
A1	0.550		0.750
A2	3.300		3.500
b2		1.524	
LL	3.200		3.500
SW		7.620	
Z		0.570	

SOP-18

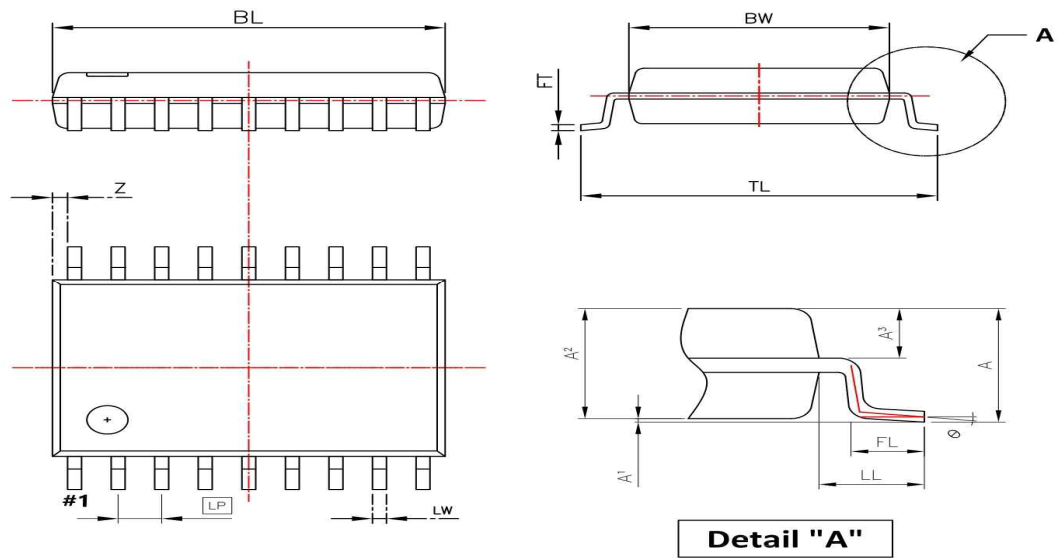

SYMBOL	Dimension (mm)		
	Min	Typ	Max
BL	11.250		11.650
BW	7.400		7.800
FT	0.204		0.304
TL	10.300		10.500
LP	1.245		1.295
LW	0.381		0.431
A			2.700
A1	0.050		0.250
A2	2.250		2.450
A3	1.048BSC		
LL	1.40BSC		
FL	0.670		1.070
Ø	0		8
Z		0.440	