

APPROVED: \_\_\_\_\_  
 DATE: \_\_\_\_\_ TITLE: \_\_\_\_\_

| Rev | AWO # | Description    | Date    | Appr  |
|-----|-------|----------------|---------|-------|
| -   |       | RELEASED       | 4/11/17 |       |
| A   |       | UPDATE DRAWING | 5/29/20 | LH/RC |

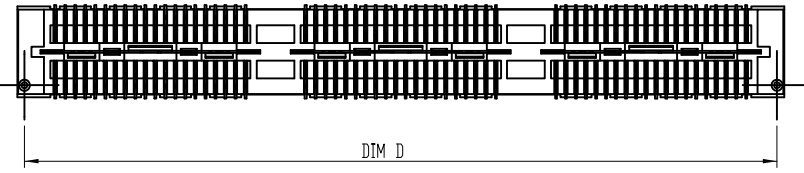
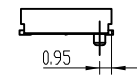
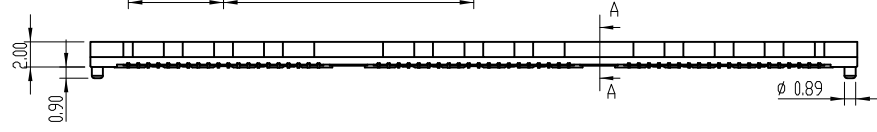
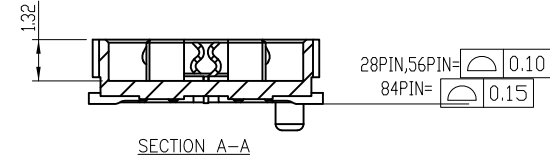
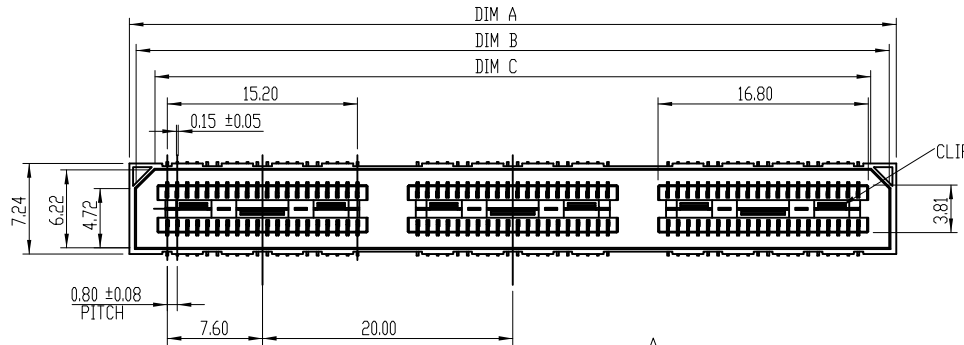

|       | 40 PIN | 80 PIN | 120 PIN |
|-------|--------|--------|---------|
| DIM A | 21.27  | 41.27  | 61.27   |
| DIM B | 20.17  | 40.17  | 60.17   |
| DIM C | 17.17  | 37.17  | 57.17   |
| DIM D | 20.13  | 40.13  | 60.13   |

Mated with: BB8H-PC-XXX-G-4.27-HF-T/R

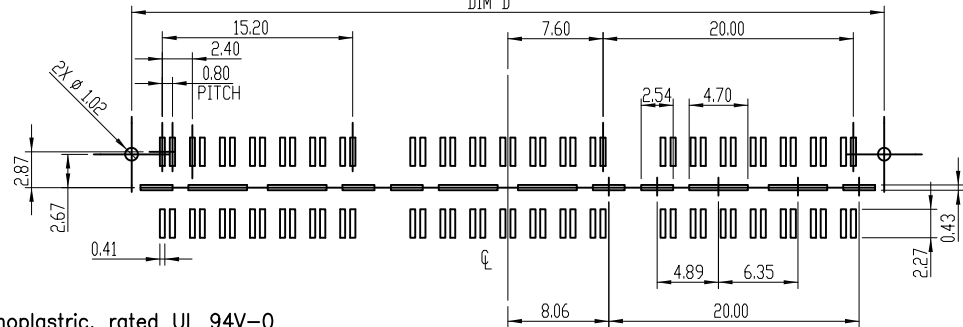

RECOMMENDED P.C.B LAYOUT

SPECIFICATIONS:

Material:  
 Insulator: Hi-Temp thermoplastic, rated UL 94V-0  
 Insulator color: Black  
 Contacts: Copper Alloy  
 Plating:  
 8u" Gold over Nickel underplate on contact area  
 1u" Gold over Nickel underplate on solder tails  
 Electrical:  
 Current Rating: Contact: 2.0A  
 Ground Plane: 7.8A  
 Voltage Rating: 225VAC (5mm Stack Height)  
 Dielectric withstanding voltage: 675 VAC  
 Mating cycles: 100 insertions  
 Temperature Rating:  
 Temperature: -55°C to +125°C  
 Environmental:  
 Lead free, RoHS compliant



PACKAGED ON TAPE & REEL

UNLESS OTHERWISE SPECIFIED  
 ALL DIMENSIONS ARE MILLIMETERS  
 TOLERANCES: EXCEPT AS NOTED

|     | MM    | ANG  |
|-----|-------|------|
| X.  | ± .30 | ± 2' |
| .X  | ± .15 |      |
| .XX | + .12 |      |

| APPROVALS |    | DATE    |
|-----------|----|---------|
| DRAWN     | AY | 4/14/17 |
| CHECKED   | OC | 4/14/17 |
| APPROVED  |    |         |

**ADAM TECH INTERCONNECTS** 909 Rahway Avenue, Union, NJ 07083  
 Phone: 908-687-5000 Fax: 908-687-5710

TITLE: HIGH SPEED BOARD-TO-BOARD SOCKET w/  
 GROUND PLANE, 0.031" [0.80mm], SMT TYPE

| SIZE | PART NO.                  | REV. |
|------|---------------------------|------|
| X    | BB8H-SC-XXX-G-2.05-HF-T/R | A    |

REF: S00013T SCALE: NTS SHEET 1 OF 3

6

5

4

3

2

1

APPROVED: \_\_\_\_\_

DATE: \_\_\_\_\_ TITLE: \_\_\_\_\_

|     |       |             |      |      |
|-----|-------|-------------|------|------|
| Rev | AWO # | Description | Date | Appr |
|-----|-------|-------------|------|------|

SEE SHT 1 OF 3 FOR REVISION

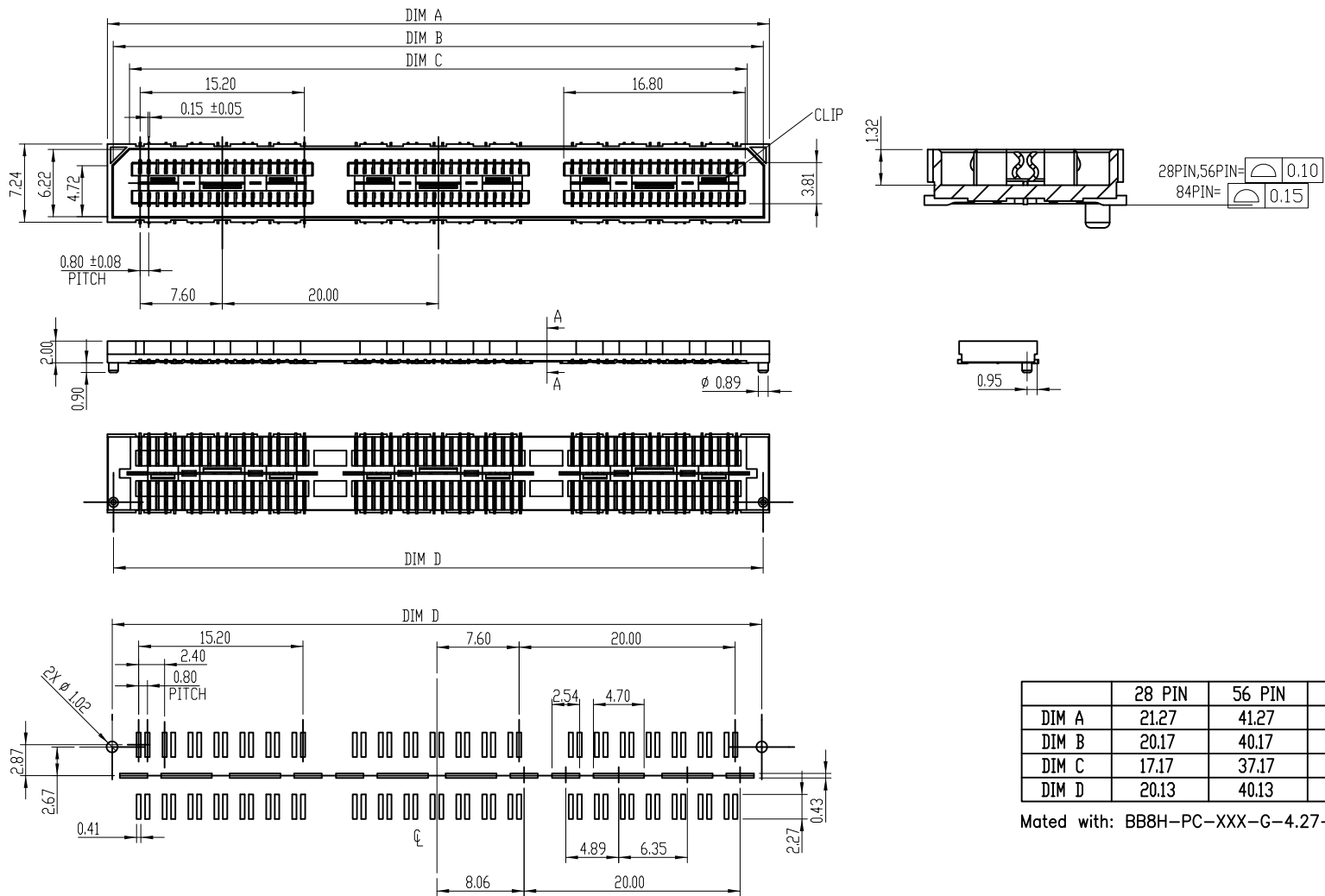

UNLESS OTHERWISE SPECIFIED  
 ALL DIMENSIONS ARE MILLIMETERS  
 TOLERANCES: EXCEPT AS NOTED

|           |      |
|-----------|------|
| MM        | ANG  |
| .X ± .30  | ± 2' |
| .X ± .15  |      |
| .XX + .12 |      |

**ADAM TECH**  
 INTERCONNECTS

909 Rahway Avenue,  
 Union, NJ 07083  
 Phone: 908-687-5000  
 Fax: 908-687-5710

|           |    |         |
|-----------|----|---------|
| APPROVALS |    | DATE    |
| DRAWN     | AY | 4/14/17 |
| CHECKED   | OC | 4/14/17 |
| APPROVED  |    |         |

TITLE: HIGH SPEED BOARD-TO-BOARD SOCKET w/  
 GROUND PLANE, 0.031" [0.80mm], SMT TYPE

|              |                           |              |
|--------------|---------------------------|--------------|
| SIZE         | PART NO.                  | REV.         |
| X            | BB8H-SC-XXX-G-2.05-HF-T/R | A            |
| REF: S00013T | SCALE: NTS                | SHEET 2 OF 3 |

6

5

4

3

2

1

D

D

C

C

B

B

A

A

6

5

4

3

2

1

APPROVED: \_\_\_\_\_

DATE: \_\_\_\_\_ TITLE: \_\_\_\_\_

|     |       |             |      |      |
|-----|-------|-------------|------|------|
| Rev | AWO # | Description | Date | Appr |
|-----|-------|-------------|------|------|

SEE SHT 1 OF 3 FOR REVISION

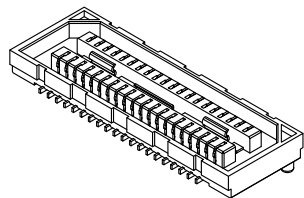

40 PIN

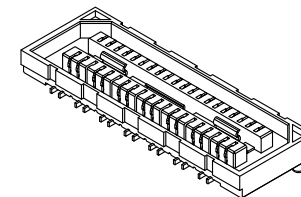

28 PIN

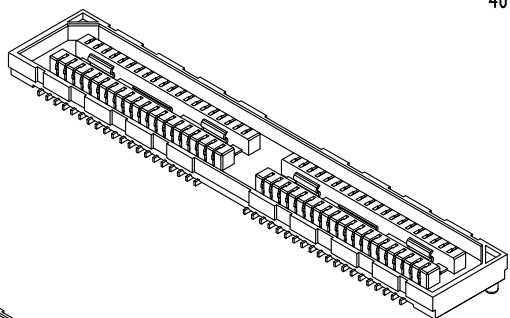

80 PIN

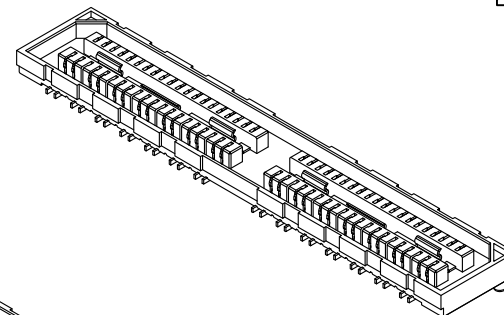

56 PIN

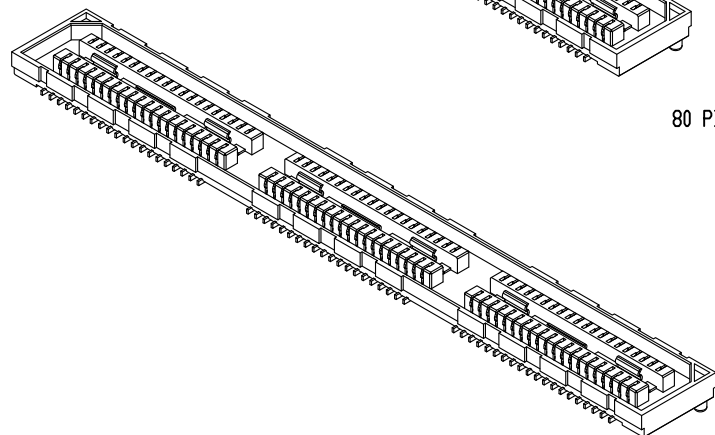

120 PIN

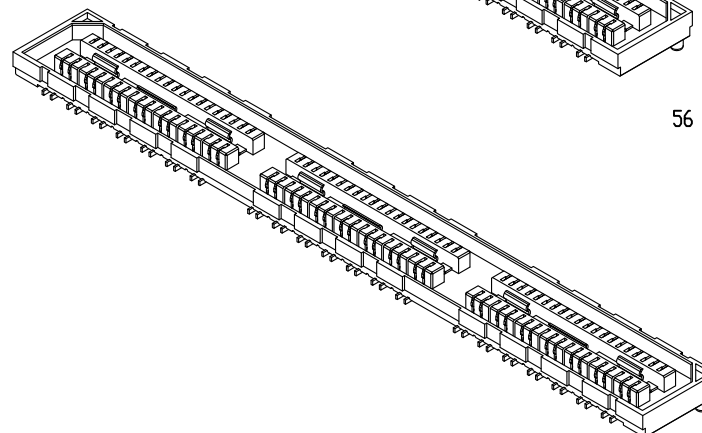

84 PIN

UNLESS OTHERWISE SPECIFIED  
 ALL DIMENSIONS ARE MILLIMETERS  
 TOLERANCES: EXCEPT AS NOTED

|           |      |
|-----------|------|
| MM        | ANG  |
| X. ± .30  | ± 2' |
| .X ± .15  |      |
| .XX + .12 |      |

**ADAM**  
**TECH**  
 INTERCONNECTS

909 Rahway Avenue,  
 Union, NJ 07083  
 Phone: 908-687-5000  
 Fax: 908-687-5710

|           |    |         |
|-----------|----|---------|
| APPROVALS |    | DATE    |
| DRAWN     | AY | 4/14/17 |
| CHECKED   | OC | 4/14/17 |
| APPROVED  |    |         |

TITLE HIGH SPEED BOARD-TO-BOARD SOCKET w/  
 GROUND PLANE, 0.031" [0.80mm], SMT TYPE

|              |                                       |              |
|--------------|---------------------------------------|--------------|
| SIZE<br>X    | PART NO.<br>BB8H-SC-XXX-G-2.05-HF-T/R | REV.<br>A    |
| REF: S00013T | SCALE: NTS                            | SHEET 3 OF 3 |

6

5

4

3

2

1

D

D

C

C

B

B

A

A