

BM29 Series

Ultra-Small, Power/Signal Contact Design for Board-to-Board/ FPC-to-Board Providing 3A Max. Current

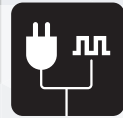

Ultra Miniature



Power / Signal



Robust

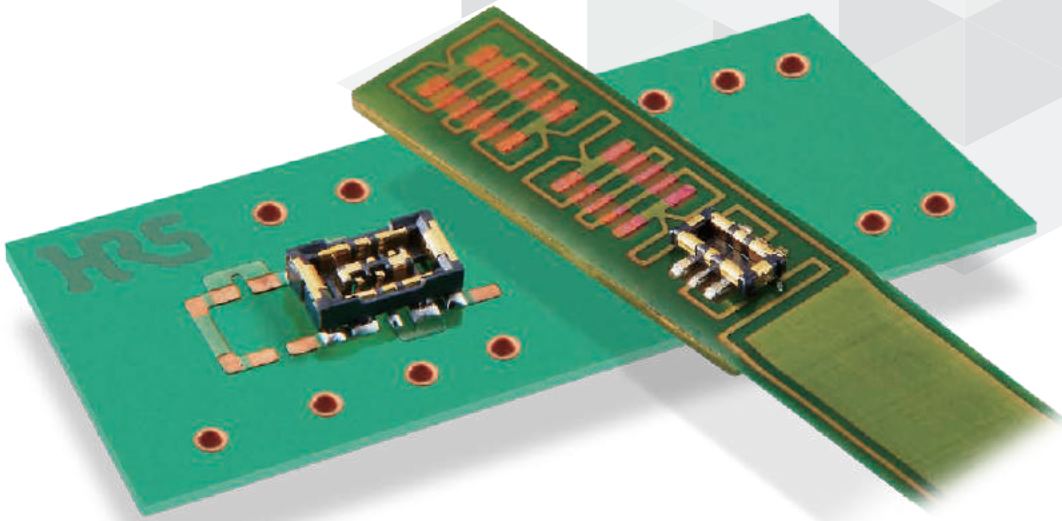

Features

1. Space-Saving Design

Compact and flexible design ideal for mobile devices.

Pitch : 0.35mm, Depth : 1.5mm,

Stacking Height : 0.6mm

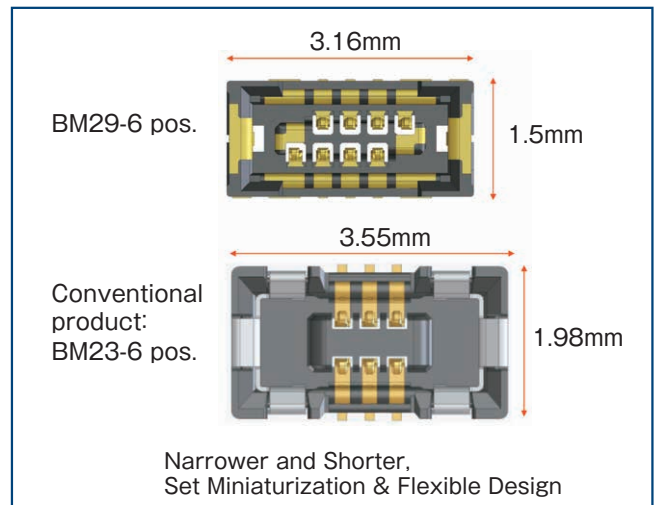

20% reduction in size compared to HRS's conventional products.

2. Equipped with Power Contacts Capable of Handling up to 3A Current.

Rated current : 3A (Power Contact),
0.3A (Signal Contact)

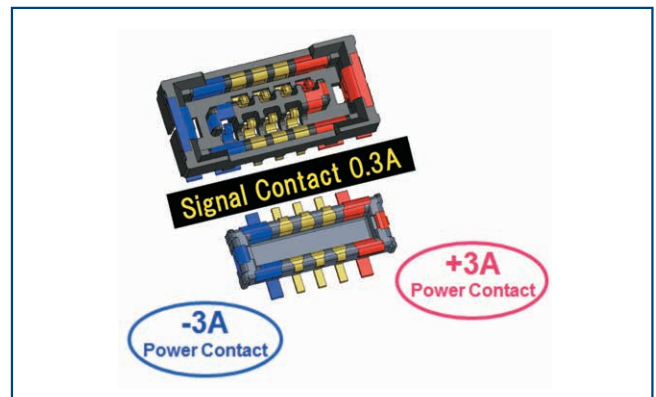

Combination Power / Signal Contact Design

3. The proprietary metal guide prevents the connector from being damaged against offset mating.

Even when mated in a misaligned state, metal-to-metal contact reduces the risk of damage to the connector.

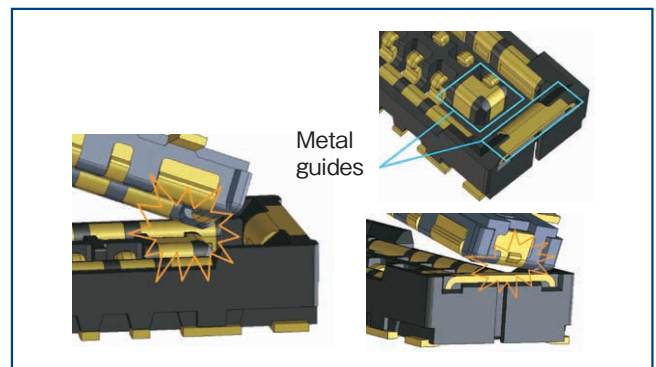

4. A tactile click ensures secure mating.

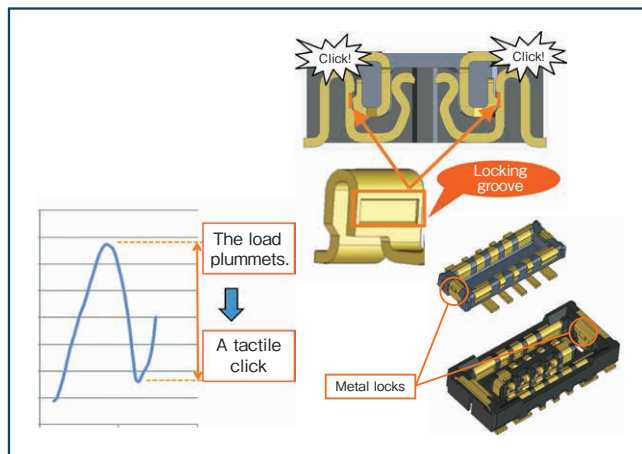

The contact is designed to provide a tactile click.

5. High Contact Reliability with 2-Points Contact

Product Specifications

Rated Current	2, 4, 6pos.	12, 24pos.	Operating Temperature (Note 1)	-40 to +85°C
	Power Contact : 3A Signal Contact : 0.3A	Power Contact : 2A Signal Contact : 0.3A	Storage Temperature (Note 2)	-10 to +60°C
Rated Voltage	30V AC/DC			

Operating Humidity Range (Note 3)	90% RH Max.	Storage Humidity Range (Note 2, 3)	90% RH Max.
-----------------------------------	-------------	------------------------------------	-------------

Item	Standards	Condition
Insulation Resistance	1,000M Ω Min.	Measured at 100V DC
Withstanding Voltage	No flashover or dielectric breakdown	150V AC for 1 min.
Contact Resistance	Signal Contact: 100m Ω Power Contact: 30m Ω	Measured at 20mV AC, 1kHz, 1mA
Vibration Resistance	No electrical discontinuity of 1 μ s or more	Frequency 10 to 55Hz, Half amplitude 0.75mm, 1 cycle for 5 min., 3 axial, 10 cycles
Humidity Resistance	Contact Resistance Signal Contact: 100m Ω , Power Contact: 30m Ω Insulation Resistance: 100M Ω Min.	Temperature 40 \pm 2 °C , Humidity 90 to 95%, Left for 96 hours
Temperature Cycle	Contact Resistance Signal Contact: 100m Ω , Power Contact: 30m Ω Insulation Resistance: 100M Ω Min.	(-55°C : 30 min. -- > 5 to 35°C : 10 min. -- > 85°C : 30 min. -- > 5 to 35°C : 10 min.) 5 cycles
Mating Durability	Contact Resistance: 100m Ω Max.	10 times
Solder Heat Resistance	No dissolution or resin melting that will affect performance.	Reflow: In recommended Temperature Profile, Hand Solder: Soldering Iron Temperature 350°C within 3 seconds

Note 1 : Includes temperature rise caused by current flow.

Note 2 : Storage refers to the long-term storage condition for unused products before the board mounting.

Operating temperature and humidity range apply when the product is not powered after PCB mounting and when temporarily stored during transportation.

Note 3 : Use without condensation.

Materials / Finish

Item	Component	Material	Finish/Color	Remarks
Receptacle Plug	Insulator	LCP	Black	UL94V-0
	Signal Contact	Phosphorous Bronze	Gold Plating	-
	Power Contact	Phosphorous Bronze	Gold Plating	-

Product Number Structure

Refer to the chart below when determining the product specifications from the product number.
Please select from the product numbers listed in this catalog when placing orders.

■ Receptacle

BM29B 0.6 - # DS/ 2 - 0.35 V (##)

① ② ③ ④ ⑤ ⑥ ⑦ ⑧

① Series Name	BM29B	⑤ No. of Pos. (Power Contact)	2 pos.
② Stacking Height		⑥ Contact Pitch	0.35mm
③ No. of Pos. (Signal Contact)	2, 4, 6, 12 and 24 pos.	⑦ Terminal Design V	Straight SMT
④ Connector Type	DS: Receptacle	⑧ Specifications of Gold Plating and Packaging	Packaging (51): Embossed Tape Packaging (20,000 pcs per reel) (53): Embossed Tape Packaging (1,000 pcs per reel)

■ Plug

BM29B - # DP 2 - 0.35 V (##)

① ② ③ ④ ⑤ ⑥ ⑦

① Series Name	BM29B	⑤ Contact Pitch	0.35mm
② No. of Pos. (Signal Contact)	2 pos.	⑥ Terminal Design V	Straight SMT
③ Connector Type	DP: Plug	⑦ Specifications of Gold Plating and Packaging	Packaging (51): Embossed Tape Packaging (20,000 pcs per reel) (53): Embossed Tape Packaging (1,000 pcs per reel)
④ No. of Pos. (Power Contact)	2, 4, 6, 12 and 24 pos.		

Receptacle

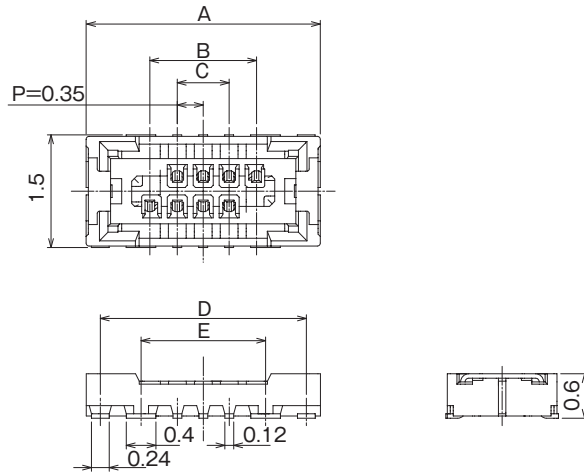

Recommended metal mask thickness : 80 μ m, Aperture ratio : 100%

Unit : mm

Part No.	HRS No.	No. of Pos.		A	B	C	D	E	Purchase Unit (#): (51)	Purchase Unit (#): (53)
		Signal	Power							
BM29B0.6-2DS/2-0.35V(##)	CL0673-7001-0-##	2	2	2.46	0.7	—	2.08	0.98	20,000pcs per reel	1,000pcs per reel
BM29B0.6-4DS/2-0.35V(##)	CL0673-7063-0-##	4	2	2.81	1.09	0.35	2.43	1.33		
BM29B0.6-6DS/2-0.35V(##)	CL0673-7003-0-##	6	2	3.16	1.44	0.7	2.78	1.68		
BM29B0.6-12DS/2-0.35V(##)	CL0673-7080-0-##	12	2	4.21	2.49	1.75	3.83	2.73		
BM29B0.6-24DS/2-0.35V(##)	CL0673-7053-0-##	24	2	6.31	4.59	3.85	5.93	4.83		

Note : This connector has no polarity.

Recommended PCB Pattern

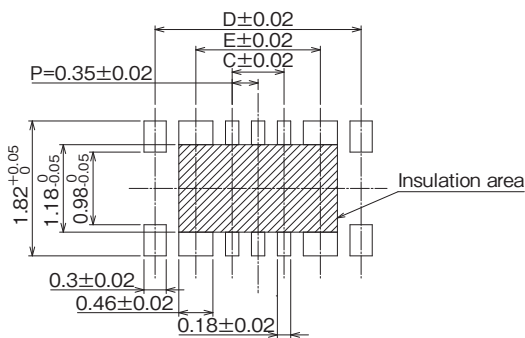

Plug

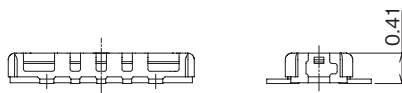
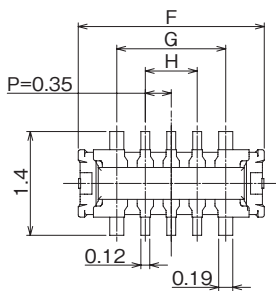

Recommended metal mask thickness : 80 μ m, Aperture ratio : 80%

Unit : mm

Part No.	HRS No.	No. of Pos.		F	G	H	Purchase Unit (#):(51)	Purchase Unit (#):(53)
		Signal	Power					
BM29B-2DP/2-0.35V(##)	CL0673-7002-0-##	2	2	1.81	0.77	—	20,000pcs per reel	1,000pcs per reel
BM29B-4DP/2-0.35V(##)	CL0673-7064-0-##	4	2	2.16	1.12	0.35		
BM29B-6DP/2-0.35V(##)	CL0673-7004-0-##	6	2	2.51	1.47	0.7		
BM29B-12DP/2-0.35V(##)	CL0673-7081-0-##	12	2	3.56	2.52	1.75		
BM29B-24DP/2-0.35V(##)	CL0673-7052-0-##	24	2	5.66	4.62	3.85		

Note : This connector has no polarity.

Recommended PCB Pattern

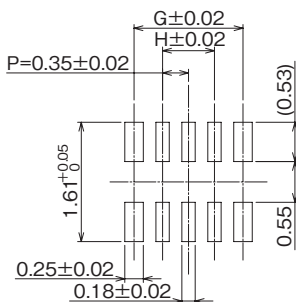

Packaging Specifications Diagram (JIS C 0806 Compliant)

Receptacle

● Embossed Carrier Tape Dimensions

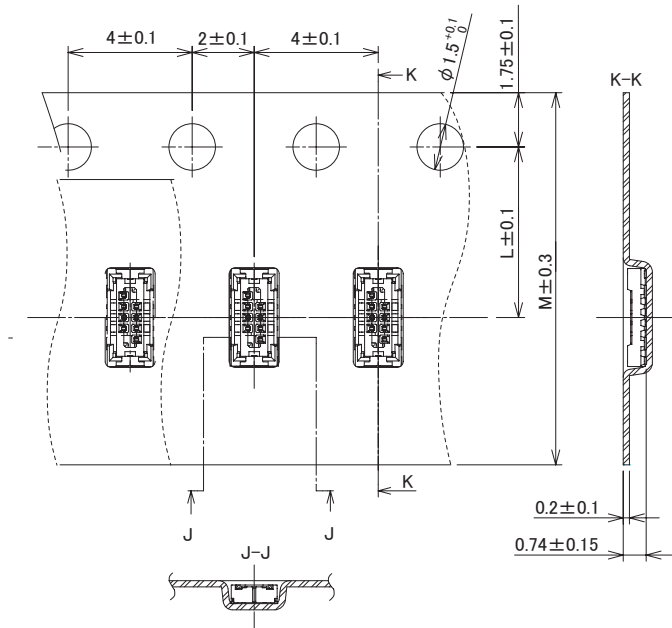

● Reel Dimensions

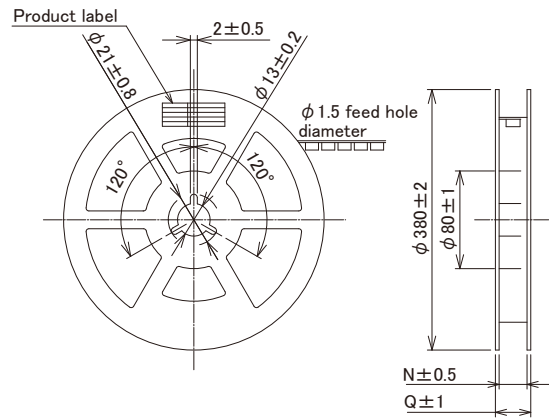

Unit : mm

Part No.	HRS No.	No. of Pos.		L	M	N	Q	Purchase Unit (#):(51)	Purchase Unit (#):(53)
		Signal	Power						
BM29B0.6-2DS/2-0.35V(##)	CL0673-7001-0-##	2	2	5.5	12	13.5	17.5	20,000pcs per reel	1,000pcs per reel
BM29B0.6-4DS/2-0.35V(##)	CL0673-7063-0-##	4	2	5.5	12	13.5	17.5		
BM29B0.6-6DS/2-0.35V(##)	CL0673-7003-0-##	6	2	5.5	12	13.5	17.5		
BM29B0.6-12DS/2-0.35V(##)	CL0673-7080-0-##	12	2	7.5	16	17.5	21.5		
BM29B0.6-24DS/2-0.35V(##)	CL0673-7053-0-##	24	2	7.5	16	17.4	21.4		

Plug

● Embossed Carrier Tape Dimensions

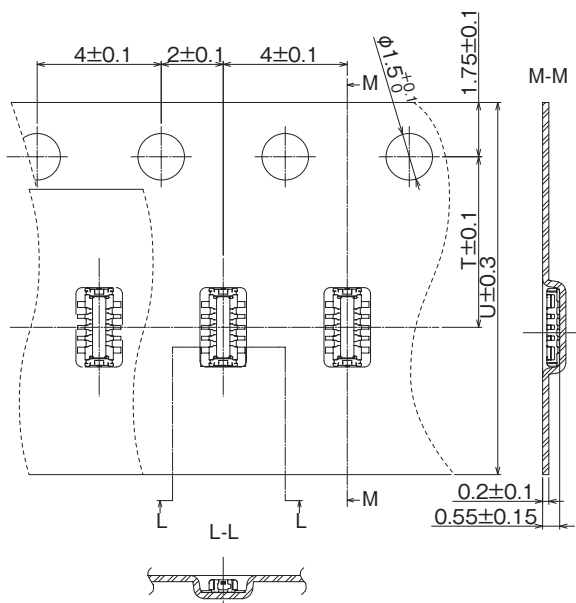

● Reel Dimensions

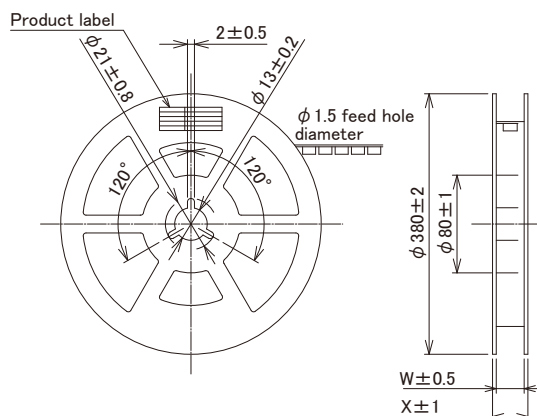

Unit : mm

Part No.	HRS No.	No. of Pos.		T	U	W	X	Purchase Unit (#):(51)	Purchase Unit (#):(53)
		Signal	Power						
BM29B-2DP/2-0.35V(##)	CL0673-7002-0-##	2	2	5.5	12	13.5	17.5	20,000pcs per reel	1,000pcs per reel
BM29B-4DP/2-0.35V(##)	CL0673-7064-0-##	4	2	5.5	12	13.5	17.5		
BM29B-6DP/2-0.35V(##)	CL0673-7004-0-##	6	2	5.5	12	13.5	17.5		
BM29B-12DP/2-0.35V(##)	CL0673-7081-0-##	12	2	5.5	12	13.5	17.5		
BM29B-24DP/2-0.35V(##)	CL0673-7052-0-##	24	2	7.5	16	17.4	21.4		

Precautions

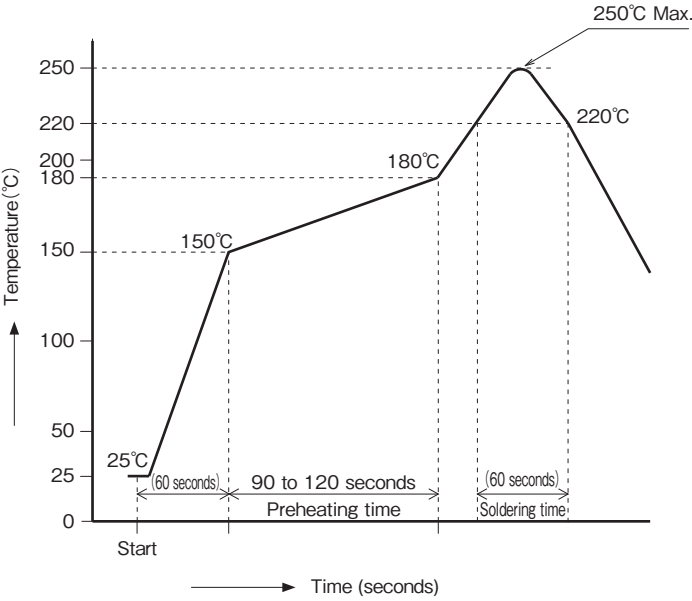
<p>Recommended Temperature Profile</p>	 <p>[Conditions]</p> <ol style="list-style-type: none"> 1. Peak Temperature : 250°C Max. 2. Heating : 220°C Min., within 60sec. 3. Preheating : 150 to 180°C , 90 to 120sec. 4. Number of Reflow Cycles : 2 cycles Max. <p>Note 1: Temperature refers to the surface temperature of the board near the connector lead. Note 2: When using nitrogen reflow, please mount the oxygen concentration at 1000[ppm] or higher. If less than 1000[ppm], please contact us.</p>
<p>Recommended Manual Soldering Conditions</p>	<p>Soldering iron temperature : 340 ± 10°C , Soldering Time : Within 3 sec.</p>
<p>Recommended Metal Mask Thickness and Open Area to PCB Pattern (Area Ratio)</p>	<p>Thickness : 0.08mm, Aperture Ratio : DS 100%, DP 80%</p>
<p>Board Warpage</p>	<p>Max. of 0.02mm at the center in reference to both ends of the connector.</p>
<p>Cleaning</p>	<p>Cleaning is not recommended. If you clean this product, please evaluate its performance before using it. (Cleaning may impair the mating/unmating properties and lower resistance to environmental factors.)</p>
<p>Precautions</p>	<ul style="list-style-type: none"> ■ Be careful when mating/unmating the connector when it is not mounted on the PCB as it may cause damage/deformation to contacts. ■ Avoid supporting the PCB only with the connectors. Support it by other means such as bolts, screws, posts, etc. ■ Excessive wrenching during unmating/mating may result in damage. ■ In the case of hand soldering, please do not apply any flux which could cause flux wicking. ■ This product may have slight color differences due to production lot variability, but this does not affect the performance. ■ Please refer to the following page for handling precautions when inserting and removing. ■ Because the product can disengage if dropped (or other impact), or by FPC routing, it is advised to secure the mated connectors to the board with housings and cushioning materials.

Handling Precautions for Connector Insertion

Be sure to mate this product manually.

Mating Procedure

- 1) Align the connector at the guide.
A guide rib (tapered metal) is provided on the outer wall of the connector for mating support.
Align the connector to this guide rib.

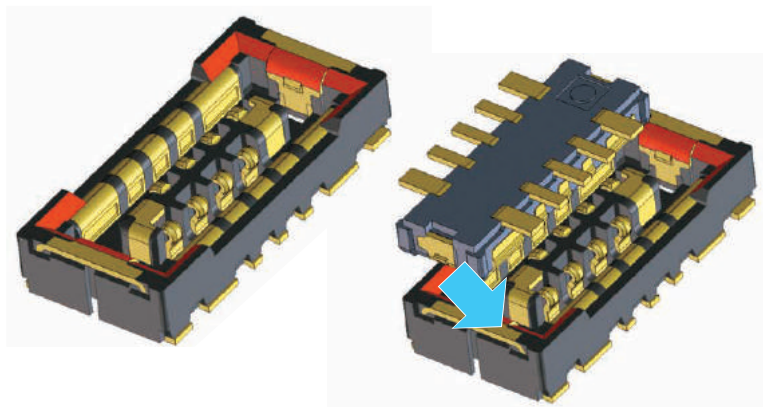

- 2) The connector enters automatically.
The connector slightly lowers when aligned correctly.
Find the guide by moving the connector in the X and Y directions.

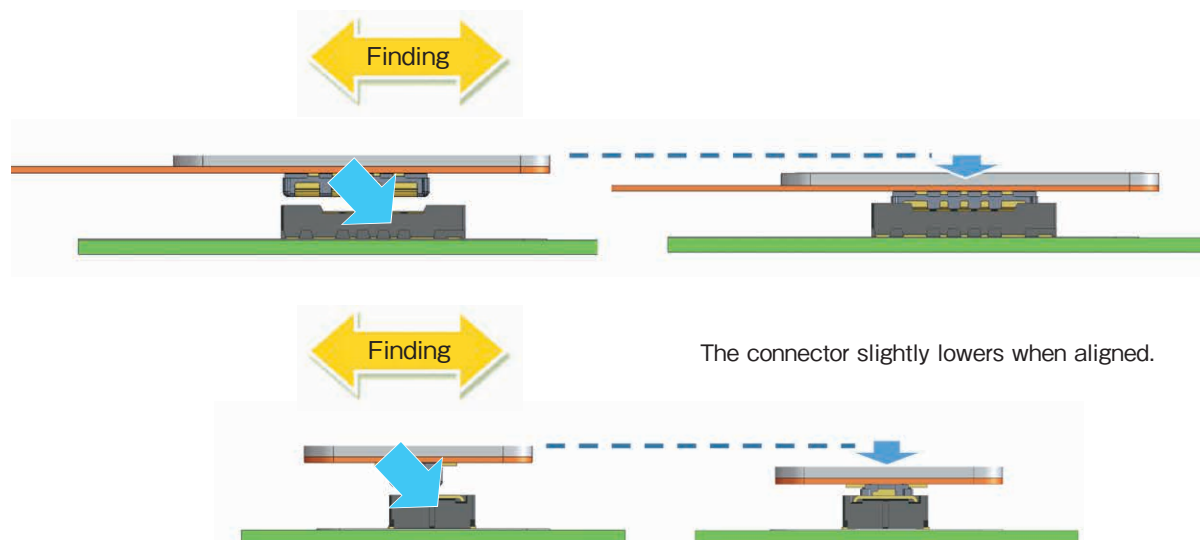

- 3) Once aligned, mate the connector fully.
The connector becomes parallel when aligned. You cannot move it laterally and longitudinally.
- 4) Confirm the mated connector.
If incorrectly mated, remove, and mate it again.

Handling Precautions for Connector Removal

1) Vertical direction

When removing the connector, remove it vertically. Number of contacts, FPC thickness, or other factors may make the vertical removal difficult.

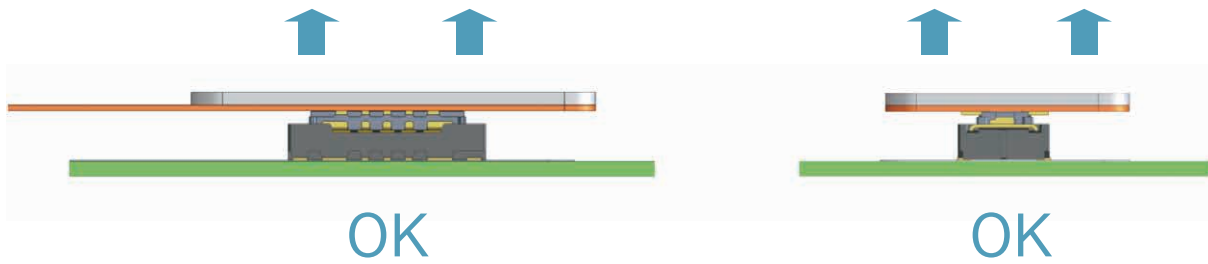

2) Longitudinal removal

Remove the connector in the pitch direction in a slanted manner.

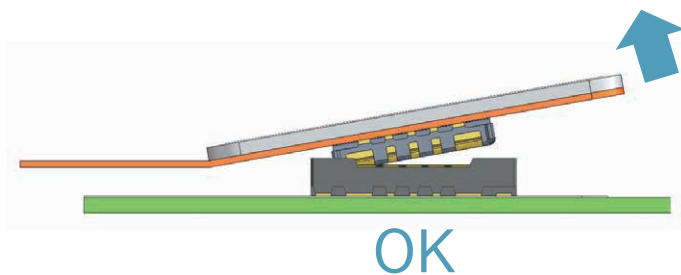

3) Lateral removal

Pull out the tip end of the FPC in the vertical direction. Applying a large force horizontally could deform the contacts.



4) Evaluate the mated state for thin FPCs.

Connector breakage or peeling off at soldering area could occur if the FPC does not have enough rigidity, please check the action in advance on the same type of FPC.

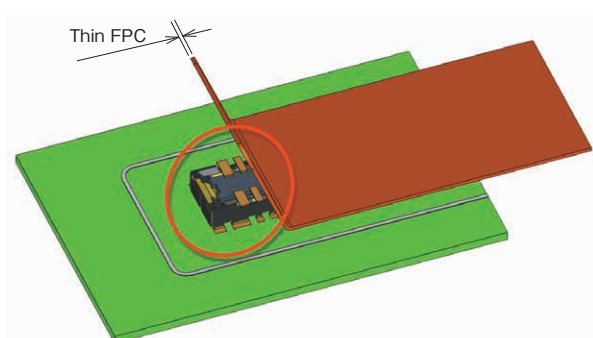

While Taking into Consideration

Specifications mentioned in this catalog are reference values.

When considering to order or use this product, please review the Drawing and Product Specifications sheets.

Use an appropriate cable when using the connector in combination with cables.

If considering usage of a non-specified cable, please contact your sales representative.

If assembly process is done by jigs & tools which are not identified by Hirose, the warranty of the product may be affected.

If considering usage for below mentioned applications, please contact your sales representative.

In cases where the application will demand a high level of reliability, such as automotive, medical instruments, public infrastructure, aerospace/defense etc. Hirose must review before assurance of reliability can be given.

HIROSE**HIROSE ELECTRIC CO.,LTD.**2-6-3 Nakagawa Chuoh, Tsuzuki-Ku, Yokohama-Shi 224-8540, JAPAN
<https://www.hirose.com>