

Type	n	a	c	d
M	19	48.26	73.66	88.9
M/2	3	7.62	33.02	48.26

Mounting holes in PCB

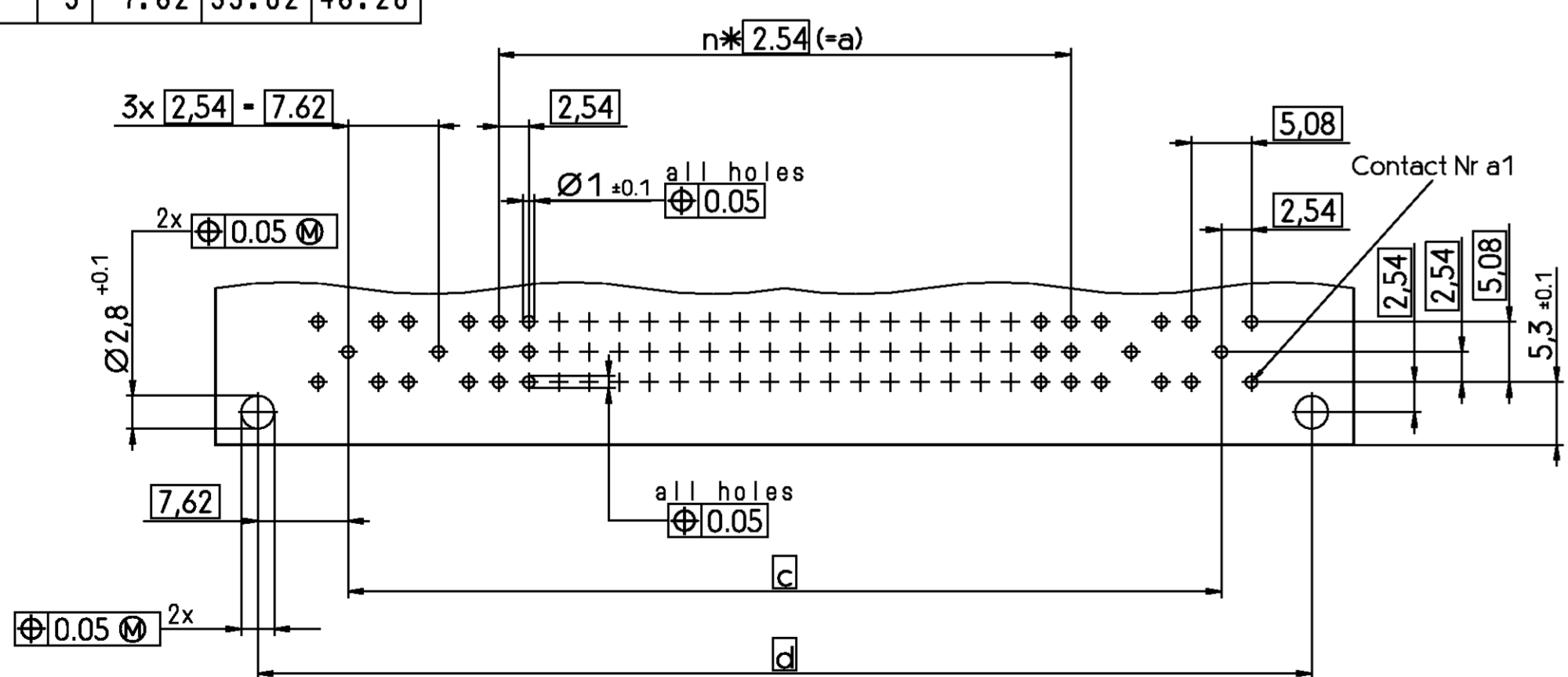

V 4 2 2 5 4 - B 1 \* \* \* - M \* \* \*

Code for performance level

Code for termination style

Style, nr of contacts and contact assignment : see page 2

Termination Style

Soldering/Wire-Wrap pins

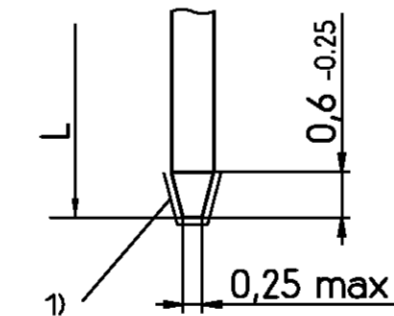

1) Cutting edges not plated  
Terminations Sn plated

Soldering lug

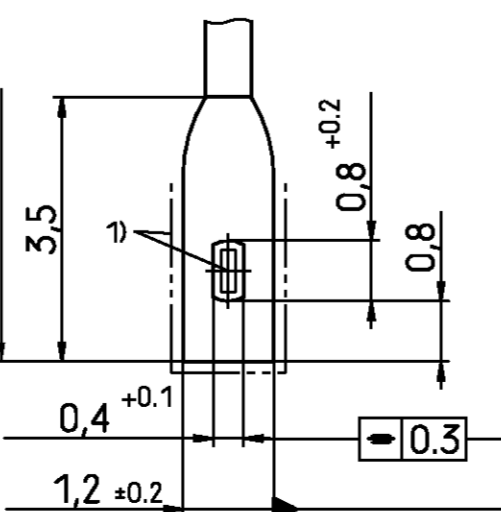

L	Code
3 -0.4	00
2.9 ±0.3	01
4.5 ±0.3	02
13 +0.5	40
11 +0.5	41
17 +0.5	42
5.5 ±0.3	35
10 -0.5	

V42254-B1\*\*\*-M\*\*\*

Contact: Dimensions, plating, material, pre-mating

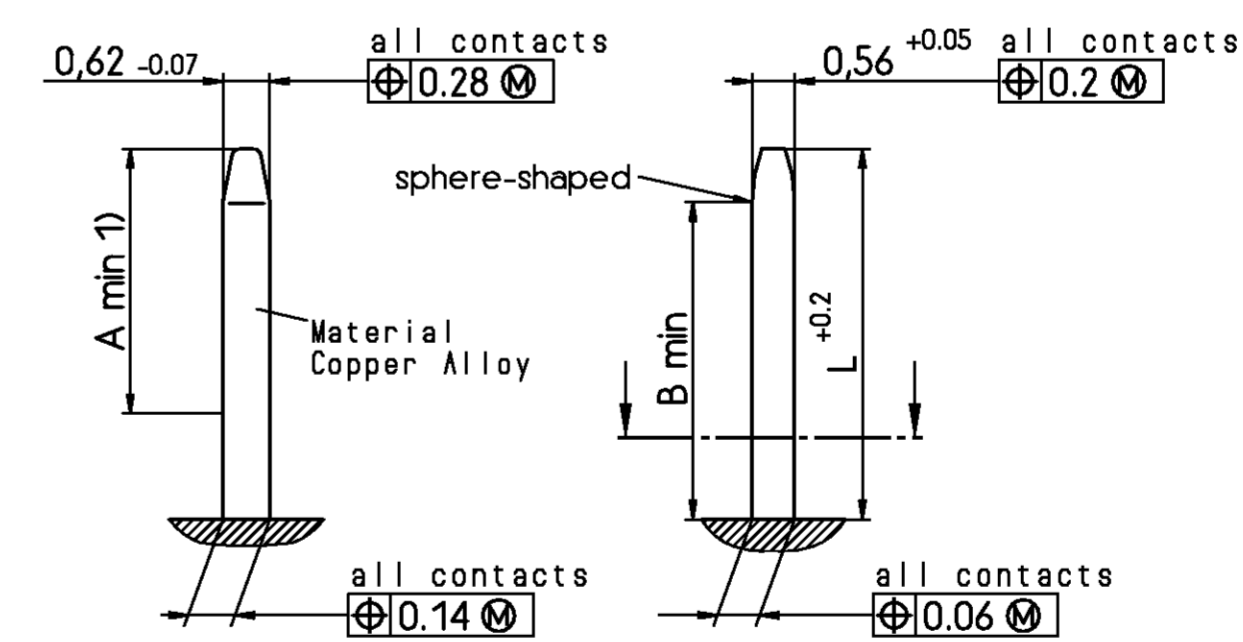

1) Reference area for plating thickness as used in table

	L	A	B
normal contacts	4.8	3.5	4.2
pre-mating contacts	5.8	4.5	5.2

V42254-B1\*\*\*-M\*\*\*

Performance level	Noble metals	Code
Class I	Pd + Au or Au	1
	Au	4
Class II	Pd + Au or Au	2
	Au	5
Class III	Pd + Au or Au	3

Nickel underlayer :  
Protection Film : HF-grease

Male connector with board locks

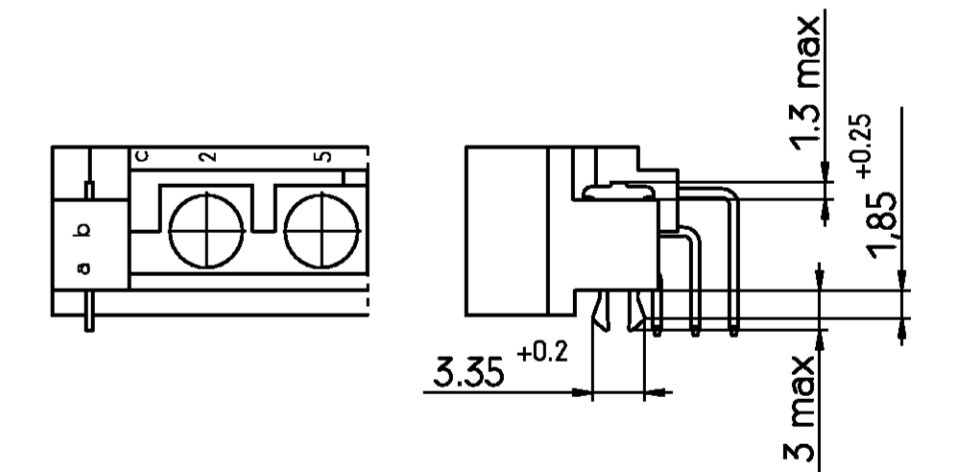

Mounted in PC-boards of 1.5 to 1.8 mm  
Fm < 60 N  
Fr >= 20 N  
Fr >= 200 N, wenn soldered-in

Fm = Mounting force (for 1 connector = 2 Clips)  
Fr = Retention force (for 1 connector = 2 Clips)

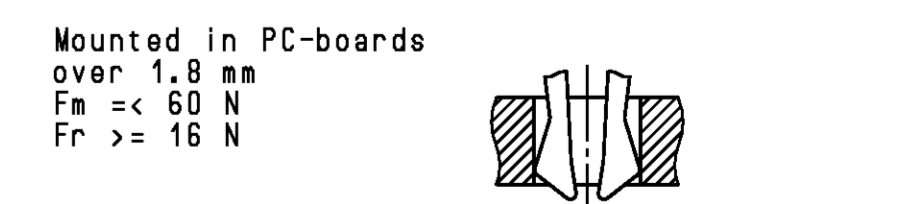



THIS INFORMATION IS CONFIDENTIAL AND PROPRIETARY TO TYCO ELECTRONICS CORPORATION AND ITS WORLDWIDE  
 SUBSIDIARIES AND AFFILIATES. IT MAY NOT BE DISCLOSED TO ANYONE, OTHER THAN TYCO ELECTRONICS PERSONNEL,  
 WITHOUT WRITTEN AUTHORIZATION FROM TYCO ELECTRONICS CORPORATION, HARRISBURG PENNSYLVANIA USA

PROPRIETARY:

Product description code	TE Part Number	Style & Number of Positions	Termination posts	Loaded Rows	Standard Pre-Mating 1 mm 1)	Performance Level	Board Locks	
V42254-B1100-M120	<del>2-1393644-2</del>	M12 + 4	right-angle solder leads	every row , every pitch	No	1	No	
V42254-B1100-M600	<del>2-1393644-7</del>	M60 + 4	right-angle solder leads	every row , every pitch	No	1	No	SUPERSEDED BY 1-1393645-0
V42254-B1102-M600	<del>3-1393644-9</del>	M60 + 4	4,5mm straight solder leads	every row , every pitch	No	1	No	OBSOLETE
V42254-B1135-M120	<del>4-1393644-1</del>	M12 + 4	solder lugs	every row , every pitch	No	1	No	
V42254-B1135-M600	<del>4-1393644-3</del>	M60 + 4	solder lugs	every row , every pitch	No	1	No	
V42254-B1200-M120	<del>1393645-2</del>	M12 + 4	right-angle solder leads	every row , every pitch	No	2	No	
V42254-B1200-M600	1-1393645-0	M60 + 4	right-angle solder leads	every row , every pitch	No	2	No	
V42254-B1200-M603	1-1393645-1	M60 + 4	right-angle solder leads	row a+c , every pitch	No	2	No	
V42254-B1200-M603B	<del>1-1393645-2</del>	M60 + 4	right-angle solder leads	row a+c , every pitch	No	2	No	2)
V42254-B1200-M613	<del>1-1393645-3</del>	M60 + 4	right-angle solder leads	row a+c , every pitch	No	2	Yes	SUPERSEDED BY 1-1393645-1
V42254-B1202-M120	<del>4-1393645-0</del>	M12 + 4	4,5mm straight solder leads	every row , every pitch	No	2	No	OBSOLETE
V42254-B1235-M120	<del>4-1393645-9</del>	M12 + 4	solder lugs	every row , every pitch	No	2	No	
V42254-B1235-M600	<del>5-1393645-0</del>	M60 + 4	solder lugs	every row , every pitch	No	2	No	
V42254-B1240-M600	<del>6-1393645-1</del>	M60 + 4	13mm straight wire-wrap pins	every row , every pitch	No	2	No	

2) According to BT 236 level 2.  
 1) First and last contact of each loaded row is  
 a pre mating (make first / break last) contact.

Active part numbers.  
 Contact TE for other configuration availability

				SCALE	WEIGHT
				MATERIAL	
DATE	21.04.89	PART NAME		PIN Assembly Eurocard, Type M	
NAME	Vanbesien	+ 4 Special Contacts and short versions			
DEP.	PD COM	PART NO.		V42254-B1***-M6***-*-7626	
TOLERANCE UNLESS SPECIFIED OTHERWISE		SHT.		2-	
C4	SEE SHEET 1	Customer Drawing Nr. C 2-1393644-2		OF 2	
REV.	CHANGE ORDER	DATE	APP.		