

Verpackt in Gurtverpackung
Tape on Reel Packaging
Verpackungseinheit: 420 Stück
Packaging unit: 420 pcs

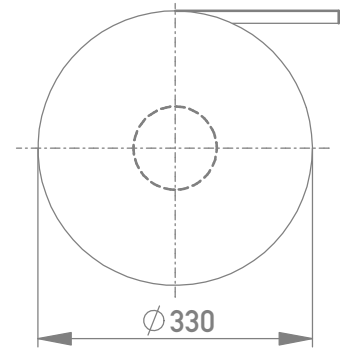

Abspulrichtung - Reel off Direction

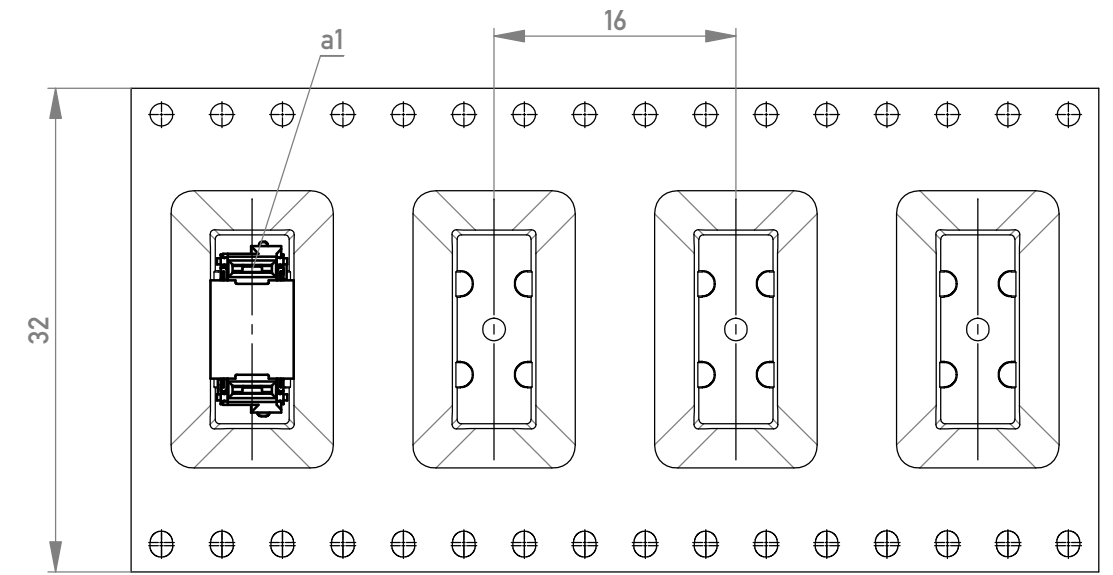
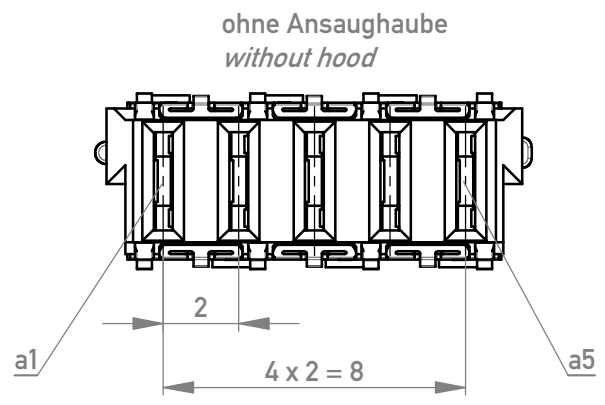
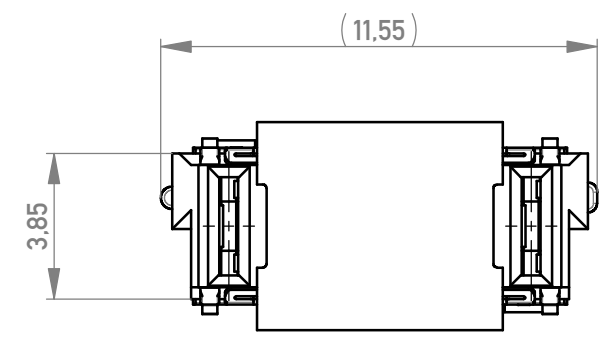

Leiterplatten-Layout Vorschlag / PCB-layout proposal

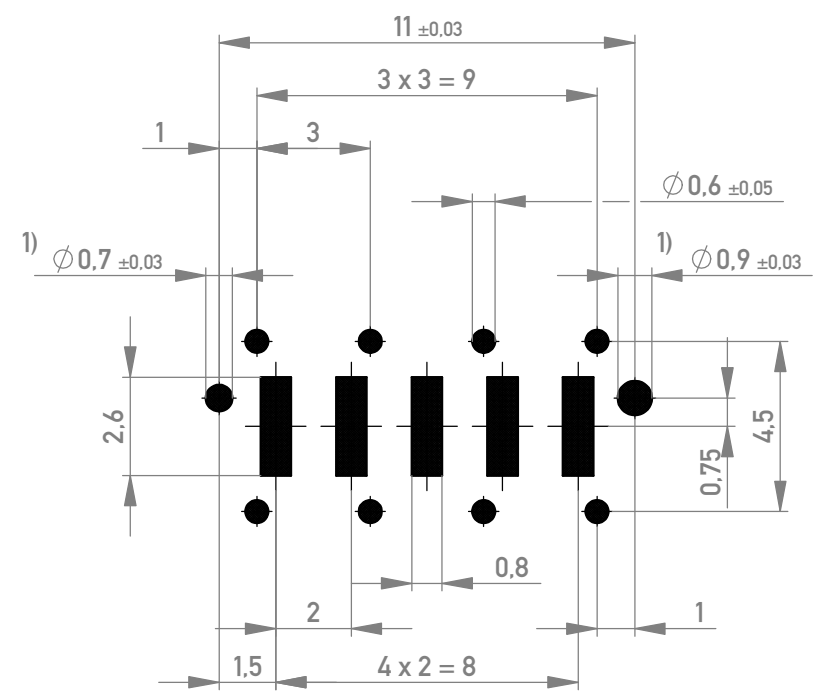

Anforderungsstufe 1
Performance Level 1

Kontaktbereich vergoldet
Mating Area gold plating

Anschlussbereich verzinkt 4-6µm
Terminal Area 4-6µm tin plating

Koplanarität der Anschlüsse ≤ 0,1mm
Coplanarity Area of Termination ≤ 0,1mm

Weitergabe sowie Vervielfältigung dieses Dokuments, Verwertung und Mitteilung seines Inhalts sind verboten, soweit nicht ausdrücklich gestattet. Zuwiderhandlungen verpflichten zu Schadenersatz. Alle Rechte für den Fall der Patent-, Gebrauchsmuster- oder Geschmacksmusterertragung vorbehalten. The reproduction, distribution and utilization of this document as well as the communication of its contents to others without express authorization is prohibited. Offenders will be held liable for the payment of damages. All rights reserved in the event of the grant of a patent, utility model or design.

Die deutsche Version dieser Zeichnung dient nur zur Erleichterung der Handhabung. Bei Abweichungen von dem englischen Original gilt das englische Original. The german version of this drawing has been offered for convenience only and may deviate from the english original. In case of any deviation the English version shall prevail.

Dimension no.	Tolerances	Scale	5:1	Tool-no.
	ISO 8015	Material		
	Date	Name		
	Created 08.02.07	Hörsch		
	Checked 08.02.07	Semilia		
	Approved 19.05.2020	Semilia		
		Federleiste THR, Powerm. 6mm Female Con. THR, Powerm. 6mm		C (1/1)
				A3
g1	TE Migration	18.05.2023	Admin	
Index	Modification Nr.	Date	Name	
		Class		MSPEED

1) Durchmesser des Bohrers / Drill tool