

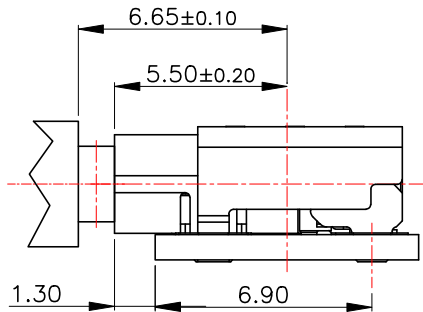

REV.	ECN NO OR DESCRIPTION	REVISED	DATE

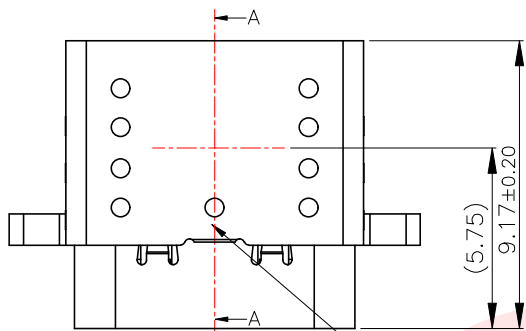

MATED CONDITION(REF.)

NOTES/注释:

- MATERIAL/材料: **SEE TABLE/见下表**
- GENERAL SPECIFICATION/通用特性:
 - COPLANARITY /共面度: **0.10 Max.**
 - CURRENT RATING: 5A / 额定电流: 5安培
 - CONTACT RESISTANCE: 40mΩ MAX (INITIAL).
INSULATION RESISTANCE: 100MΩ Min
接触电阻: 40毫欧最大(初始值) / 绝缘电阻: 100MΩ Min
 - DIELECTRIC WITHSTANDING VOLTAGE: 100 VAC
耐电压: 100伏交流
 - MECHANICAL CHARACTERISTICS:
INSERTION FORCE: 5~20N EXTRACTION FORCE:
8~20N
AFTER DURABILITY EXTRACTION FORCE: 6~20N
力学特性: 初始插入力: 5~20N 拔出力: 8~20N
耐久后拔出力: 6~20N

LASER WELD AREA

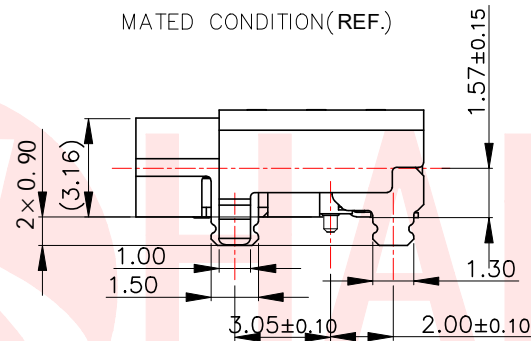
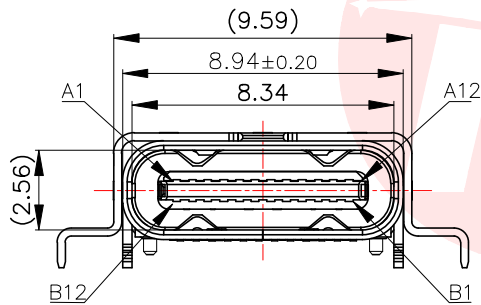

MOUNTING CONDITION(REF.)

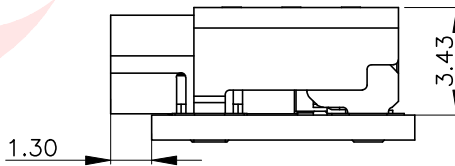

PART NO.
MC-277-EP24ZXX-003

001=镀金1u"
003=镀金3u"
005=镀金5u"
015=镀金15u"
030=镀金30u"

Pin 数:

A1	A2	A3	A4	A5	A6	A7	A8	A9	A10	A11	A12
GND	TX1+	TX1-	Vbus	CC1	D+	D-	SBU1	Vbus	RX2-	RX2+	GND
GND	RX1+	RX1-	Vbus	SBU2	D-	D+	CC2	Vbus	TX2-	TX2+	GND
B12	B11	B10	B9	B8	B7	B6	B5	B4	B3	B2	B1

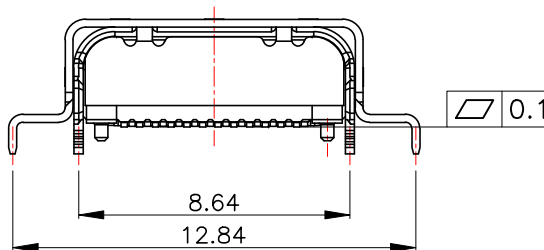
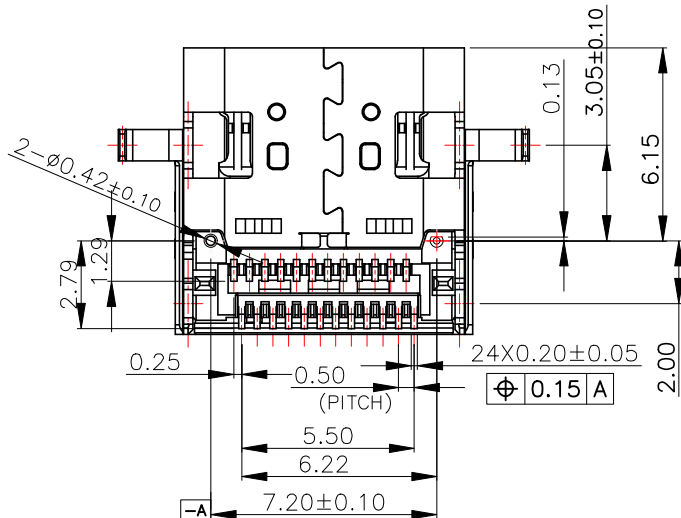

ITEM	DESCRIPTION	Q'TY	MATERIAL	FINISH	REMARK
6	OUT SHELL	1	SUS304	30U" NICKEL PLATING	0.25mm
5	INT SHELL	1	SUS304	30U" NICKEL PLATING	0.3mm
4	MAIN HOUSING	1	HIGH TEMPERATURE	PA9T BLACK	UL94V-0
3	MID PLATE	1	SUS301	RINSE	0.15mm
2	BOTTOM TERMINAL	1	COPPER ALLOY	MATING SIDE:SEE PART NO; SOLDER TAIL:GOLD FLASH, 30u" NICKEL OVERALL.	0.12mm
1	TOP TERMINAL	1	COPPER ALLOY		0.12mm

UNLESS OTHERWISE SPECIFIED TOLERANCES



东莞市汉博电子科技有限公司
DONGGUAN HANBO TECHNOLOGY CO., LTD

DECIMALS:	ANGLES:	TITLE	TYPE C 4.0母座有后盖双壳双贴SMT板上CH=1.57,L=9.17虎脚长0.9		
X :±0.30	X :±2°	DWN	xiong	PART NO. MC-277-EP24Z09-003	
X.X :±0.20	X.X :±1°	CHKD	lee	SCALE:1:1	UNIT: mm
X.XX :±0.10		APVD	wang	SIZE: A4	SHEET:10F 1

CUSTOMER COPY



REV.	ECN NO OR DESCRIPTION	REVISED	DATE

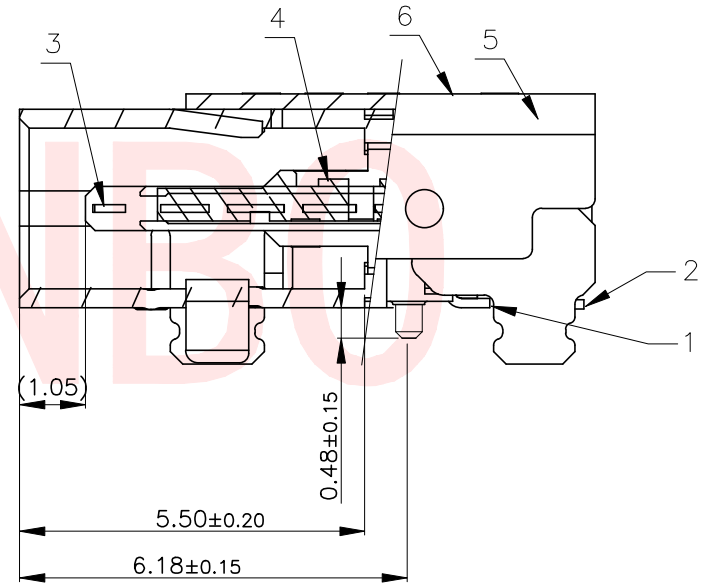
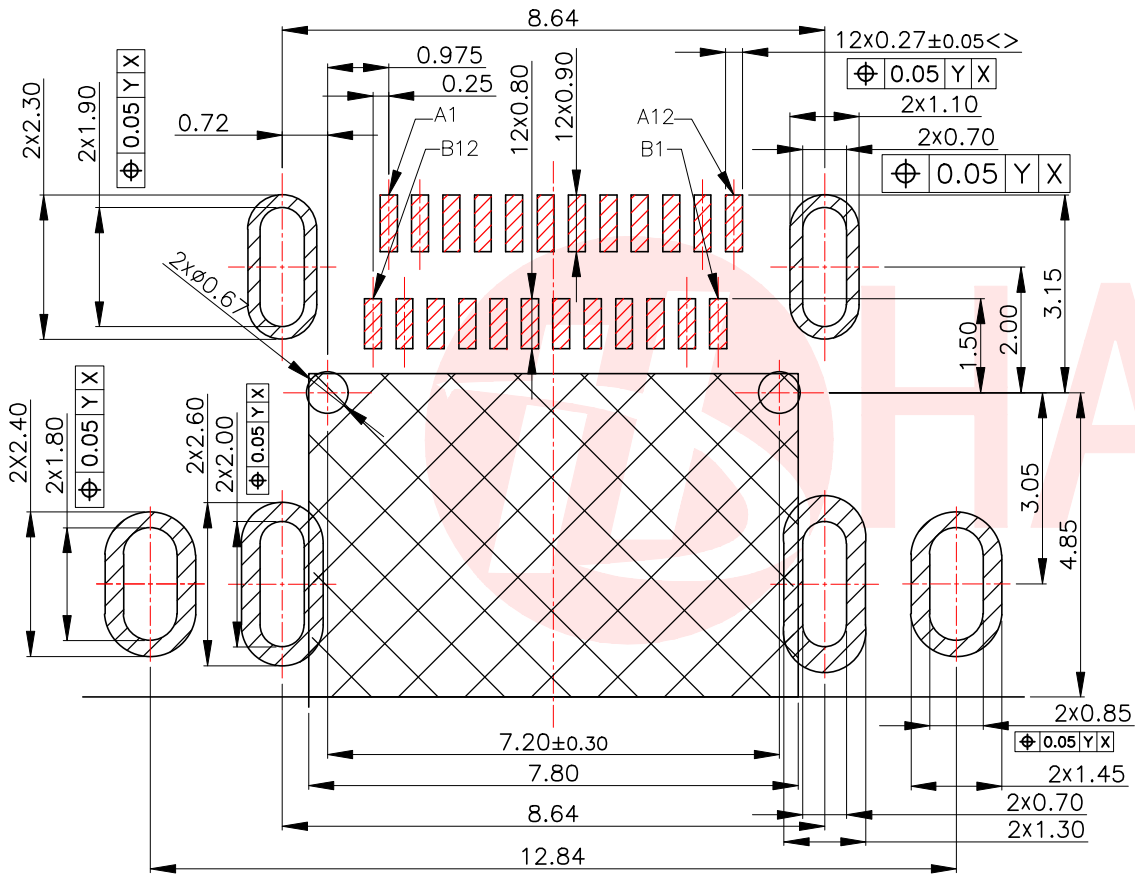

SECTION A-A(剖视图A-A)
SCALE 2:1 (比例 2:1)

Recommended PCB Layout(Top View)/推荐的PCB布局(前视图)
General Tolerances: ± 0.05 /一般公差: ± 0.05

UNLESS OTHERWISE SPECIFIED TOLERANCES



东莞市汉博电子科技有限公司
DONGGUAN HANBO TECHNOLOGY CO., LTD

DECIMALS: ANGLES:
X : ± 0.30 X : $\pm 2^\circ$
X.X : ± 0.20 X.X : $\pm 1^\circ$
X.XX : ± 0.10

TITLE	TYPE C 4.0母座有后盖双壳双贴SMT板上CH=157,L=9.17壳脚长0.9			
DWN	xiong	PART NO. MC-277-EP24Z09-003		
CHKD	lee	SCALE:1:1	UNIT: mm	
APVD	wang	SIZE: A4	SHEET:10F 1	REV: A4

CUSTOMER COPY



REV.	ECN NO OR DESCRIPTION	REVISED	DATE

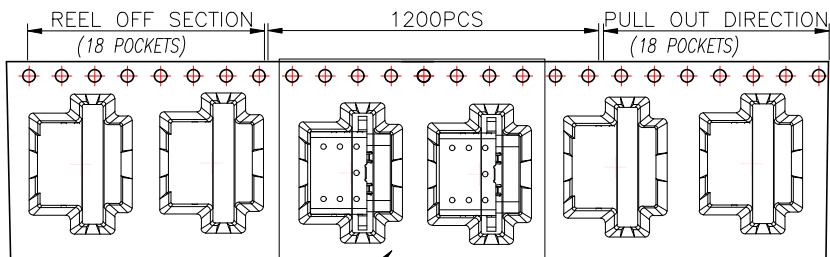

SEE DETAIL X

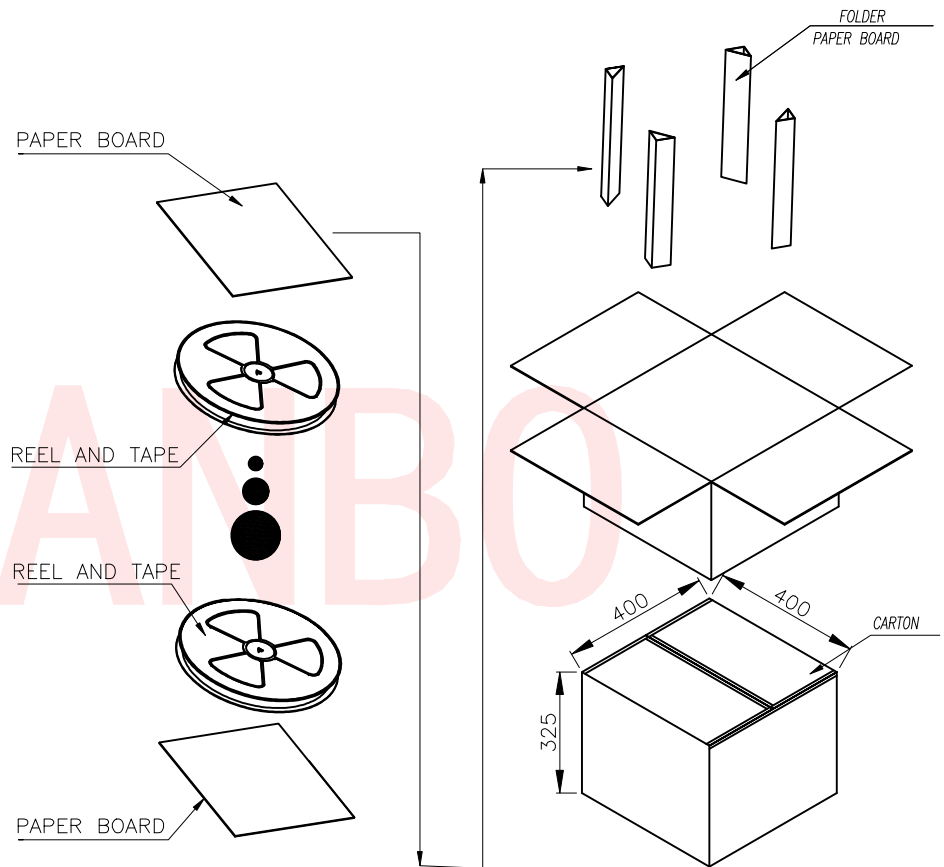
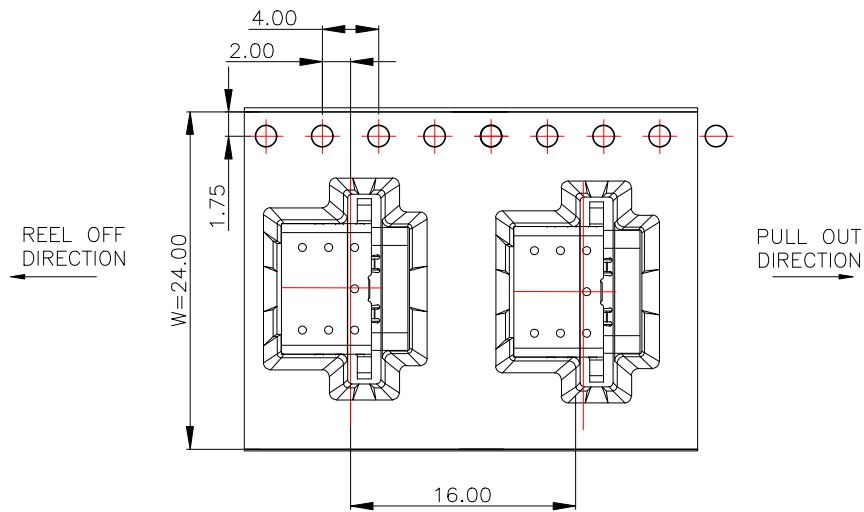
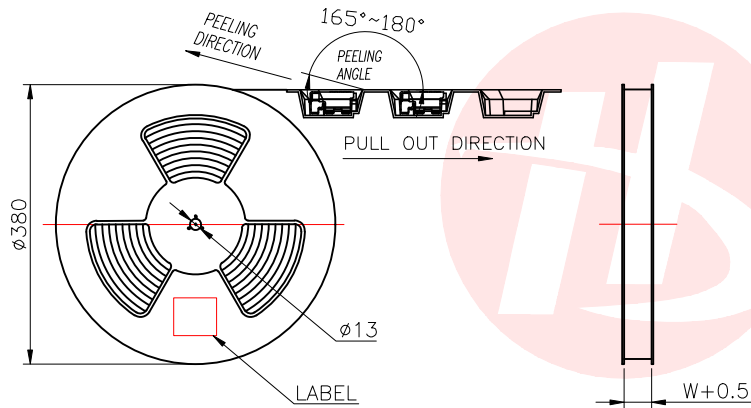

		REEL	CARTON	
CONNECTOR (PCS)		1000	10000	
UNLESS OTHERWISE SPECIFIED TOLERANCES		东莞市汉博电子科技有限公司 DONGGUAN HANBO TECHNOLOGY CO., LTD		
DECIMALS: X :±0.30 X.X :±0.20 X.XX :±0.10		TITLE: TYPE C 4.0母座有后盖双壳双贴SMT板上CH=1.57,L=9.17壳脚长0.9 DWN: xiong PART NO. MC-277-EP24Z09-003 CHKD: lee SCALE:1:1 UNIT: mm APVD: wang SIZE: A4 SHEET:10F 1 REV: A4		
		CUSTOMER COPY		