

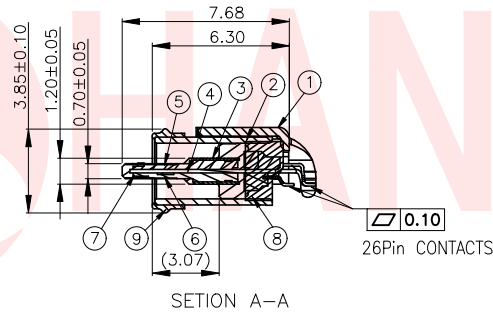

REV.	ECN NO OR DESCRIPTION	REVISED	DATE

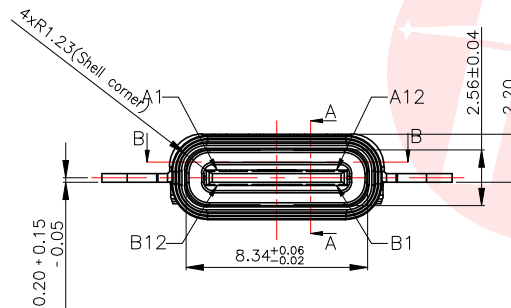
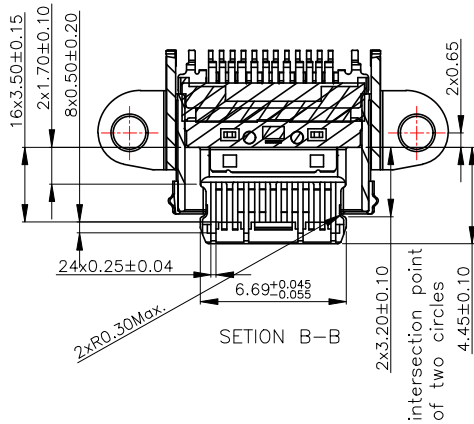
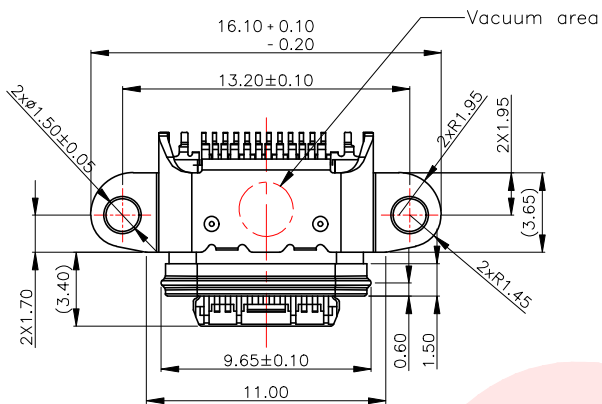

	A1	A2	A3	A4	A5	A6	A7	A8	A9	A10	A11	A12
Mid Plate	GND	TX1+	TX1-	VBus	CC1	D+	D-	SBU1	VBus	RX2-	RX2+	GND
	GND	RX1+	RX1-	VBus	SBU2	D-	D+	CC2	VBus	TX2-	TX2+	GND
	B12	B11	B10	B9	B8	B7	B6	B5	B4	B3	B2	B1

Remark:

- MECHANICAL PERFORMANCE,
  - 1-1.INSERTION FORCE: 5~20N.
  - 1-2.EXTRACTION FORCE: 8~20N INITIAL,6~20N AFTER TEST;
  - 1-3.DURABILITY: 10000 CYCLES.
- ELECTRICAL PERFORMANCE,
  - 2-1. CURRENT RATING:5A MIN FOR VBUS,0.25A MIN FOR OTHERS  
VOLTAGE RATING: 20V MAX.
  - 2-2. LLCR:
  - 2-3.INSULATION RESISTANCE: 100MΩ MIN
  - 2-4.DIELECTRIC WITHSTAND VOLTAGE,AC 100V FOR 1 MINUTE.
- The waterproof grade is IPX8(1.5m depth of water).
- PIN DEFINITION:(GND pins(A1,A12,B1,B12) and Mid Plate should connect together in PCB circuit.)
- Environmental Characteristics
  - Salt Spray: 48H
  - IR Reflow: Peak Temperature 245±5°C (Time:30S)
  - Operating Temperature Range:-30°C to +85°C.
  - Storage Temperature Range: -20°C to +60°C.
  - Relative Humidity: 15~70%RH
  - Storage Life : 6 Months
- Comply to Rohs2.0 & HF.

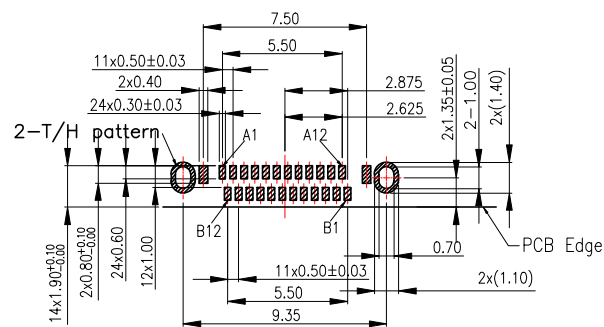
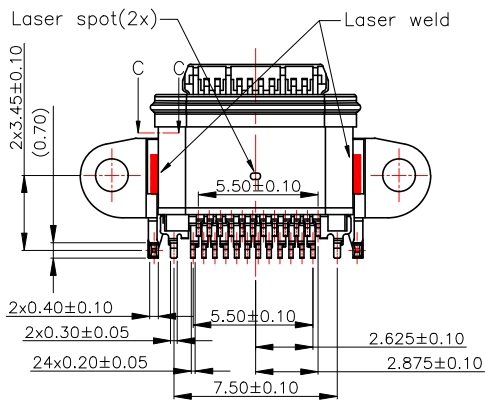

RECOMMENDED PCB LAYOUT  
DEFAULT TOLERANCE:±0.05

9	Liquid Rubber		Si	Color:Black
8	Rubber	1PCS	Si	Color:Black
7	Insertmolding	1PCS	LCP E6808	Color:Black UL94 V-0
6	Bottom Contact	12PCS	C18150-R540, T=0.12	Mating Area: Ni 50u"MIN.+Au 15u" Min.
5	Top Contact	12PCS	C18150-R540, T=0.12	Solder Tails: Ni 50u"MIN.+Au 1u" Min.
4	Mid Plate	1PCS	SUS301R-H, T=0.15	Ni 50u"Min.+Solder area:Au 1u"Min.
3	GND Plate	2PCS	SUS301R-H, T=0.10	None
2	Shell	1PCS	SUS316, T=0.30	Ni:50u" Min.
1	Frame	1PCS	SUS304R-1/2H, T=0.30	Ni:50u" Min.
NO.	Part Name	Q'TY	Material	Finish

UNLESS OTHERWISE SPECIFIED TOLERANCES

东莞市汉博电子科技有限公司  
DONGGUAN HANBO TECHNOLOGY CO., LTD

DECIMALS:	ANGLES:	TITLE	USB TYPE C WATERPROOF FEMALE MID-Mount Dual-Row SMT TYPE		
X :±0.30	X :±2°	DWN	xiong	PART NO. MC-2406FLS	
X.X :±0.20	X.X :±1°	CHKD	lee	SCALE:1:1	UNIT: mm
X.XX :±0.10		APVD	wang	SIZE: A4	SHEET:10F 1
REV: A4					
CUSTOMER COPY					



REV.	ECN NO OR DESCRIPTION	REVISED	DATE

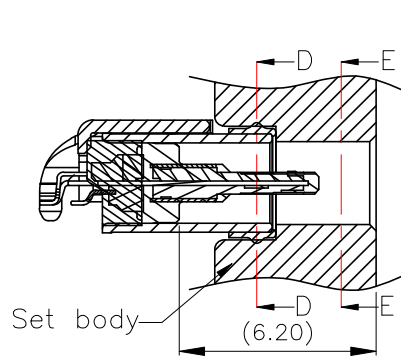

RECOMMENDED SET BODY SIDE HOLE SHAPE

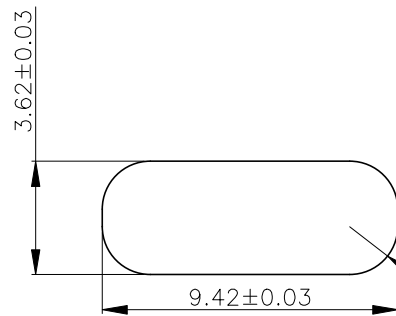

SECTION D-D

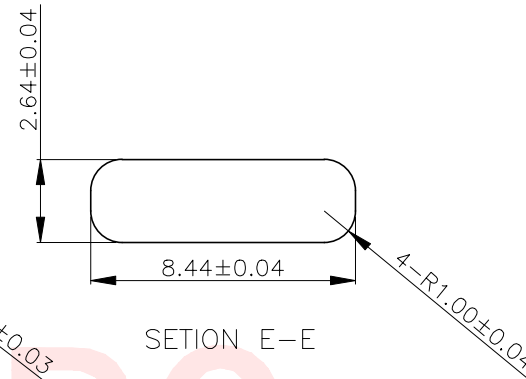

SECTION E-E

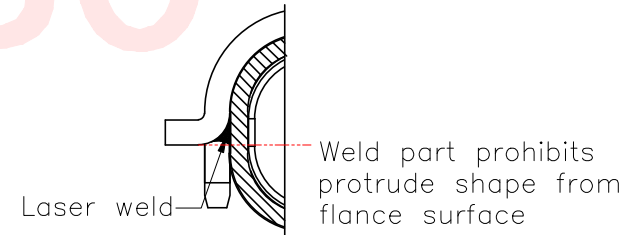
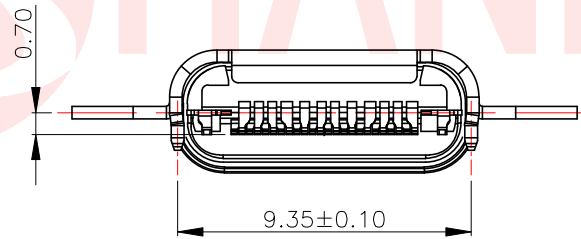
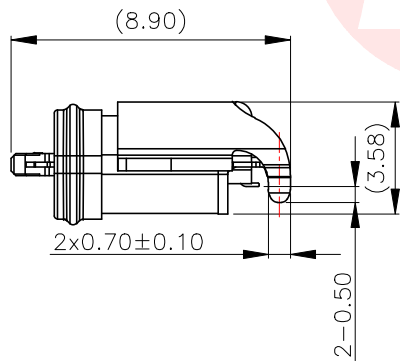

SECTION C-C  
SCALE 2:1

UNLESS OTHERWISE SPECIFIED TOLERANCES

DECIMALS:	ANGLES:
X :±0.30	X :±2°
X.X :±0.20	X.X :±1°
X.XX :±0.10	

东莞市汉博电子科技有限公司  
DONGGUAN HANBO TECHNOLOGY CO., LTD

TITLE	USB TYPE C WATERPROOF FEMALE MID-Mount Dual-Row SMT TYPE			
DWN	xiong	PART NO. MC-2406FLS		
CHKD	lee	SCALE:1:1	UNIT: mm	
APVD	wang	SIZE: A4	SHEET:10F 1	REV: A4

CUSTOMER COPY



REV.	ECN NO OR DESCRIPTION	REVISED	DATE

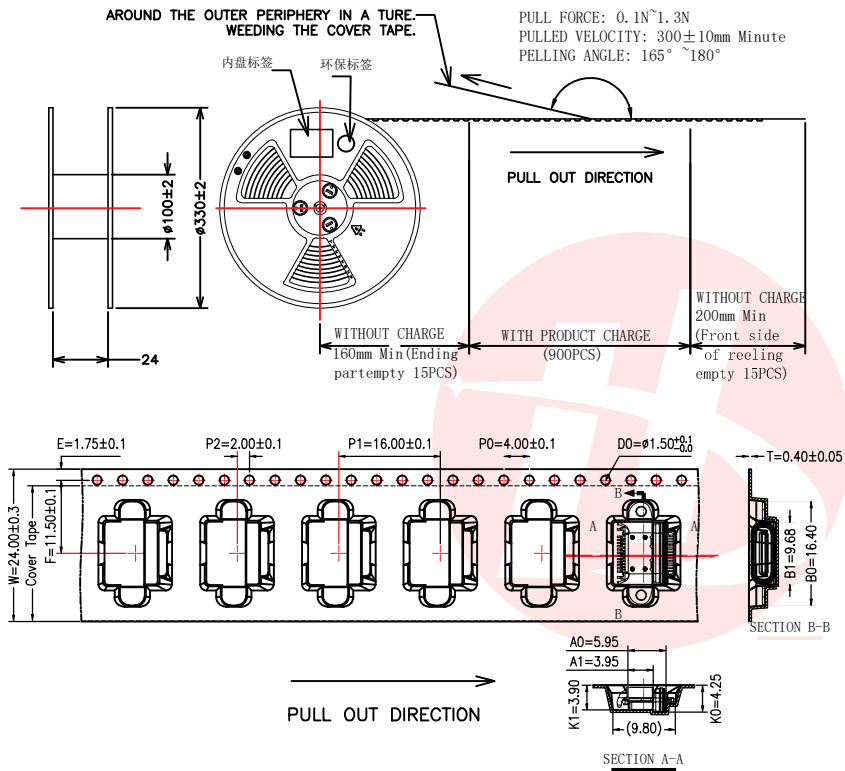

**包装规范说明:**

1. 如图所示首先CARRIER TAPE (载带) 需先预留15PCS空格后方可置入成品,并附COVER TPAE(上带)覆盖于上,再配合带装机自动卷绕于REEL(塑胶卷轴)收料。  
As shown from picture, the initial starting carrier need to be emptied for 15 pcs, then put connector on Inth carrier; Then cover it with Cover Tape, and Reeling it with Reel auto machine.
2. 在定量包装完成后,前端CARRIER TAPE亦需预留15PCS空格,而COVER TPAE配合CARRIER TYPE长度覆盖后,并须再超出200mm以上,最后以胶纸贴固,最外层用保护带缠绕一圈,并于REEL盘上方贴好标签。  
In the end of the Reel, need to empty 15 pcs carrier tape; After covering the carrier, then the Cover Tape need to be 200mm longer, and use tape to fix the cover tape to the reel. Put unalified Label" on the tape.
3. 注意:COVER TAPE不可浮起或有贴附不顺,歪斜及成品放置方向错误之现象。  
Attention: no deformation of Cover Tape is allowed (protruded plastic, or not smooth, bednt or product is wrong positioned)
4. 在纸箱内左右,前后侧各放入一块三角卡板,每个PE袋中装入5个REEL盘,并在PE袋中放入2PCS干燥剂,用胶带封好,在每个纸箱内装入10PCS卷盘,共2叠.上下各垫一张平卡, 盖上箱盖后以胶带封箱,于侧位置贴好标签。  
Inside of carton, at left and right side, put triangle fixed card; Put5Reels to PE bag, and put 2 bags of desiccant inside the PE bag. Each carton has 10 reels. Put "Delivery label" on side of the carton.
5. 零箱部分, 出货时须用缓冲物填满。  
The fractional box must be filled by cushion before shipment.

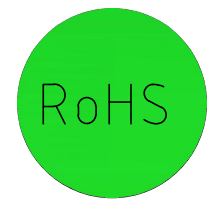
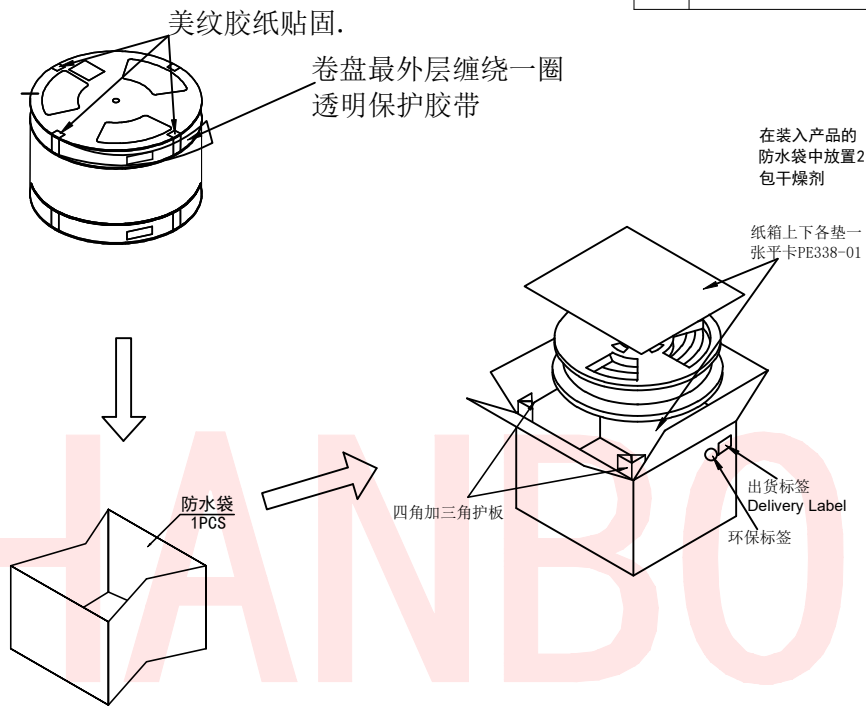

环保标签 (ø25MM)  
Rohs Label

NO.	包材名称 Items	包材料号 Item no	用量 Usage	适用类别 Series	备注 / Remark
①	纸箱 Carton		1		350*350*310mm
②	PE Bag		2		600*600*0.05mm
③	carrier tape		10		W=24mm PET 透明14.88M/R
④	cover tape				W=21.3MM,200m/r透明色
⑤	塑胶卷轴 Plastic Reel		10		Ø330mm,W=30mm
⑥	干燥剂 Desiccant		4		
⑦	环保标签 Rohs Label		11		
⑧	合格标签 Qualified Label		10		80*35mm
⑨	出货标签 Delivery Label		1		80*50mm
⑩	保护带 Protect tape	PB284	1		W24*400M/R

UNLESS OTHERWISE SPECIFIED TOLERANCES

**东莞市汉博电子科技有限公司**  
DONGGUAN HANBO TECHNOLOGY CO., LTD

TITLE	USB TYPE C WATERPROOF FEMALE MID-Mount Dual-Row SMT TYPE		
DWN	xiong	PART NO. MC-2406FLS	
CHKD	lee	SCALE: 1:1	UNIT: mm
APVD	wang	SIZE: A4	SHEET: 10F 1
REV: A4			

CUSTOMER COPY