

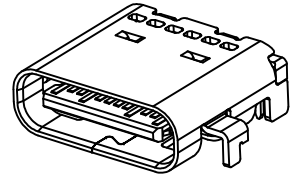

REV.	ECN NO OR DESCRIPTION	REVISED	DATE

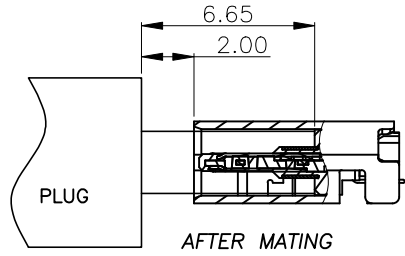
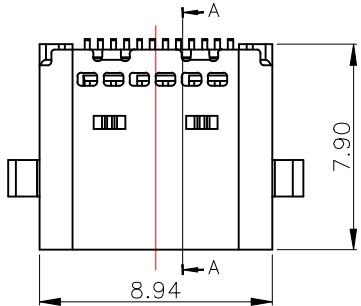

NOTE:

- MATERIAL SPECIFICATION:**
 - HOUSING: HIGH TEMPERATURE RESISTANT PLASTIC, UL94 V-0.
 - CONTACTS: COPPER ALLOY
 - MID PLATE: STAINLESS STEEL
 - FRONT SHELL: STAINLESS STEEL
 - EMI PLATE: STAINLESS STEEL
- PLATING SPECIFICATION:**
 - CONTACTS:
 - Ni 50u" MIN. UNDER PLATED OVER ALL.
 - Au PLATED ON THE FUNCTIONAL AREA OF CONTACT. (GOLD PLATING THICKNESS FOLLOW THE P/N)
 - PLATING SPECIFICATIONS OF THE SOLDER AREA FOLLOW THE P/N
 - FRONT SHELL:
 - Ni 30u" MIN. UNDER PLATED OVER ALL.
 - MID PLATE:
 - Ni 30u" MIN. UNDER PLATED OVER ALL.
 - Sn 80u" MIN. PLATED OVER ALL
 - EMI PLATE:
 - CLEAR ONLY
- MECHANICAL PERFORMANCE,**
 - INSERTION FORCE: 0.5~2.0kgf.
 - REMOVAL FORCE: 0.8kgf~2.0kgf.
 - DURABILITY: 10000 CYCLES.
- ELECTRICAL PERFORMANCE,**
 - CURRENT RATING: 5.0A
VOLTAGE RATING: 5.0V
 - LLCR:
 - VBUS & GND PINS AND OTHER PINS: 40ma/PIN MAX.
 - LLCR MAX. CHANGE OF ALL PINS: 10me.
 - INSULATION RESISTANCE: 100MΩ MIN
 - DIELECTRIC WITHSTAND VOLTAGE, AC 100V FOR 1 MINUTE.
- ENVIRONMENTAL PERFORMANCE:**
 - OPERATING TEMPERATURE: -25°C~+85°C.
- IR REFLOW:**
 - THE PEAK TEMPERATURE ON THE BOARD SHALL BE MAINTAINED FOR 10 SECONDS AT 260°C.

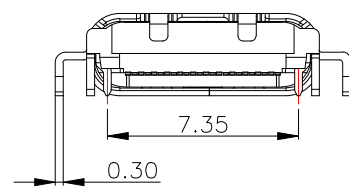
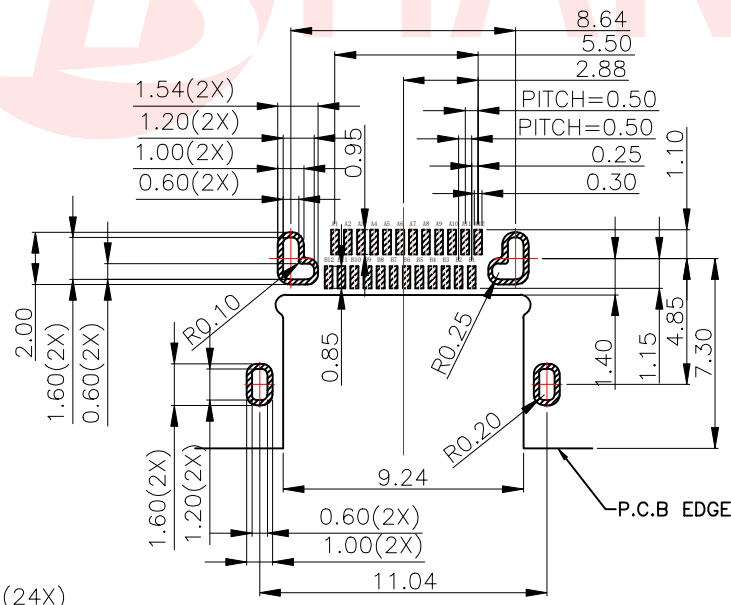
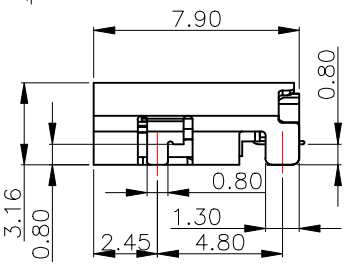
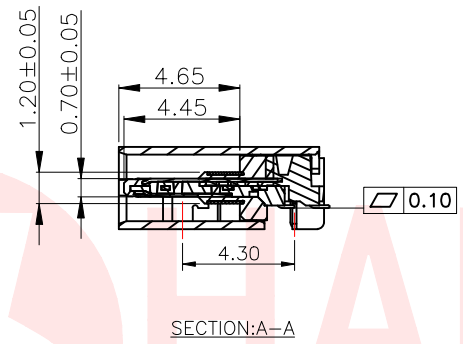
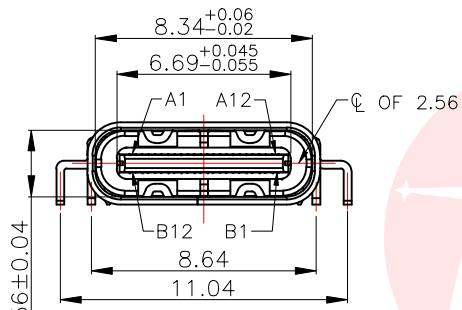

USB TYPE-C PIN ASSIGNMENTS			
PIN NUMBER	SIGNAL NAME	PIN NUMBER	SIGNAL NAME
A1	GND	B12	GND
A2	Txp1	B11	Rxp1
A3	Txn1	B10	Rxn1
A4	VBUS	B9	VBUS
A5	CC1	B8	SBU2
A6	Dp1	B7	Dn2
A7	Dn1	B6	Dp2
A8	SBU1	B5	CC2
A9	VBUS	B4	VBUS
A10	Rxn2	B3	Txn2
A11	Rxp2	B2	Txp2
A12	GND	B1	GND

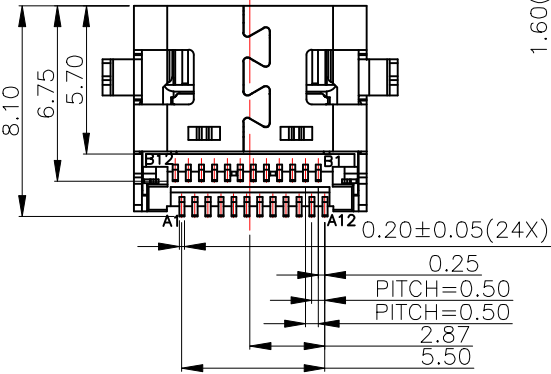

RECOMMENDED PCB LAYOUT(TOP VIEW)
THICKNESS 0.60MM; DEFAULT TOLERANCE: ±0.05

UNLESS OTHERWISE SPECIFIED TOLERANCES

DECIMALS:	ANGLES:
X : ±0.30	X : ±2°
X.X : ±0.20	X.X : ±1°
X.XX : ±0.10	

东莞市汉博电子科技有限公司
DONGGUAN HANBO TECHNOLOGY CO., LTD

TITLE	USB CF 24PIN SMT TYPE MID-MOUNT 0.8mm		
DWN	xiong	PART NO. MC-210-C08-EP24	
CHKD	lee	SCALE: 1:1	UNIT: mm
APVD	wang	SIZE: A4	SHEET: 10F 1 REV: A4
CUSTOMER COPY			



REV.	ECN NO OR DESCRIPTION	REVISED	DATE

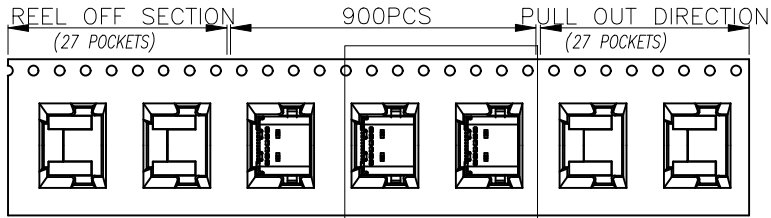

SEE DETAIL X

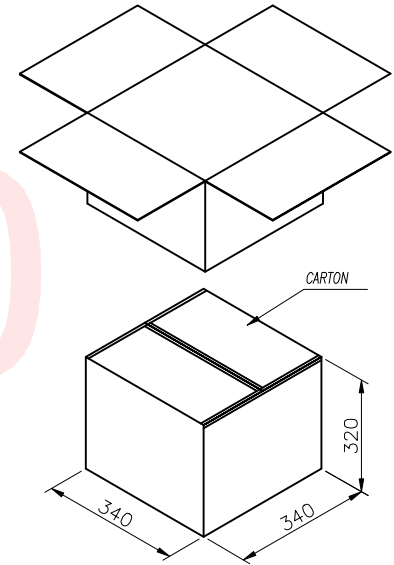
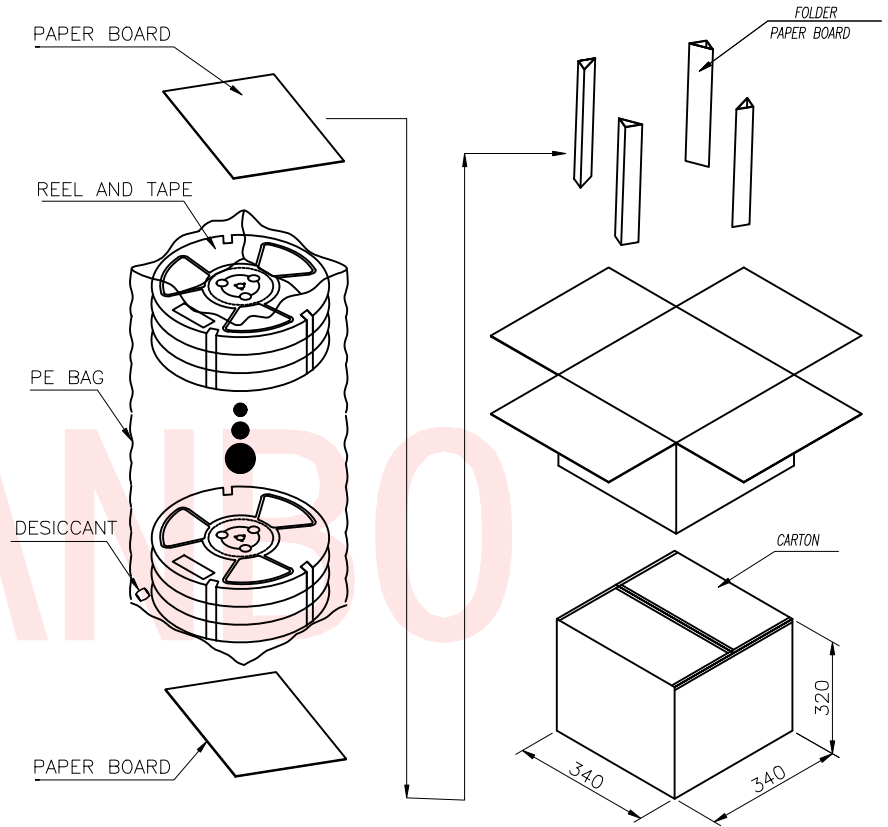
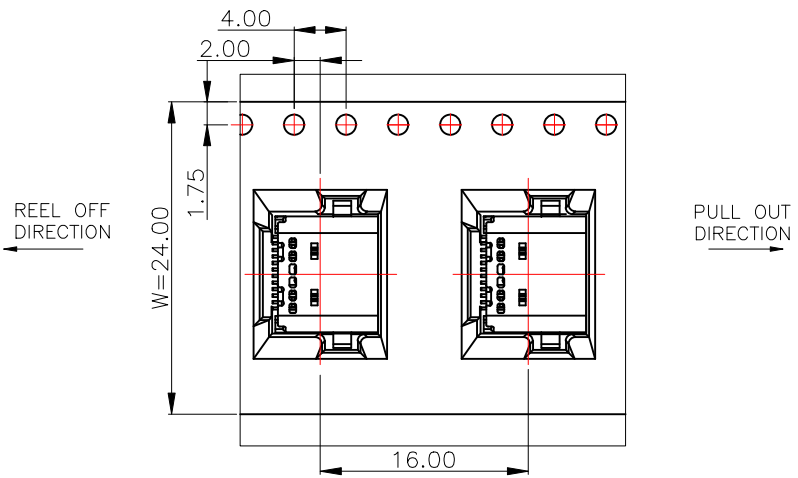
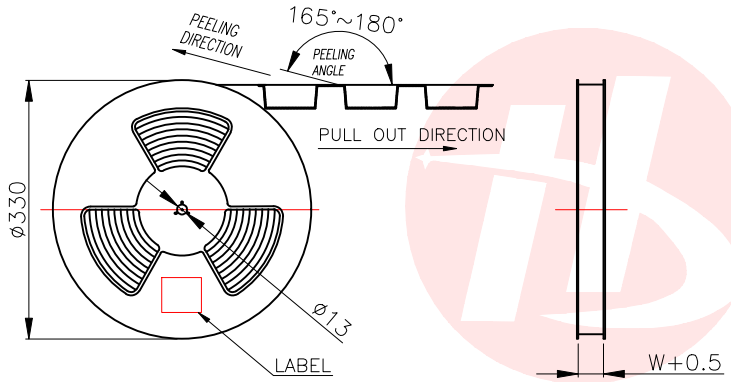

		REEL	CARTON
CONNECTOR (PCS)		900	9000
UNLESS OTHERWISE SPECIFIED TOLERANCES		东莞市汉博电子科技有限公司 DONGGUAN HANBO TECHNOLOGY CO., LTD	
DECIMALS: ANGLES:		TITLE USB CF 24PIN SMT TYPE MID-MOUNT 0.8mm	
X :±0.30	X :±2°	DWN	xiong PART NO. MC-210-C08-EP24
X.X :±0.20	X.X :±1°	CHKD	lee SCALE:1:1 UNIT: mm
X.XX :±0.10		APVD	wang SIZE: A4 SHEET:10F 1 REV: A4
CUSTOMER COPY			