

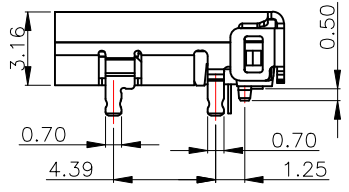

REV.	ECN NO OR DESCRIPTION	REVISED	DATE

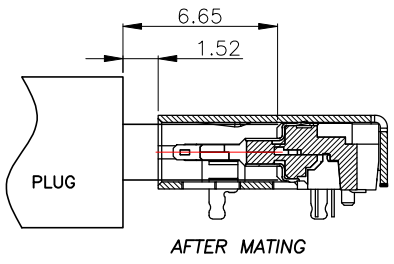

- NOTE:**
- MATERIAL SPECIFICATION:**
 - HOUSING: PA9T COLOR SEE TABLE 1, UL94 V-0.
 - CONTACTS: COPPER ALLOY (C18150)
 - MID PLATE & SPRING: STAINLESS STEEL (SUS301)
 - FRONT SHELL: STAINLESS STEEL (SUS304)
 - PLATING SPECIFICATION:**
 - CONTACTS:**
 - Ni 50u" MIN. UNDER PLATED OVER ALL.
 - Au PLATED ON THE FUNCTIONAL AREA OF CONTACT. (GOLD PLATING THICKNESS FOLLOW THE P/N)
 - FRONT SHELL & COVER:**
 - Ni 30u" MIN. UNDER PLATED OVER ALL.
 - MID PLATE & EMI SPRING:**
 - CLEAR ONLY
 - MECHANICAL PERFORMANCE:**
 - INSERTION FORCE: 0.5~2.0kgf.
 - REMOVAL FORCE: 0.8kgf~2.0kgf.
 - DURABILITY: 10000 CYCLES.
 - ELECTRICAL PERFORMANCE:**
 - CURRENT RATING: 3.0A
VOLTAGE RATING: 5.0V
 - LLCR:
 - VBUS & GND PINS AND OTHER PINS: 40mA/PIN MAX.
 - LLCR MAX. CHANGE OF ALL PINS: 10mA.
 - INSULATION RESISTANCE: 100MΩ MIN
 - DIELECTRIC WITHSTAND VOLTAGE, AC 100V FOR 1 MINUTE.
 - ENVIRONMENTAL PERFORMANCE:**
 - OPERATING TEMPERATURE: -25°C~+85°C.
 - IR REFLOW:**
 - THE PEAK TEMPERATURE ON THE BOARD SHALL BE MAINTAINED FOR 10 SECONDS AT 260°C.

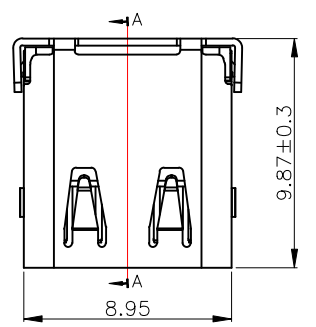
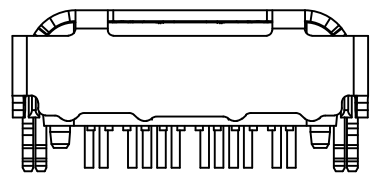
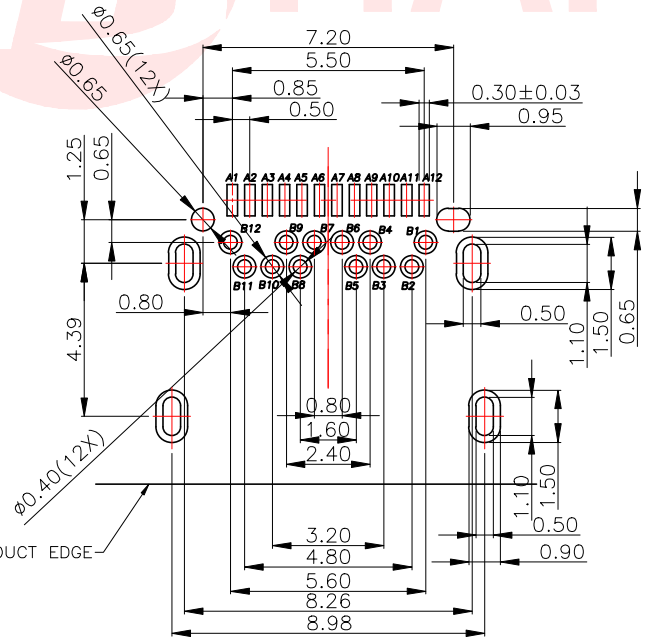
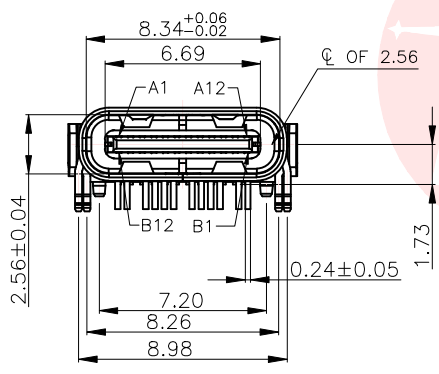
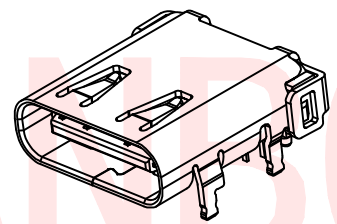
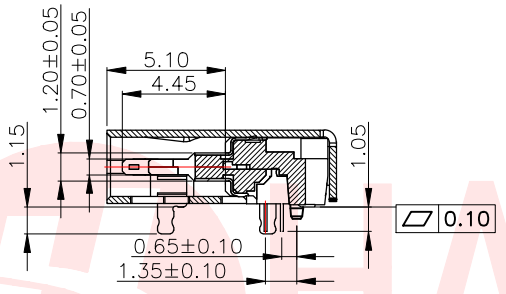

USB TYPE-C PIN ASSIGNMENTS

PIN NUMBER	SIGNAL NAME	PIN NUMBER	SIGNAL NAME
A1	GND	B12	GND
A2	TXp1+	B11	RXp1+
A3	TXn1-	B10	RXn1-
A4	Vbus	B9	Vbus
A5	CC1	B8	SBU2
A6	Dp1	B7	Dn2
A7	Dn1	B6	Dp2
A8	SBU1	B5	CC2
A9	Vbus	B4	Vbus
A10	RXn2-	B3	TXn2-
A11	RXp2+	B2	TXp2+
A12	GND	B1	GND

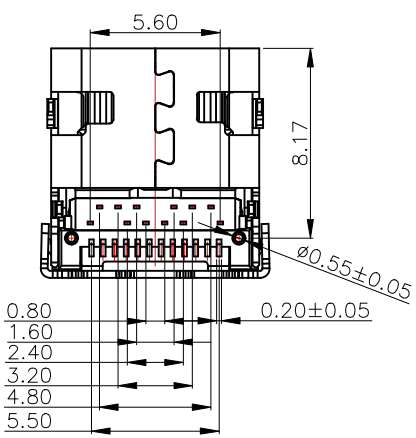

SCALE 1.5:1
RECOMMENDED PCB LAYOUT (TOP VIEW)
THICKNESS 0.8 MM; DEFAULT TOLERANCE: ±0.05

UNLESS OTHERWISE SPECIFIED TOLERANCES

DECIMALS:	ANGLES:
X : ±0.30	X : ±2°
X.X : ±0.20	X.X : ±1°
X.XX : ±0.10	

东莞市汉博电子科技有限公司
DONGGUAN HANBO TECHNOLOGY CO., LTD

TITLE	USB CF 24PIN TYPE DIP+SMT CONN, L=9.87		
DWN	xiong	PART NO. MC-208C-EP24	
CHKD	lee	SCALE: 1:1	UNIT: mm
APVD	wang	SIZE: A4	SHEET: 1 OF 1
REV: A4			
CUSTOMER COPY			



REV.	ECN NO OR DESCRIPTION	REVISED	DATE

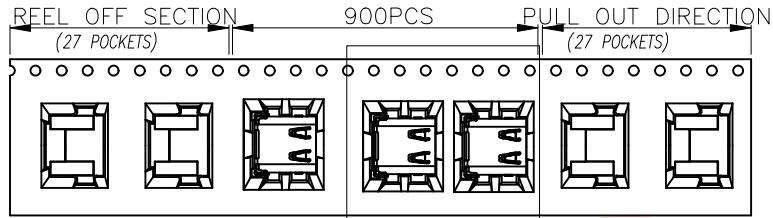

SEE DETAIL X

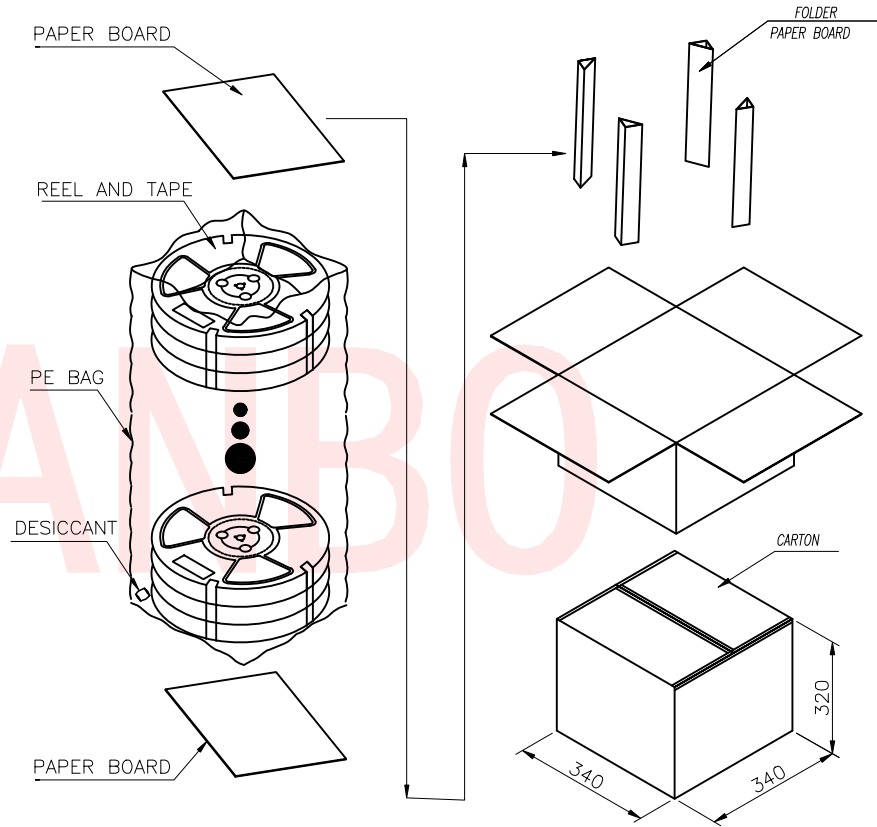
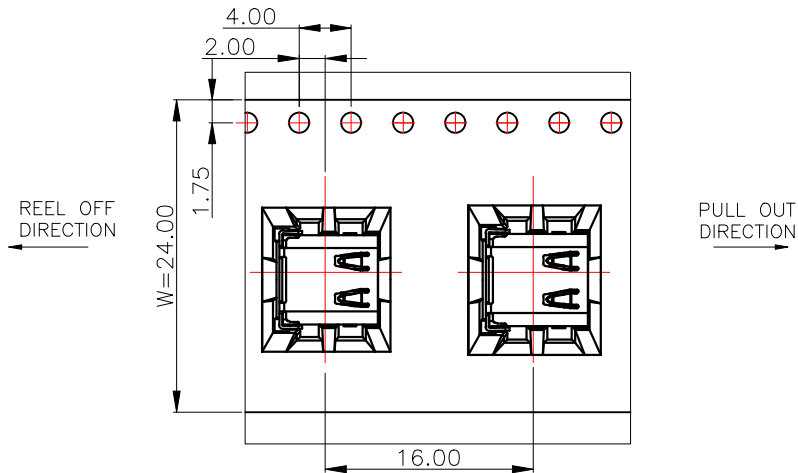
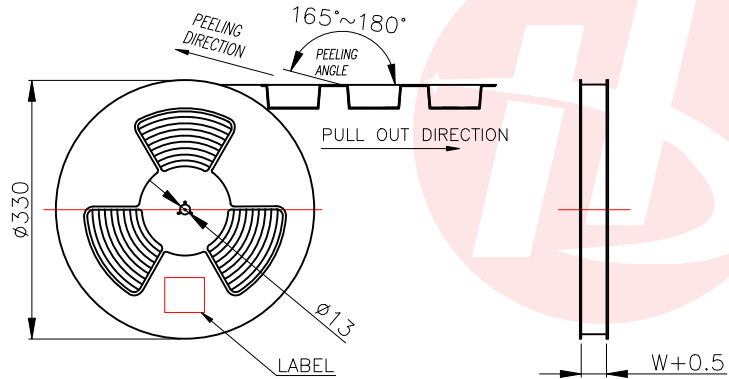

		REEL	CARTON
CONNECTOR (PCS)		1000	10000
UNLESS OTHERWISE SPECIFIED TOLERANCES		东莞市汉博电子科技有限公司 DONGGUAN HANBO TECHNOLOGY CO., LTD	
DECIMALS: ANGLES:		TITLE USB CF 24PIN TYPE DIP+SMT CONN, L=9.87	
X :±0.30	X :±2°	DWN	xiong PART NO. MC-208C-EP24
X.X :±0.20	X.X :±1°	CHKD	lee SCALE:1:1 UNIT: mm
X.XX :±0.10		APVD	wang SIZE: A4 SHEET:10F 1 REV: A4
CUSTOMER COPY			