

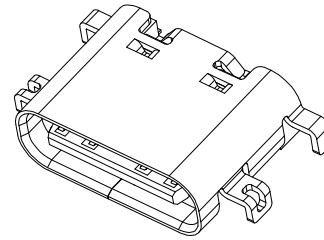

REV.	ECN NO OR DESCRIPTION	REVISED	DATE

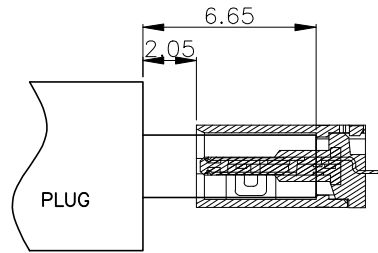

AFTER MATING

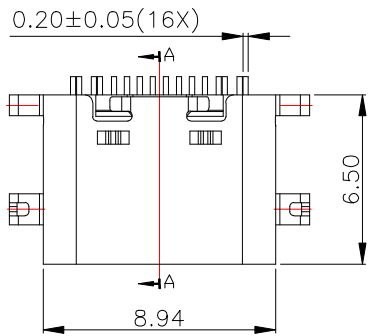
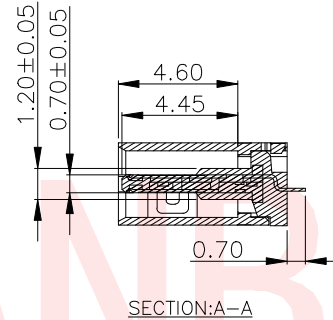
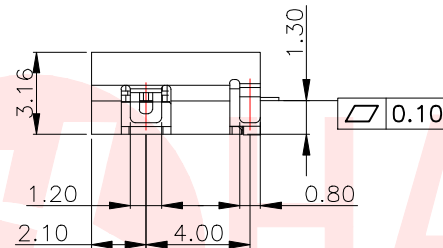

- NOTE:**
- MATERIAL SPECIFICATION:**
    - HOUSING: HIGH TEMPERATURE RESISTANT PLASTIC, UL94 V-0.
    - TERMINAL: COPPER ALLOY
    - MID PLATE: STAINLESS STEEL
    - FRONT SHELL: STAINLESS STEEL
  - PLATING SPECIFICATION:**
    - TERMINAL:**
      - Ni 50u" MIN. UNDER PLATED OVER ALL.
      - Au PLATED ON THE FUNCTIONAL AREA OF CONTACT.
      - (GOLD PLATING THICKNESS FOLLOW THE P/N)
      - PLATING SPECIFICATIONS OF THE SOLDER AREA FOLLOW THE P/N
    - FRONT SHELL:**
      - PLATING SPECIFICATIONS FOLLOW THE P/N
    - MID PLATE:**
      - CLEAR ONLY
  - MECHANICAL PERFORMANCE,**
    - INSERTION FORCE:** 0.5~2.0kgf.
    - REMOVAL FORCE:** 0.8kgf~2.0kgf.
    - DURABILITY:** 10000 CYCLES.
  - ELECTRICAL PERFORMANCE,**
    - VOLTAGE RATING:** 5 V DC/AC (RMS. max)  
CURRENT RATING: 5 AMPS. FOR TOTAL VBUS/GND PINS;  
1.25AMPS FOR CC PIN, 0.25 AMPS. FOR ALL OTHER CONTACT.
    - LLCR:**  
VBUS & GND PINS AND OTHER PINS: 40ma/PIN MAX.  
LLCR MAX. CHANGE OF ALL PINS: 10ma.
    - INSULATION RESISTANCE:** 100MΩ MIN
    - DIELECTRIC WITHSTAND VOLTAGE, AC** 100V FOR 1 MINUTE.
  - ENVIRONMENTAL PERFORMANCE:**  
OPERATING TEMPERATURE: -25°C~+85°C.
  - IR REFLOW:**  
THE PEAK TEMPERATURE ON THE BOARD SHALL BE MAINTAINED FOR 10 SECONDS AT 260°C.

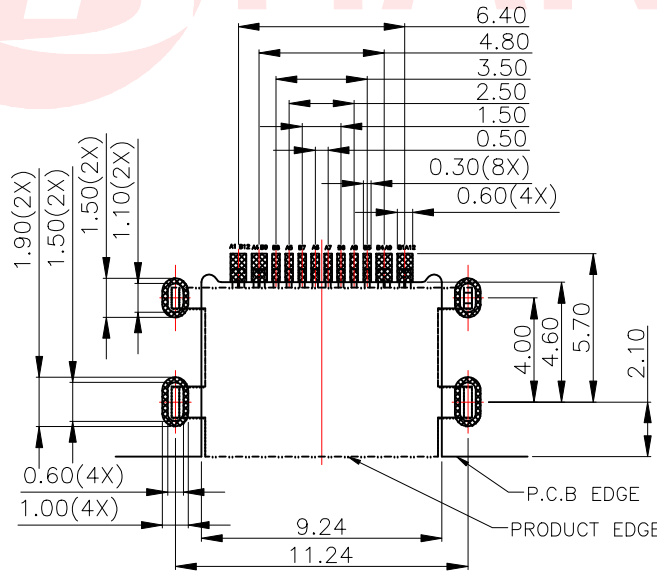
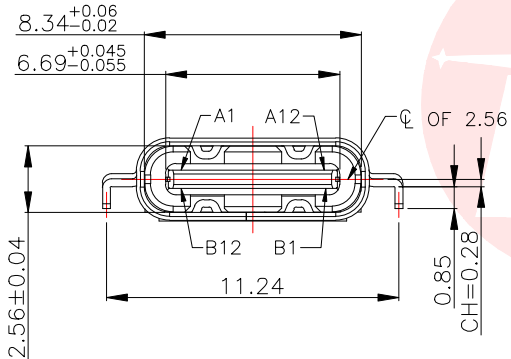

USB TYPE-C PIN ASSIGNMENTS

PIN NUMBER	SIGNAL NAME	PIN NUMBER	SIGNAL NAME
A1	GND	B12	GND
A4	VBUS	B9	VBUS
A5	CC1	B8	SBU2
A6	Dp1	B7	Dn2
A7	Dn1	B6	Dp2
A8	SBU1	B5	CC2
A9	VBUS	B4	VBUS
A12	GND	B1	GND

RECOMMENDED PCB LAYOUT(TOP VIEW)  
THICKNESS 0.80MM; DEFAULT TOLERANCE: ±0.05

UNLESS OTHERWISE SPECIFIED TOLERANCES

DECIMALS:	ANGLES:
X :±0.30	X :±2°
X.X :±0.20	X.X :±1°
X.XX :±0.10	



东莞市汉博电子科技有限公司  
DONGGUAN HANBO TECHNOLOGY CO., LTD

TITLE	USB CF 16PIN (L=6.5) MID MOUNT 1.30mm		
DWN	xiong	PART NO. MC-109-C130-EP16	
CHKD	lee	SCALE: 1:1	UNIT: mm
APVD	wang	SIZE: A4	SHEET: 10F 1
REV: A4			

CUSTOMER COPY



REV.	ECN NO OR DESCRIPTION	REVISED	DATE

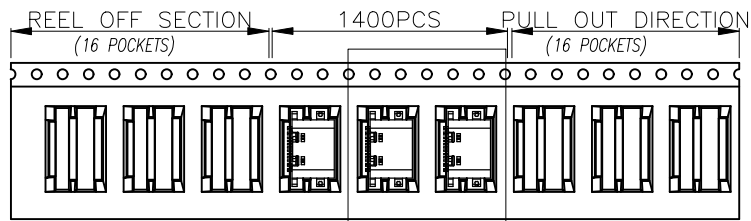

SEE DETAIL X

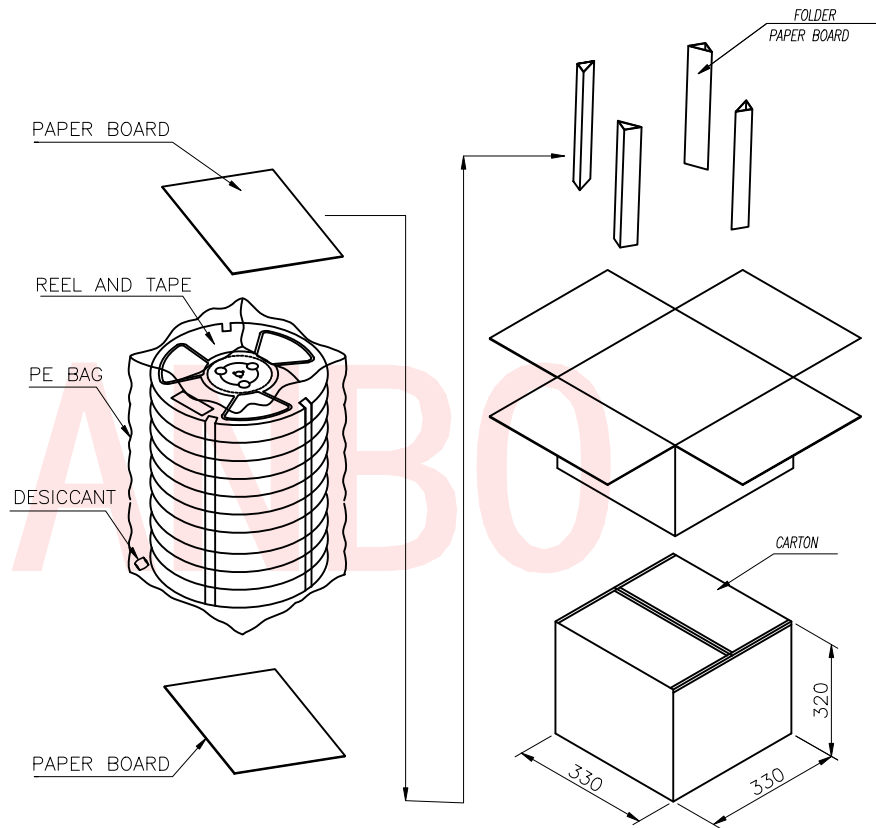
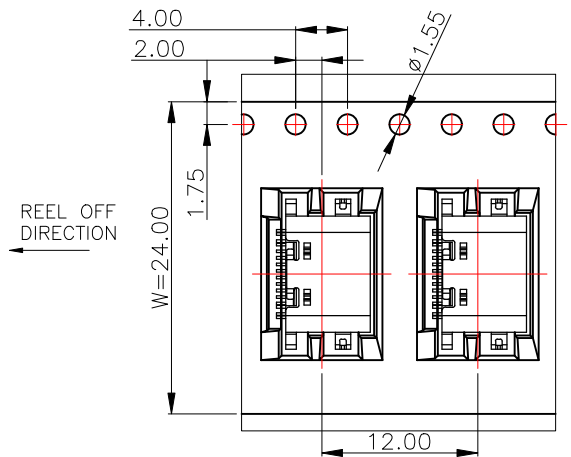
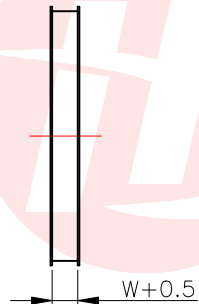
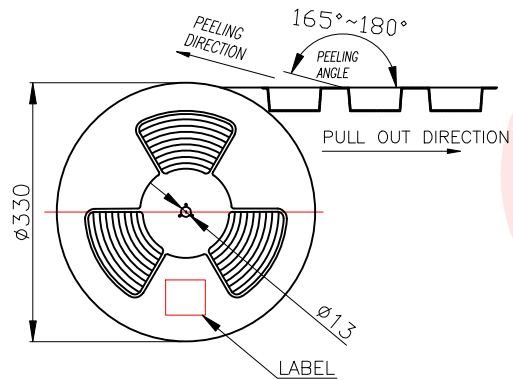

		REEL	CARTON
CONNECTOR (PCS)		1400	14000
UNLESS OTHERWISE SPECIFIED TOLERANCES		东莞市汉博电子科技有限公司 DONGGUAN HANBO TECHNOLOGY CO., LTD	
DECIMALS: X :±0.30 X.X :±0.20 X.XX :±0.10		TITLE USB CF 16PIN (L=6.5) MID MOUNT 1.30mm DWN xiong PART NO. MC-109-C130-EP16 CHKD lee SCALE:1:1 UNIT: mm APVD wang SIZE: A4 SHEET:10F 1 REV: A4	
		CUSTOMER COPY	